

ASTER User Handbook

Advanced Spaceborne Thermal Emission and Reflection Radiometer

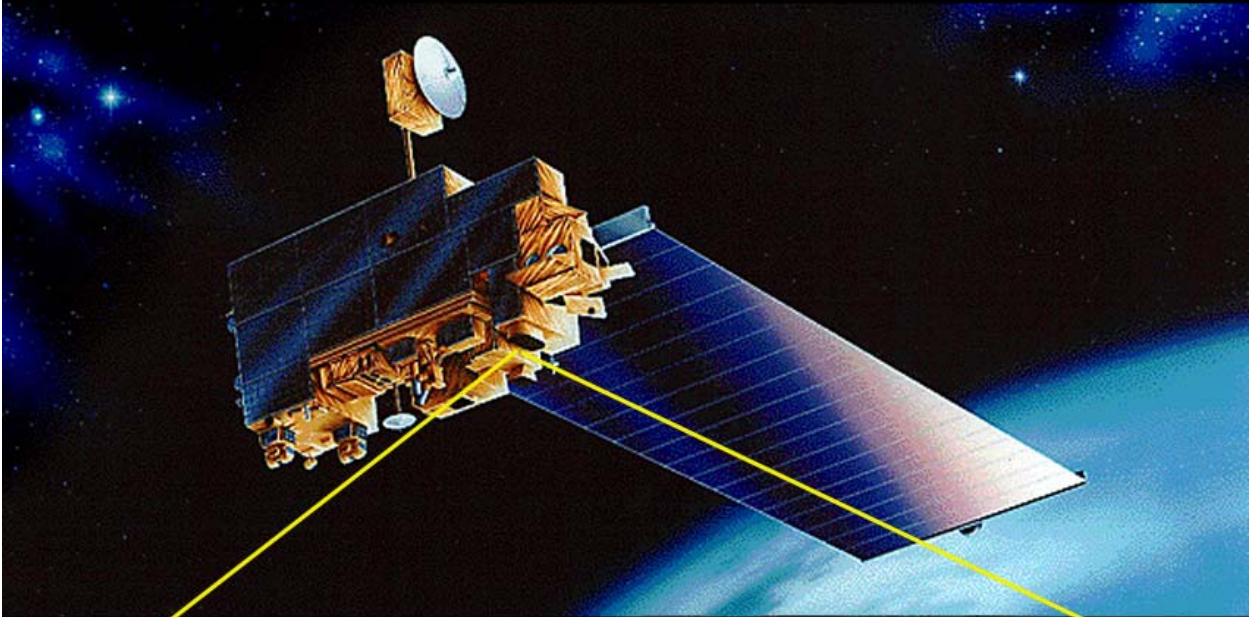

JPL

Jet Propulsion Laboratory
California Institute of Technology





ASTER User Handbook

Version 2

Michael Abrams
Simon Hook
Jet Propulsion Laboratory
4800 Oak Grove Dr.
Pasadena, CA 91109

Bhaskar Ramachandran
EROS Data Center
Sioux Falls, SD 57198



Acknowledgments

This document was prepared at the Jet Propulsion Laboratory/California Institute of Technology. Work was performed under contract to the National Aeronautics and Space Administration.



Table of Contents

1.0 Introduction to ASTER 8

2.0 The ASTER Instrument 8

 2.1 The VNIR Instrument 11

 2.2 The SWIR Instrument 12

 2.3 The TIR Instrument 13

3.0 ASTER Level-1 Data 16

 3.1 ASTER Level-1A Data 19

 3.1.1 ASTER Level-1A Browse 19

 3.2 ASTER Level-1B Data 21

 3.2.1 ASTER Level-1B Browse 21

4.0 ASTER Higher-Level Products 24

5.0 ASTER Radiometry 25

6.0 ASTER Geometry 27

7.0 Data Acquisition Strategy 29

8.0 ASTER Data Search and Order of Archived Data and Products 31

9.0 ASTER Higher-Level Data Products Ordering Mechanism 40

10.0 Data Acquisition Requests 41

11.0 ASTER Applications 41

 11.1 Cuprite, Nevada 41

 11.2 Lake Tahoe 45

 11.2.1 Objective 45

 11.2.2 Introduction 45

 11.2.3 Field Measurements 46

 11.2.4 Using ASTER to measure water clarity 48

 11.2.5 Using ASTER to Measure Circulation 52

12.0 Geo-Referencing ASTER Level-1B Data 54

 12.1 Introduction 54

 12.2 Accessing ASTER Level-1B Metadata 54

 12.3 ASTER Level-1B Geo-Referencing Methodology 56

 12.4 Unique Features of ASTER Level-1B Data 57

 12.4.1 Pixel Reference Location 57

 12.4.2 Footprint of an ASTER Level-1B Image 57

 12.4.3 Path- or Satellite-Orientation of an ASTER Level-1B Image 58

 12.4.4 Geometric Correction Table 59

 12.4.5 Geodetic versus Geocentric Coordinates 61

13.0 Frequently-Asked Questions 62

 13.1 General ASTER 62

 13.2 ASTER Instrument 63

 13.3 ASTER Level-1 Data 63

 13.4 Acquiring and Ordering ASTER Data 69

 13.5 ASTER Metadata 70

 13.6 ASTER Higher-Level Products 81

 13.7 ASTER Expedited Data Sets 83

 13.8 ASTER-Related Algorithms 84



ASTER Users Handbook

| | |
|---|-----|
| 13.9 ASTER Documentation | 85 |
| 13.10 HDF-EOS Data Format..... | 86 |
| Appendix I: Dump of HDF Metadata in a ASTER L1B file | 87 |
| Appendix II: ASTER Higher-Level Data Products | 95 |
| Appendix III: Metadata Cross Reference Table | 114 |
| Appendix IV: Public Domain Software for Handling HDF-EOS Format..... | 131 |
| Appendix V: LP-DAAC Data Sets Available through EDC via the EDG | 133 |



Table of Figures

Figure 1: The ASTER Instrument before Launch..... 9

Figure 2: Comparison of Spectral Bands between ASTER and Landsat-7 Thematic Mapper..... 10

Figure 3: VNIR Subsystem Design..... 12

Figure 4: SWIR Subsystem Design. 13

Figure 5: TIR Subsystem Design..... 15

Figure 6: End-to-End Processing Flow of ASTER data between US and Japan..... 18

Figure 9: Opening Page of the EOS Data Gateway..... 32

Figure 10: Choosing Search Keyword “DATASET.” 33

Figure 11: Choosing Search Area. 34

Figure 12: Choosing a Date/Time Range..... 35

Figure 13: Data Set Listing Result..... 36

Figure 14: Data Granules Listing Result. 37

Figure 15: Choosing Ordering Options..... 38

Figure 16: Order Form. 39

Figure 17: Cuprite Mining District, displayed with SWIR bands 4-6-8 as RGB composite..... 42

Figure 18: Spectral Angle Mapper Classification of Cuprite SWIR data..... 43

Figure 19: ASTER image spectra (left) and library spectra (right) for minerals..... 44
mapped at Cuprite. 44

Figure 20: Outline map of Lake Tahoe, CA/NV. 45

Figure 21: Raft Measurements..... 46

Figure 22: Field measurements at the US Coast Guard..... 48

Figure 23: Color Infrared Composite of ASTER bands 3, 2, 1 as R, G, B respectively. 49

Figure 24: ASTER band 1 (0.52-0.60 μm) color-coded to show variations in the intensity of the
near-shore bottom reflectance..... 50

Figure 25: Bathymetric map of Lake Tahoe CA/NV..... 51

Figure 26: Near-shore clarity map derived from ASTER data and a bathymetric map. 52

Figure 27: ASTER Band-13 Brightness Temperature Image of Lake Tahoe from Thermal Data
Acquired June 3, 2001. 53

Figure 28: Upper-left pixel of VNIR, SWIR and TIR bands in an ASTER Level-1B data set.... 57

Figure 29: ASTER L1B Footprint in the Context of the SCENEFOURCORNERS Alignment.. 58

Figure 30: Ascending and Descending Orbital Paths. 59

Figure 31: G-Ring and G-Polygon..... 78



List of Tables

| | |
|---|----|
| Table 1: Characteristics of the 3 ASTER Sensor Systems. | 10 |
| Table 2: Specifications of the ASTER Level-1A Browse Product..... | 19 |
| Table 2: Resampling Methods and Projections Available for Producing Level-1B products. | 23 |
| Table 3: ASTER Higher-Level Standard Data Products. | 24 |
| Table 4: Maximum Radiance Values for all ASTER Bands and all Gains. | 25 |
| Table 5: Calculated Unit Conversion Coefficients. | 26 |
| Table 6: Geometric Performance of ASTER Level-1 Data (Based on V2.1 of the Geometric Correction Database). | 28 |
| Table 7: Specific Metadata Attributes Required for Geo-Referencing ASTER Level-1B Data. . | 55 |



1.0 Introduction to ASTER

The Advanced Spaceborne Thermal Emission and Reflection Radiometer (ASTER) is an advanced multispectral imager that was launched on board NASA's Terra spacecraft in December, 1999. ASTER covers a wide spectral region with 14 bands from the visible to the thermal infrared with high spatial, spectral and radiometric resolution. An additional backward-looking near-infrared band provides stereo coverage. The spatial resolution varies with wavelength: 15 m in the visible and near-infrared (VNIR), 30 m in the short wave infrared (SWIR), and 90 m in the thermal infrared (TIR). Each ASTER scene covers an area of 60 x 60 km.

Terra is the first of a series of multi-instrument spacecraft forming NASA's Earth Observing System (EOS). EOS consists of a science component and a data information system (EOSDIS) supporting a coordinated series of polar-orbiting and low inclination satellites for long-term global observations of the land surface, biosphere, solid Earth, atmosphere, and oceans. By enabling improved understanding of the Earth as an integrated system, the EOS program has benefits for us all. In addition to ASTER, the other instruments on Terra are the Moderate-Resolution Imaging Spectroradiometer (MODIS), Multi-angle Imaging Spectro-Radiometer (MISR), Clouds and the Earth's Radiant Energy System (CERES), and Measurements of Pollution in the Troposphere (MOPITT). As the only high spatial resolution instrument on Terra, ASTER is the "zoom lens" for the other instruments. Terra is in a sun-synchronous orbit, 30 minutes behind Landsat ETM+; it crosses the equator at about 10:30 am local solar time.

ASTER can acquire data over the entire globe with an average duty cycle of 8% per orbit. This translates to acquisition of about 650 scenes per day, that are processed to Level-1A; of these, about 150 are processed to Level-1B. All 1A and 1B scenes are transferred to the EOSDIS archive at the EROS Data Center's (EDC) Land Processes Distributed Active Archive Center (LP-DAAC), for storage, distribution, and processing to higher-level data products. All ASTER data products are stored in a specific implementation of Hierarchical Data Format called HDF-EOS.

2.0 The ASTER Instrument

ASTER is a cooperative effort between NASA and Japan's Ministry of Economy Trade and Industry (METI) formerly known as Ministry of International Trade and Industry (MITI), with the collaboration of scientific and industry organizations in both countries. The ASTER instrument consists of three separate instrument subsystems (Figure 1).

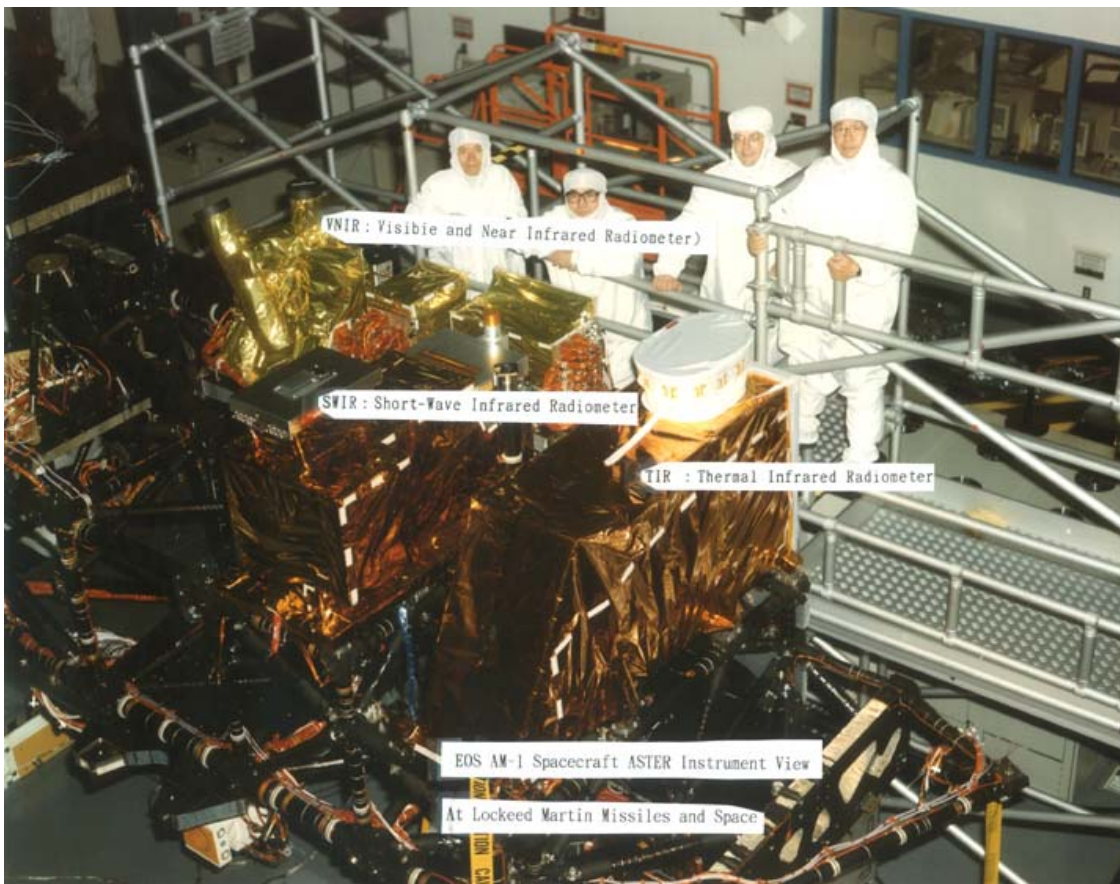

Figure 1: The ASTER Instrument before Launch.

ASTER consists of three different subsystems (Figure 2): the Visible and Near-infrared (VNIR) has three bands with a spatial resolution of 15 m, and an additional backward telescope for stereo; the Shortwave Infrared (SWIR) has 6 bands with a spatial resolution of 30 m; and the Thermal Infrared (TIR) has 5 bands with a spatial resolution of 90 m. Each subsystem operates in a different spectral region, with its own telescope(s), and is built by a different Japanese company. The spectral bandpasses are shown in Table 1, and a comparison of bandpasses with Landsat Thematic Mapper is shown in Figure 3. In addition, one more telescope is used to view backward in the near-infrared spectral band (band 3B) for stereoscopic capability.



| Subsystem | Band No. | Spectral Range (μm) | Spatial Resolution, m | Quantization Levels |
|-----------|----------|---------------------|-----------------------|---------------------|
| VNIR | 1 | 0.52-0.60 | 15 | 8 bits |
| | 2 | 0.63-0.69 | | |
| | 3N | 0.78-0.86 | | |
| | 3B | 0.78-0.86 | | |
| SWIR | 4 | 1.60-1.70 | 30 | 8 bits |
| | 5 | 2.145-2.185 | | |
| | 6 | 2.185-2.225 | | |
| | 7 | 2.235-2.285 | | |
| | 8 | 2.295-2.365 | | |
| | 9 | 2.360-2.430 | | |
| TIR | 10 | 8.125-8.475 | 90 | 12 bits |
| | 11 | 8.475-8.825 | | |
| | 12 | 8.925-9.275 | | |
| | 13 | 10.25-10.95 | | |
| | 14 | 10.95-11.65 | | |

Table 1: Characteristics of the 3 ASTER Sensor Systems.

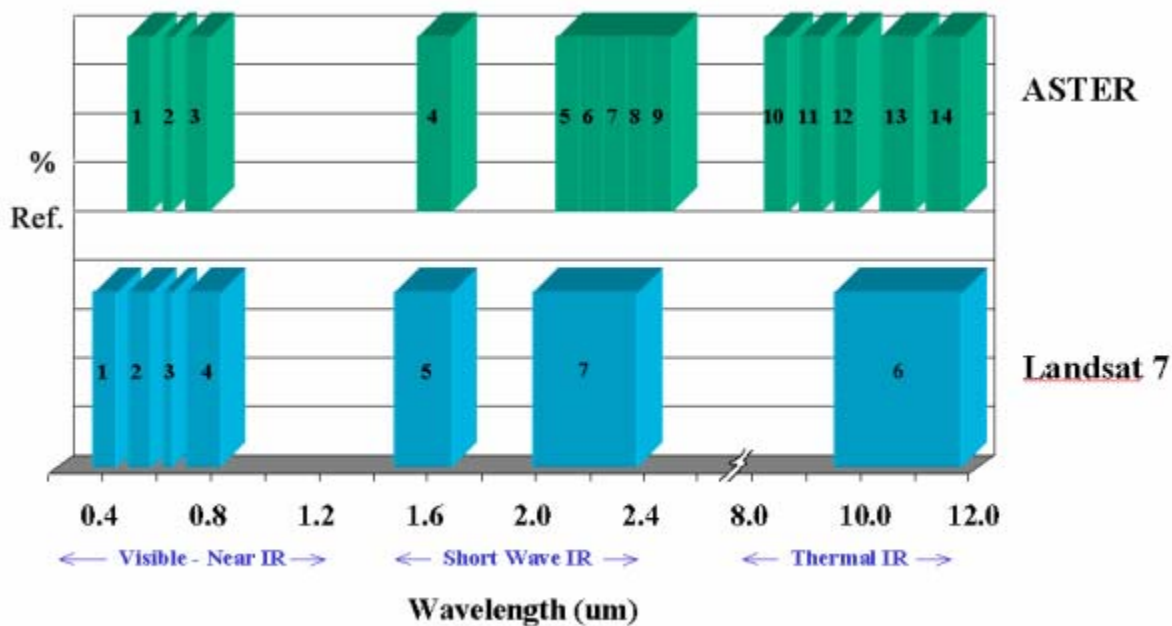

Figure 2: Comparison of Spectral Bands between ASTER and Landsat-7 Thematic Mapper.

(Note: % Ref is reflectance percent).

The Terra spacecraft is flying in a circular, near-polar orbit at an altitude of 705 km. The orbit is sun-synchronous with equatorial crossing at local time of 10:30 a.m., returning to the same orbit



every 16 days. The orbit parameters are the same as those of Landsat 7, except for the local equatorial crossing time.

2.1 The VNIR Instrument

The VNIR subsystem consists of two independent telescope assemblies to minimize image distortion in the backward and nadir looking telescopes (Figure 3). The detectors for each of the bands consist of 5000 element silicon charge-coupled detectors (CCD's). Only 4000 of these detectors are used at any one time. A time lag occurs between the acquisition of the backward image and the nadir image. During this time earth rotation displaces the image center. The VNIR subsystem automatically extracts the correct 4000 pixels based on orbit position information supplied by the EOS platform.

The VNIR optical system is a reflecting-refracting improved Schmidt design. The backward looking telescope focal plane contains only a single detector array and uses an interference filter for wavelength discrimination. The focal plane of the nadir telescope contains 3 line arrays and uses a dichroic prism and interference filters for spectral separation allowing all three bands to view the same area simultaneously. The telescope and detectors are maintained at $296 \pm 3\text{K}$ using thermal control and cooling from a platform-provided cold plate. On-board calibration of the two VNIR telescopes is accomplished with either of two independent calibration devices for each telescope. The radiation source is a halogen lamp. A diverging beam from the lamp filament is input to the first optical element (Schmidt corrector) of the telescope subsystem filling part of the aperture. The detector elements are uniformly irradiated by this beam. In each calibration device, two silicon photo-diodes are used to monitor the radiance of the lamp. One photo-diode monitors the filament directly and the second monitors the calibration beam just in front of the first optical element of the telescope. The temperatures of the lamp base and the photo-diodes are also monitored. Provision for electrical calibration of the electronic components is also provided.

The system signal-to-noise is controlled by specifying the NE delta rho (ρ) to be $< 0.5\%$ referenced to a diffuse target with a 70% albedo at the equator during equinox. The absolute radiometric accuracy is $\pm 4\%$ or better.

The VNIR subsystem produces by far the highest data rate of the three ASTER imaging subsystems. With all four bands operating (3 nadir and 1 backward) the data rate including image data, supplemental information and subsystem engineering data is 62 Mbps.

ASTER Instrument: VNIR Subsystem Design

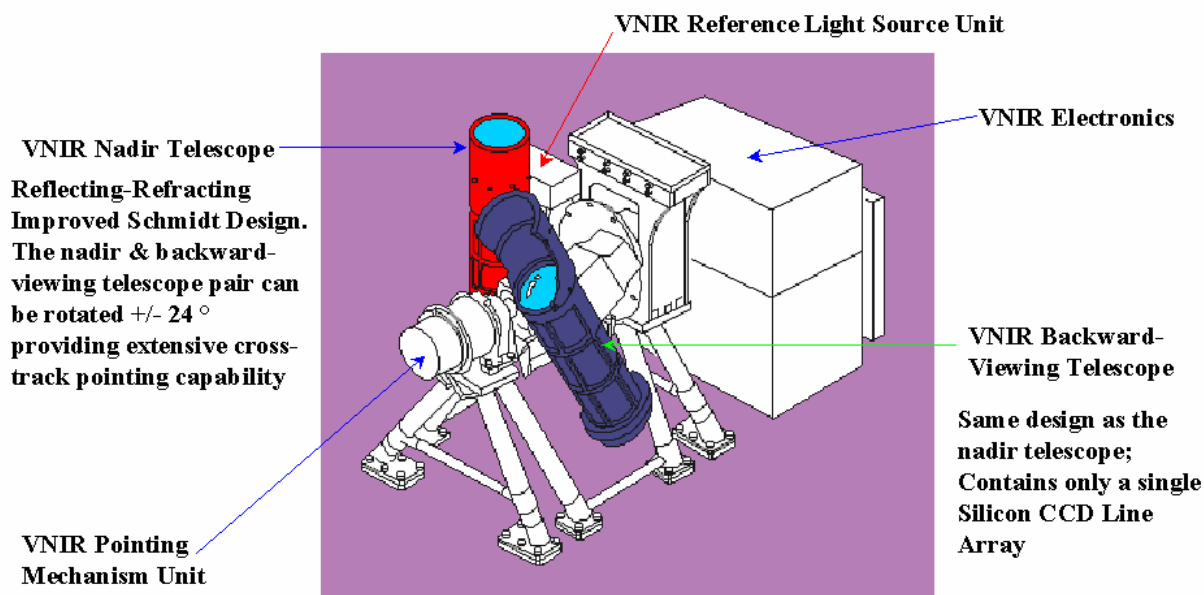

Figure 3: VNIR Subsystem Design.

2.2 The SWIR Instrument

The SWIR subsystem uses a single aspheric refracting telescope (Figure 4). The detector in each of the six bands is a Platinum Silicide-Silicon (PtSi-Si) Schottky barrier linear array cooled to 80K. A split Stirling cycle cryocooler with opposed compressors and an active balancer to compensate for the expander displacer provide cooling. The on-orbit design life of this cooler is 50,000 hours. Although ASTER operates with a low duty cycle (8% average data collection time), the cryocooler operates continuously because the cool-down and stabilization time is long. No cryocooler has yet demonstrated this length of performance, and the development of this long-life cooler was one of several major technical challenges faced by the ASTER team. The cryocooler is a major source of heat. Because the cooler is attached to the SWIR telescope, which must be free to move to provide cross-track pointing, this heat cannot be removed using a platform provided cold plate. This heat is transferred to a local radiator attached to the cooler compressor and radiated into space.

Six optical bandpass filters are used to provide spectral separation. No prisms or dichroic elements are used for this purpose. A calibration device similar to that used for the VNIR subsystem is used for in-flight calibration. The exception is that the SWIR subsystem has only one such device.

The NE delta rho will vary from 0.5 to 1.3% across the bands from short to long wavelength. The absolute radiometric accuracy is +4% or better. The combined data rate for all six SWIR bands, including supplementary telemetry and engineering telemetry, is 23 Mbps.

ASTER Instrument: SWIR Subsystem Design

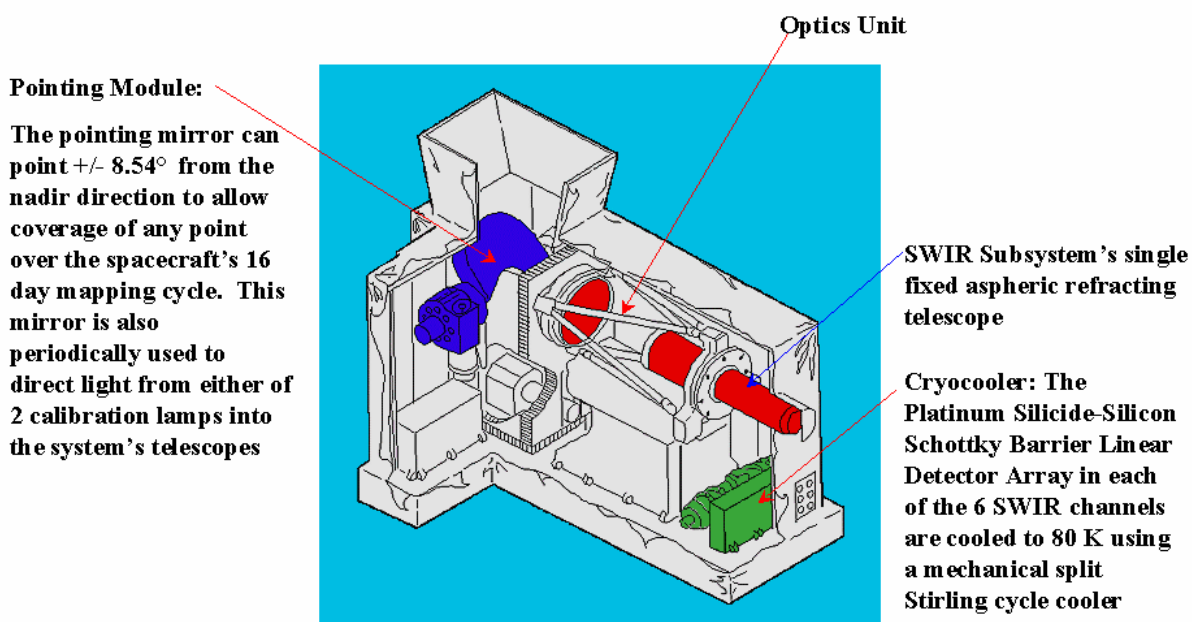

Figure 4: SWIR Subsystem Design.

2.3 The TIR Instrument

The TIR subsystem uses a Newtonian catadioptric system with an aspheric primary mirror and lenses for aberration correction (Figure 5). Unlike the VNIR and SWIR telescopes, the telescope of the TIR subsystem is fixed with pointing and scanning done by a mirror. Each band uses 10 Mercury-Cadmium-Telluride (HgCdTe) detectors in a staggered array with optical band-pass filters over each detector element. Each detector has its own pre- and post-amplifier for a total of 50.

As with the SWIR subsystem, the TIR subsystem uses a mechanical split Stirling cycle cooler for maintaining the detectors at 80K. In this case, since the cooler is fixed, the waste heat it generates is removed using a platform supplied cold plate.



The scanning mirror functions both for scanning and pointing. In the scanning mode the mirror oscillates at about 7 Hz. For calibration, the scanning mirror rotates 180 degrees from the nadir position to view an internal black body which can be heated or cooled. The scanning/pointing mirror design precludes a view of cold space, so at any one time only a single point temperature calibration can be effected. The system does contain a temperature controlled and monitored chopper to remove low frequency drift. In flight, a single point calibration can be done frequently (e.g., every observation) if necessary. On a less frequent interval, the black body may be cooled or heated (to a maximum temperature of 340K) to provide a multipoint thermal calibration. Facility for electrical calibration of the post-amplifiers is also provided.

For the TIR subsystem, the signal-to-noise can be expressed in terms of an NE delta T. The requirement is that the NE delta T be less than 0.3K for all bands with a design goal of less than 0.2K. The signal reference for NE delta T is a blackbody emitter at 300K. The accuracy requirements on the TIR subsystem are given for each of several brightness temperature ranges as follows: 200 - 240K, 3K; 240 - 270K, 2K; 270 - 340K, 1K; and 340 - 370K, 2K.

The total data rate for the TIR subsystem, including supplementary telemetry and engineering telemetry, is 4.2 Mbps. Because the TIR subsystem can return useful data both day and night, the duty cycle for this subsystem is set at 16%. The cryocooler, like that of the SWIR subsystem, operates with a 100% duty cycle.

ASTER Instrument: TIR Subsystem Design

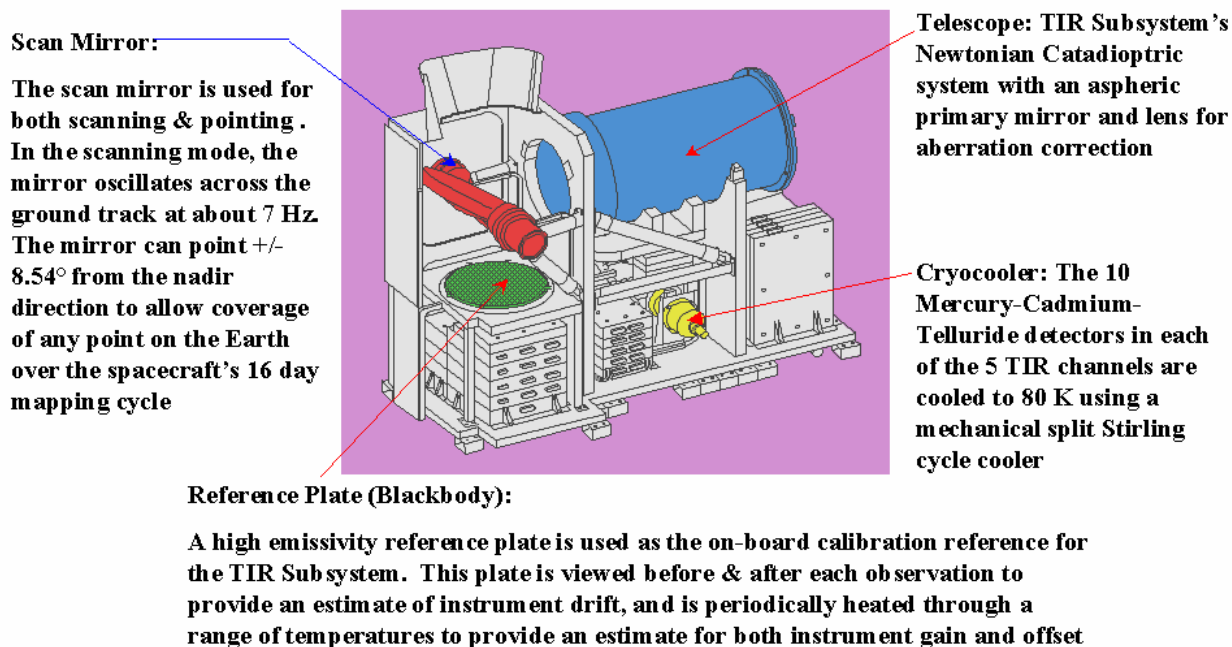

Figure 5: TIR Subsystem Design.

3.0 ASTER Level-1 Data

The ASTER instrument produces two types of Level-1 data: Level-1A (L1A) and Level-1B (L1B). ASTER L1A data are formally defined as reconstructed, unprocessed instrument data at full resolution. They consist of the image data, the radiometric coefficients, the geometric coefficients and other auxiliary data without applying the coefficients to the image data, thus maintaining original data values. The L1B data are generated by applying these coefficients for radiometric calibration and geometric resampling.

All acquired image data are processed to L1A. On-board storage limitations on the spacecraft limit ASTER's acquisition to about 650 L1A scenes per day. A maximum of 310 scenes per day are processed to L1B based on cloud coverage. The end-to-end flow of data, from upload of daily acquisition schedules to archiving at the LP-DAAC, is shown in Figure 6. The major steps involved in the processing of Level-1 data can be summarized thus:

- The one-day acquisition schedule is generated in Japan at ASTER GDS with inputs from both US and Japan, and is sent to the EOS Operations Center (EOC) at the Goddard Spaceflight Center (GSFC).
- The one-day acquisition schedule is uplinked to Terra, and data are accordingly acquired.
- Terra transmits the Level-0 data via the Tracking and Data Relay Satellite System (TDRSS), to ground receiving stations at White Sands, New Mexico in the US.
- These data are shipped on tape to the EOS Data Operations System (EDOS) at GSFC.
- EDOS, following some minimal pre-processing, ships the data on tapes (by air) to ASTER GDS in Tokyo, Japan
- GDS processes Level-0 to Level-0A in the Front-End Processing Module which includes:
 - **Depacketizing Level-0 Data:** a depacketizing function to recover the instrument source data. The packets for each group are depacketized and aligned to recover the instrument source data using a sequential counter, flags in the primary header, and time tags in the secondary header. The spectral band information in the instrument source data is multiplexed with the image in Band Interleaved by Pixel (BIP) format.
 - **Demultiplexing Instrument Source Data:** a demultiplexing function to separate image data into spectral bands in BSQ format. The instrument source data are demultiplexed to separate image data for every spectral band in BSQ format. Each (Level-0A) data group (VNIR, SWIR, & TIR) contains image data, instrument supplementary data, & spacecraft ancillary data.
 - **SWIR and TIR Image Data Stagger Realignment:** SWIR and TIR image data are re-aligned to compensate for a staggered configuration. The SWIR parallax error is caused by the offset in the detector alignment in the along-track direction. The parallax correction is done with a combination of image matching correlation and DEM methods.
 - **Geometric system correction:** Coordinate transformation of the line of sight vector using the ancillary information from the instrument supplementary data and spacecraft ancillary data to identify the observation points in latitude/longitude coordinates on the Earth's surface defined by the WGS84 Earth model.



- Radiometric coefficients are generated using real temperature values in the instrument supplementary data.
- ASTER GDS ships the final ASTER L1A and L1B data on tapes (by air) to the LP-DAAC for archiving, distribution, and processing to higher level data products.

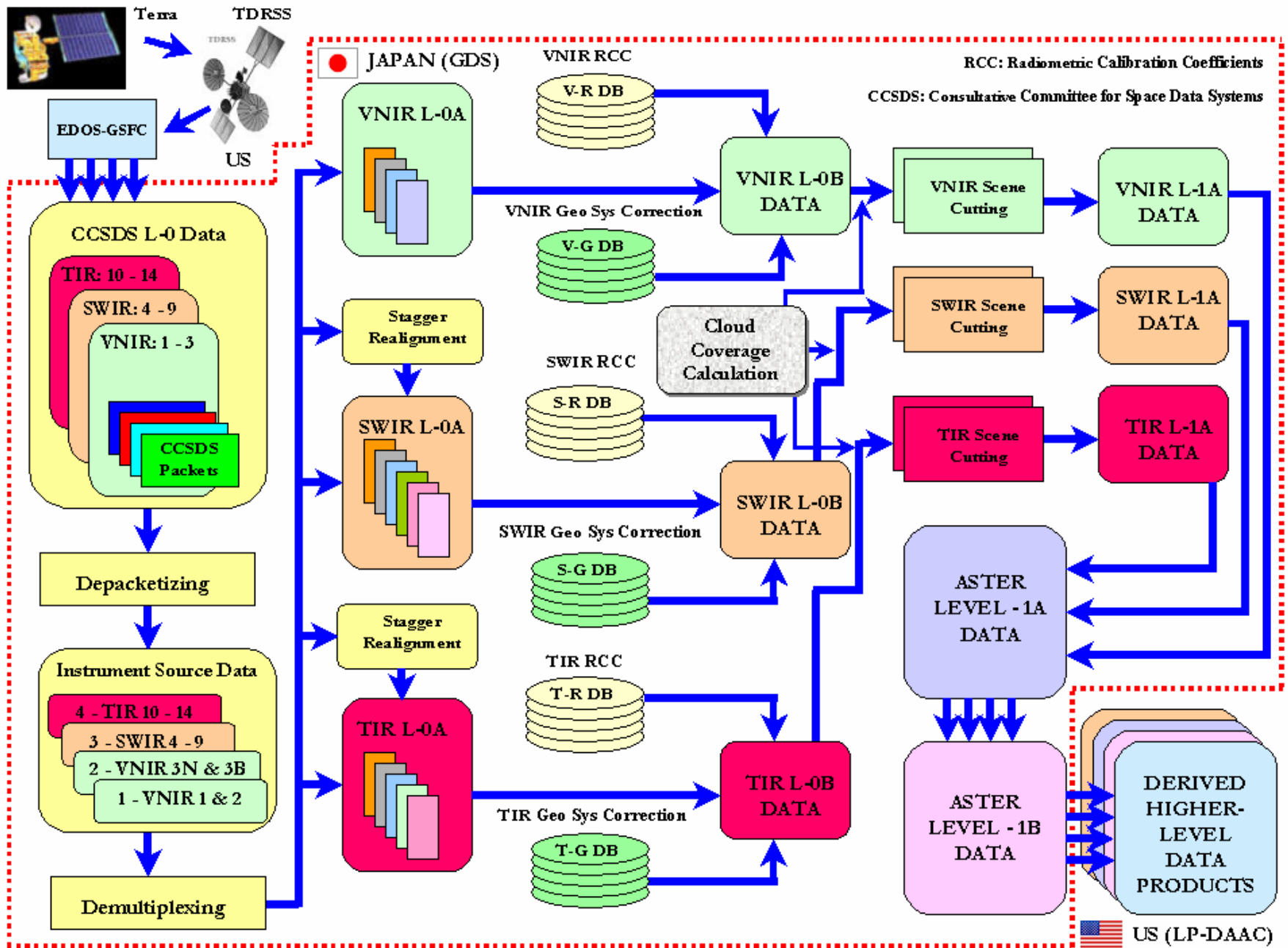

Figure 6: End-to-End Processing Flow of ASTER data between US and Japan.



3.1 ASTER Level-1A Data

The ASTER Level-1A raw data are reconstructed from Level-0, and are unprocessed instrument digital counts. This product contains depacketized, demultiplexed and realigned instrument image data with geometric correction coefficients and radiometric calibration coefficients appended but not applied. These coefficients include correcting for SWIR parallax as well as inter- and intra-telescope registration. (The SWIR parallax error is caused by the offset in detector alignment in the along-track direction and depends on the distance between the spacecraft and the observed earth surface. For SWIR bands the parallax corrections are carried out with the image matching technique or the coarse DEM data base, depending on cloud cover). The spacecraft ancillary and instrument engineering data are also included. The radiometric calibration coefficients, consisting of offset and sensitivity information, are generated from a database for all detectors, and are updated periodically. The geometric correction is the coordinate transformation for band-to-band co-registration. The VNIR and SWIR data are 8-bit and have variable gain settings. The TIR data are 12-bit with a single gain. The structure of the data inside a Level-1A product is illustrated in Figure 7. This is in HDF-EOS format.

3.1.1 ASTER Level-1A Browse

The ASTER Level-1A also contains browse images for each of the three sensors. The browse product contains 1-scene of image data generated based on the Level-1A data with similar radiometric corrections and mis-registration corrections applied to Level-1B data. All image data (VNIR, SWIR, TIR) are 24-bit JPEG compressed images stored in an HDF file in RIS24 objects. The following table (Table 2) provides the main characteristics of the Level-1A browse images:

| Telescope | Dimensions (pixel x line) | Compression Method | Quality Factor | Blue | Green | Red |
|-----------|------------------------------|-----------------------|-------------------|---------|---------|---------|
| VNIR | 224x208 | JPEG | 50 | Band 1 | Band 2 | Band 3N |
| SWIR | 224x208 | JPEG | 50 | Band 4 | Band 5 | Band 9 |
| TIR | 224x208 | JPEG | 50 | Band 10 | Band 12 | Band 14 |

Table 2: Specifications of the ASTER Level-1A Browse Product.

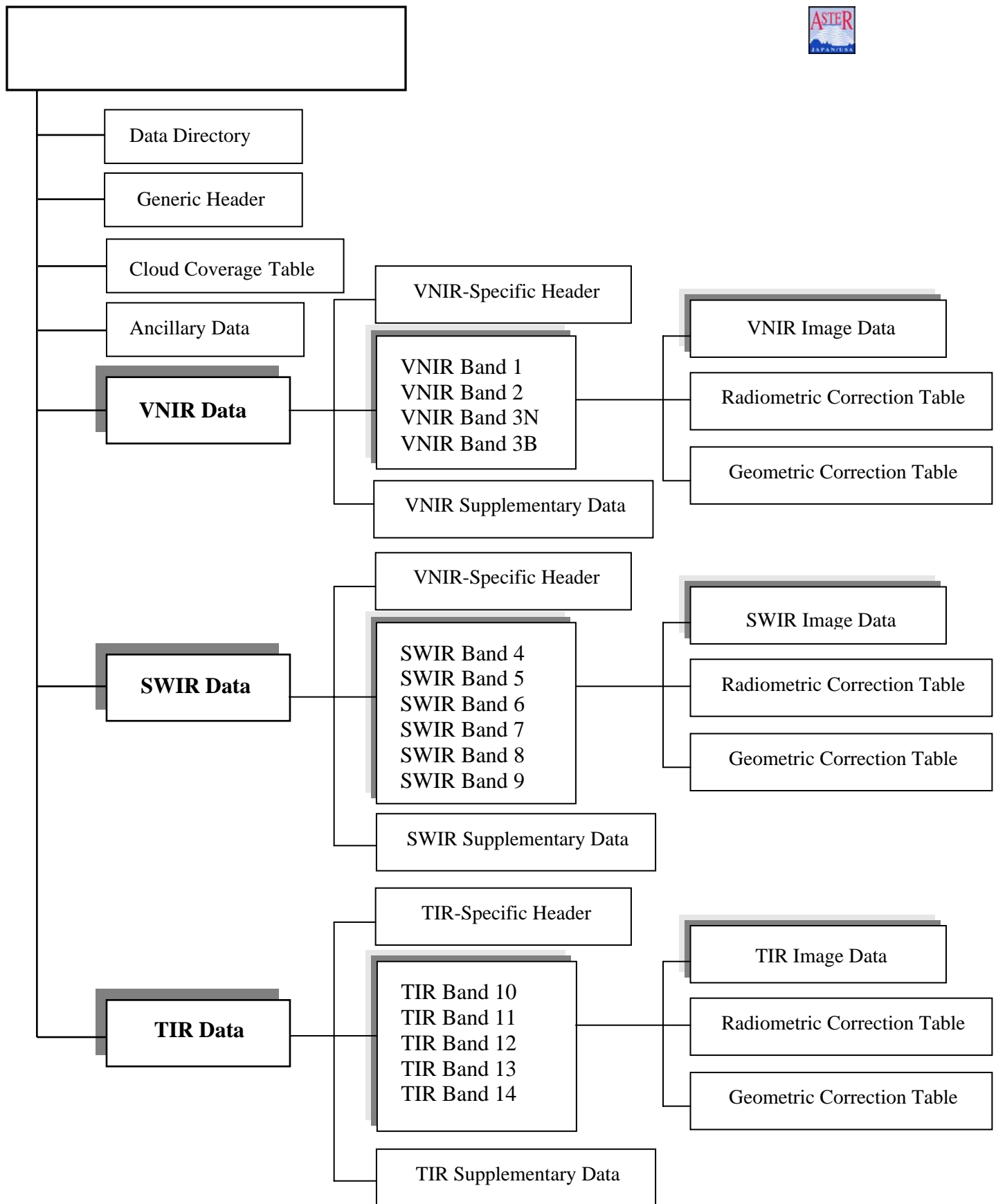

Figure 7: Data Structure of an ASTER Level-1A Data Granule.



3.2 ASTER Level-1B Data

The ASTER Level-1B data are L1A data with the radiometric and geometric coefficients applied. All of these data are stored together with metadata in one HDF file. The L1B image is projected onto a rotated map (rotated to “path oriented” coordinate) at full instrument resolutions. The Level-1B data generation also includes registration of the SWIR and TIR data to the VNIR data. And in addition, for SWIR in particular, the parallax errors due to the spatial locations of all of its bands are corrected. Level-1B data define a scene center as the geodetic center of the scene obtained from the L1A attribute named “SceneCenter” in the HDF-EOS attribute “productmetadata.0”. The definition of scene center in L1B is the actual center on the rotated coordinates (L1B coordinates) not the same as in L1A.

The structure of the L1B data file is shown schematically in Figure 8. This illustration is for the product generated when the instrument is operated in full mode (all systems are on and acquiring data). In other restricted modes, e.g. just SWIR and TIR, not all the items listed in Figure 8 are included in the product.

3.2.1 ASTER Level-1B Browse

The ASTER Level-1B data sets do not have dedicated browse images of their own. Their browse link maps back to their ASTER Level-1A parent’s browse images. Occasionally, there are instances when an L1B browse link is grayed out or inactive. This happens under two circumstances: one, the L1B data set was sent from GDS to LP-DAAC ahead of the L1A parent, or two, the LP-DAAC archive has not yet received the corresponding L1A parents.

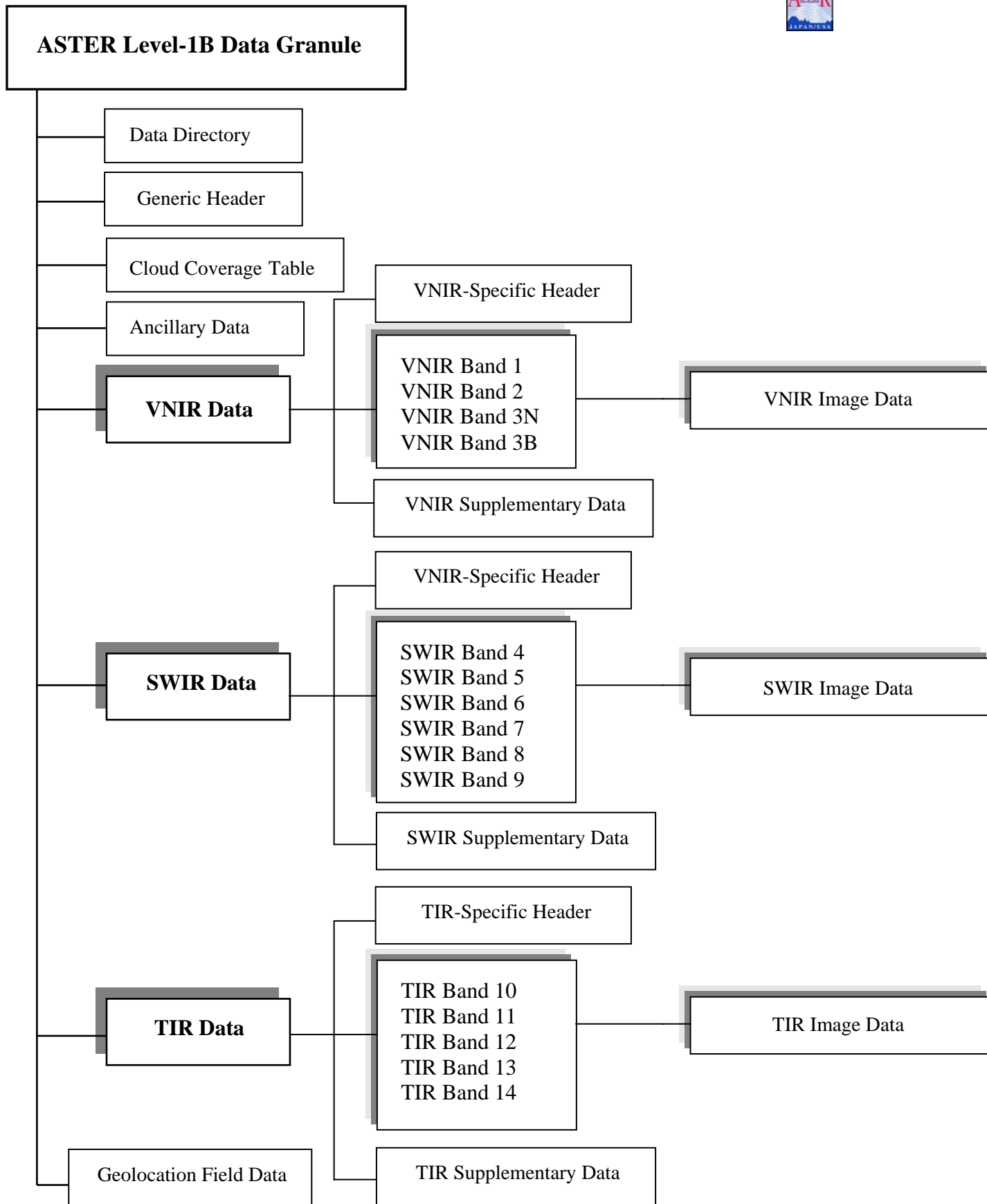

Figure 8: Data Structure of an ASTER Level-1B Data Granule.



The L1B data product is generated, by default, in UTM projection in swath orientation, and Cubic Convolution resampling. An L1B in a different projection and/or resampling method can be produced on request from GDS in Japan (Table 2).

Table 2: Resampling Methods and Projections Available for Producing Level-1B products.

| Resampling methods | Map Projections |
|------------------------|-------------------------------------|
| Nearest Neighbor (NN) | Geographic (EQRECT) |
| Cubic Convolution (CC) | Lambert Conformal Conic (LAMCC) |
| Bi-Linear (BL) | Space Oblique Mercator (SOM) |
| | Polar Stereographic (PS) |
| | Universal Transverse Mercator (UTM) |

Each image contains geolocation information stored as a series of arrays. There is one set of geolocation information (array) per nadir telescope (3 sets total). Each geolocation array is 11 x 11 elements size, with the top left element (0,0) in the image for the nadir views. For the backward view the image is offset with respect to the geolocation array. The nadir VNIR and backward-viewing VNIR images use the same latitude/longitude array, except the backward-viewing image is offset with respect to the nadir image.

The L1B latitude and longitude geolocation arrays are two 11 x 11 matrices of geocentric latitude and geodetic longitude in units of degrees. The block size of the geolocation array is 420 lines by 498 samples for the VNIR bands; 210 lines by 249 samples for the SWIR bands; and 70 lines by 83 samples for the TIR bands.

Appendix I provides a dump of the metadata contained in a L1B data product. There are five metadata groups:

- Productmetadata.0
- Productmetadata.1
- Productmetadata.V
- Productmetadata.S
- Productmetadata.T
-



4.0 ASTER Higher-Level Products

Table 3 lists each of the ASTER higher-level Standard Data Products and some of their basic characteristics. More detailed descriptions of these data products are given in Appendix II.

| Short Name | Level | Parameter Name | Production Mode | Units | Absolute Accuracy | Relative Accuracy | Horizontal Resolution (m) |
|------------|-------|--|-----------------|-----------------------------|-------------------|-------------------|---------------------------|
| AST_06V | 2 | Decorrelation stretch -VNIR | routine | none | N/A | N/A | 15 |
| AST_06S | 2 | Decorrelation stretch -SWIR | routine | none | N/A | N/A | 30 |
| AST_06T | 2 | Decorrelation stretch -TIR | routine | none | N/A | N/A | 90 |
| AST_04 | 2 | Brightness temperature | on-demand | degrees C | 1-2 C | 0.3 C | 90 |
| AST_07 | 2 | Surface reflectance VNIR,SWIR | on-demand | none | 4% | 1% | 15, 30 |
| AST_09 | 2 | Surface radiance -VNIR, SWIR | on-demand | W/m ² /sr/ μm | 2% | 1% | 15, 30 |
| AST_09T | 2 | Surface radiance -TIR | on-demand | W/m ² /sr/ μm | 2% | 1% | 90 |
| AST_05 | 2 | Surface emissivity | on-demand | none | 0.05-0.1 | 0.005 | 90 |
| AST_08 | 2 | Surface kinetic temperature | on-demand | degrees K | 1-4 K | 0.3 K | 90 |
| AST13POL | 2 | Polar surface and cloud classification | on-demand | none | 3% | 3% | 15, 30, 90 |
| AST14DEM | 3 | Digital elevation model (DEM) | on-demand | m | >= 7 m | >= 10 m | 30 |

Table 3: ASTER Higher-Level Standard Data Products.



5.0 ASTER Radiometry

The ASTER Level-1B data are offered in terms of scaled radiance. To convert from DN to radiance at the sensor, the unit conversion coefficients (defined as radiance per 1 DN) are used. Radiance (spectral radiance) is expressed in unit of $W/(m^2 \cdot sr \cdot \mu m)$. The relation between DN values and radiances is shown below:

- (i) a DN value of zero is allocated to dummy pixels
- (ii) a DN value of 1 is allocated to zero radiance
- (iii) a DN value of 254 is allocated to the maximum radiance for VNIR and SWIR bands
- (iv) a DN value of 4094 is allocated to the maximum radiance for TIR bands
- (v) a DN value of 255 is allocated to saturated pixels for VNIR and SWIR bands
- (vi) a DN value of 4095 is allocated to saturated pixels for TIR bands

The maximum radiances depend on both the spectral bands and the gain settings and are shown in Table 4.

| Band No. | Maximum radiance ($W/(m^2 \cdot sr \cdot \mu m)$) | | | |
|----------|---|-------------|------------|------------|
| | High gain | Normal Gain | Low Gain 1 | Low gain 2 |
| 1 | 170.8 | 427 | 569 | N/A |
| 2 | 179.0 | 358 | 477 | |
| 3N | 106.8 | 218 | 290 | |
| 3B | 106.8 | 218 | 290 | |
| 4 | 27.5 | 55.0 | 73.3 | 73.3 |
| 5 | 8.8 | 17.6 | 23.4 | 103.5 |
| 6 | 7.9 | 15.8 | 21.0 | 98.7 |
| 7 | 7.55 | 15.1 | 20.1 | 83.8 |
| 8 | 5.27 | 10.55 | 14.06 | 62.0 |
| 9 | 4.02 | 8.04 | 10.72 | 67.0 |
| 10 | N/A | 28.17 | N/A | N/A |
| 11 | | 27.75 | | |
| 12 | | 26.97 | | |
| 13 | | 23.30 | | |
| 14 | | 21.38 | | |

Table 4: Maximum Radiance Values for all ASTER Bands and all Gains.

The radiance can be obtained from DN values as follows:

$$\text{Radiance} = (\text{DN value} - 1) \times \text{Unit conversion coefficient}$$

Table 5 shows the unit conversion coefficients of each band



| Band No. | Coefficient (W/(m ² *sr*μm)/DN) | | | |
|----------|--|--------------------------|------------|------------|
| | High gain | Normal Gain | Low Gain 1 | Low gain 2 |
| 1 | 0.676 | 1.688 | 2.25 | N/A |
| 2 | 0.708 | 1.415 | 1.89 | |
| 3N | 0.423 | 0.862 | 1.15 | |
| 3B | 0.423 | 0.862 | 1.15 | |
| 4 | 0.1087 | 0.2174 | 0.290 | 0.290 |
| 5 | 0.0348 | 0.0696 | 0.0925 | 0.409 |
| 6 | 0.0313 | 0.0625 | 0.0830 | 0.390 |
| 7 | 0.0299 | 0.0597 | 0.0795 | 0.332 |
| 8 | 0.0209 | 0.0417 | 0.0556 | 0.245 |
| 9 | 0.0159 | 0.0318 | 0.0424 | 0.265 |
| 10 | N/A | 6.822 x 10 ⁻³ | N/A | N/A |
| 11 | | 6.780 x 10 ⁻³ | | |
| 12 | | 6.590 x 10 ⁻³ | | |
| 13 | | 5.693 x 10 ⁻³ | | |
| 14 | | 5.225 x 10 ⁻³ | | |

Table 5: Calculated Unit Conversion Coefficients.

(Note: These values are given in the telescope-specific metadata – see Appendix I)



6.0 ASTER Geometry

ASTER's geometric system correction primarily involves the rotation and the coordinate transformation of the line of sight vectors of the detectors to the coordinate system of the Earth. This is done as part of ASTER Level-1 processing at GDS using engineering data from the instrument (called supplementary data) and similar data from the spacecraft platform (called ancillary data). The geometric correction of ASTER data has evolved through elaborate processes of both pre-flight and post-launch calibration.

Pre-Flight Calibration

This is an off-line process to generate geometric parameters such as Line of Sight (LOS) vectors of the detectors and pointing axes information evaluated toward the Navigation Base Reference (NBR) of the spacecraft deemed to reflect on the instrument accuracy & stability. These data are stored in the geometric system correction database.

Post-Launch Calibration

Following launch of ASTER, these parameters are being corrected through validation using Ground Control Points (GCPs) and inter-band image matching techniques. Geometric system correction in the post-launch phase entails the following processes:

- Pointing correction
- Coordinate transformation from spacecraft coordinates to the orbital coordinates
- Coordinate transformation from orbital coordinates to the earth's inertial coordinates
- Coordinate transformation from earth's inertial coordinates to Greenwich coordinates
- Improving Band-to-Band registration accuracy through image-matching involves 2 processes:
 - SWIR parallax correction
 - Inter-telescope registration process

Based on current knowledge, the geometric performance parameters of ASTER are summarized in Table 6.



| Parameter | | Version 2.1 Geometric Db |
|------------------------------|------------|--------------------------|
| Intra-Telescope Registration | VNIR | < 0.1 pixel |
| | SWIR | < 0.1 pixel |
| | TIR | < 0.1 pixel |
| Inter-Telescope Registration | SWIR/VNIR | < 0.2 pixel |
| | TIR/VNIR | < 0.2 pixel |
| Stereo Pair System Error | Band 3B/3N | < 10 m |
| Pixel Geolocation Knowledge* | Relative | < 15 m |
| | Absolute | < 50 m |

* Not Terrain-Corrected

Table 6: Geometric Performance of ASTER Level-1 Data (Based on V2.1 of the Geometric Correction Database).

Geometric System Correction Database

There is an evolving geometric system correction database that is maintained at GDS. This database provides the geometric correction coefficients that are applied to produce the Level-1B data. The geometric correction reference in an ASTER Level-1 data set is provided in both the HDF and ECS metadata. In the HDF file, this is present as the GeometricDBVersion value in the ProductMetadata.0 block. In the ECS .met file, the same attribute name and value are present as part of the granule-level metadata. The evolving versions of the GeometricDBVersions till date have been 01.00, 01.01, 01.02, 02.00 and 02.05.



7.0 Data Acquisition Strategy

ASTER was not designed to continuously acquire data, and hence each day's data acquisitions must be scheduled and prioritized. The ASTER Science Team has developed a data acquisition strategy to make use of the available resources. Acquisition requests are divided into three categories: local observations, regional monitoring, and global map.

Local Observations

Local Observations are made in response to data acquisition requests from authorized ASTER Users. Local Observations might include, for example, scenes for analyzing land use, surface energy balance, or local geologic features.

One subset of Local Observations consists of images of such ephemeral events as volcanoes, floods, or fires. Requests for "urgent observations" of such phenomena must be fulfilled in short time periods (of a few days). These requests receive special handling.

Regional Monitoring Data

Regional data sets contain the data necessary for analysis of a large region (often many regions scattered around the Earth) or a region requiring multi-temporal analysis. A "Local Observation" data set and a "Regional Monitoring" data set are distinguished by the amount of viewing resources required to satisfy the request, where smaller requirements are defined as Local Observations and larger requirements are defined as Regional Monitoring. The ASTER Science Team has already selected a number of Regional Monitoring tasks. Among the most significant are three that involve repetitive imaging of a class of surface targets:

1. The world's mountain glaciers,
2. The world's active and dormant volcanoes, and
3. The Long-Term Ecological Research (LTER) field sites.

Global Map

The Global data set will be used by investigators of every discipline to support their research. The high spatial resolution of the ASTER Global Map will complement lower resolution data acquired more frequently by other EOS instruments. This data set will include images of the entire Earth's land surface, in all ASTER spectral bands and stereo.

Each region of the Earth has been prioritized by the ASTER Science Team for observation as part of the Global Map. Currently the following characteristics have been identified for images in the Global Map data set:



- One-time coverage
- High sun angle
- Optimum gain for the local land surface
- Minimum snow and ice cover
- Minimum vegetation cover, and
- No more than 20% cloud cover (perhaps more for special sub-regions).

Allocation of Science Data

At the present time, it is expected that approximately 25% of ASTER resources will be allocated to Local Observations, 50% to Regional Monitoring, and 25% to the Global Map.

Global Map data has been further sub-divided among high priority areas which are currently allocated 25%, medium priority areas which are currently allocated 50%, and low priority areas which are currently allocated 25%.

Regional Monitoring data sets and the Global Map will be acquired by ASTER in response to acquisition requests submitted by the ASTER Science Team acting on behalf of the science community. These Science Team Acquisition Requests (STARs) are submitted directly to the ASTER Ground Data System in Japan. Under limited circumstances, STARs for Local Observations may also be submitted by the Science Team.

STARs for Regional Monitoring data are submitted by the ASTER Science Team only after a proposal for the Regional Monitoring task has been submitted and accepted. These "STAR Proposals" will be evaluated by ASTER's science working groups before being formally submitted to the Science Team.

An already-authorized ASTER User, who wants ASTER to acquire far more data than he or she is allocated, may submit a STAR Proposal to the Science Team. Please note that the process for evaluating STAR proposals is cumbersome and time-consuming. Far fewer STAR Proposals will be approved than ASTER User Authorization Proposals.



8.0 ASTER Data Search and Order of Archived Data and Products

The EOSDIS at the LP-DAAC archives and distributes ASTER Level-1A, Level-1B, Decorrelation Stretch and DEM products. All other products are produced on demand. The steps to access the EOS Data Gateway (EDG) web site for archived products, and a tutorial on how to use it are described below. See the following sections for higher level, on-demand products. There is also another on-line tutorial that is available on the EOS Data Gateway for beginning users: <http://edcdaac.usgs.gov/tutorial/>

1: Begin Search and Order Session

Log on to the EOS Data Gateway to begin your search and order session.
(<http://edcimswww.cr.usgs.gov/pub/imswelcome/>)

New users may click the 'Enter as guest' link (Figure 9). If you are a registered user, you may continue to use your account by clicking the 'Enter as a registered user' link and login as before. Should you wish to register, click the 'Become a registered user' link and follow the registration prompts. This will take you to the 'Primary Data Search' screen. Registering will allow the system to remember your shipping information. It is absolutely not necessary to register in order to search and order.



Figure 9: Opening Page of the EOS Data Gateway.

2: Primary Data Search - Choose Search Keywords

Highlight 'DATA SET' in the 'Method 2:' scroll window and click the 'SELECT ->' button (Figure 10). This will take you to the 'Keyword Selection: Data Set' screen.

A list of data sets available are displayed in the 'Data Set list 1' scroll window.

Highlight the data set or sets you wish to search and click 'OK!'.



Figure 10: Choosing Search Keyword “DATASET.”

There are two ASTER level-1 collections available from the LP-DAAC. Therefore, you should select “ASTER L1A reconstructed unprocessed instrument data V002 & V003”; and “ASTER L1B registered radiance at the sensor V002 & V003”. The other choice of expedited data are scenes that were processed in expedited mode. These are temporarily stored for only 30 days in the archive, and are subsequently replaced by the standard processed product that arrives from GDS, Japan.



3: Primary Data Search - Choose Search Area

The next step involves delineating your area-of-interest (Figure 11). The default method to define your area of search is the 'Type in Lat/Lon Range' method. If you know the Latitude and Longitude, enter the coordinates.

To define the geographic area on a map, click the radio button next to your map of choice and delineate the region by clicking on the map.

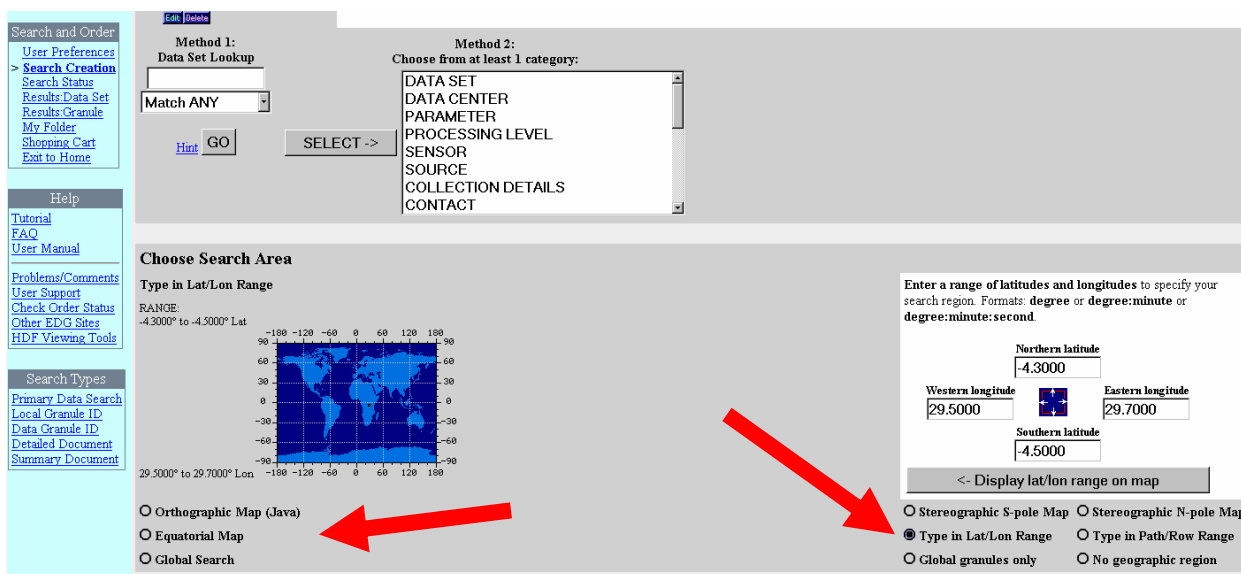

Figure 11: Choosing Search Area.

4: (optional): Primary Data Search - Choose a Time Range (not required)

You may now enter your Date or Time Range. You may use either a Standard Date Range or Julian Date Range (Figure 12).

Be sure to enter the date and time by following the format provided.

To search seasonally, select the radio button next to 'Annually Repeating'.



Orthographic Map (Java) Stereographic S-pole Map Stereographic N-pole Map
 Equatorial Map Type in Lat/Lon Range Type in Path/Row Range
 Global Search Global granules only No geographic region

Choose a Date/Time Range (not required)

Standard Date Range

Date format: YYYY-MM-DD (1967-05-25) or MM/DD/YYYY (05/25/1967)
Time format: HH:MM (14:30) or HH:MM:SS (14:30:01)

You may also enter a date without a time, a start date only, or an end date only. Use the help link for information on default values.

Start Date: Time (UTC):
 End Date: Time (UTC):

Julian Date Range Annually Repeating Clear Fields

Standard Date Range

Choose Additional Options (not required)

Basic Options

- Return a maximum of [data granules](#) per data set (Range: 1 - 1000).
- (Do NOT use this option for Landsat-7/Terra searches - they will fail!) Only return data granules which have [browse](#) products.
- Allow searches to run for a maximum of minute(s)

Basic Options All Options

Figure 12: Choosing a Date/Time Range.

5: Primary Data Search - Start Search!

You are now ready to execute your search. Click the 'Start Search!' button to begin.

6: Results: Data Set Listing

If you ran a search on more than one data set (such as Level-1A and Level-1B), the results will be displayed, along with the number of granules returned (Figure 13). To view a list of the granules, click on the box in the 'Select' column for one or more data sets and click on 'List data granules'.



Results: Data Set:
Listing
[Help for this page](#)

User Name: mabrams

Address: http://edcimswww.cr.usgs.gov/ims-bin/pub/secured/nph-ims.cgi?endform=1&u=205741&sid=mabrams&mode=SEARCH&submode=COMMTRACE

Search and Order:
[User Preferences](#)
[Search Creation](#)
[Search Status](#)
> Results: Data Set
[Results Granule](#)
[My Folder](#)
[Shopping Cart](#)
[Exit to Home](#)

Help:
[Tutorial](#)
[FAQ](#)
[User Manual](#)
[Problems/Comments](#)
[User Support](#)
[Check Order Status](#)
[Other EDG Sites](#)
[HDF Viewing Tools](#)

Search Types:
[Primary Data Search](#)
[Local Granule ID](#)
[Data Granule ID](#)
[Detailed Document](#)
[Summary Document](#)

No items are currently selected.
[Customize this table](#) - change columns, sort order, number of rows, etc. [Text only version](#) - for printing or import into a spread sheet.

| Select | Options... | Data set | Number of Granules | Sources | Sensors |
|--------------------------|--|--|----------------------|---------|---------|
| <input type="checkbox"/> | Data set attributes Other links Summary document Detailed document | ASTER LIA RECONSTRUCTED UNPROCESSED INSTRUMENT DATA V002 | 100 (more are known) | TERRA | ASTER |
| <input type="checkbox"/> | Data set attributes Other links Summary document Detailed document | ASTER LIB REGISTERED RADIANCE AT THE SENSOR V002 | 50 (of 50) | TERRA | ASTER |

The last search you submitted was for...

- Data Set:** ASTER LIA RECONSTRUCTED UNPROCESSED INSTRUMENT DATA V002; ASTER LIB REGISTERED RADIANCE AT THE SENSOR V002
- Geographic Region:** 36.00000° to 35.00000° Lat, -116.00000° to -115.00000° Lon

If you [save this query to your machine](#), you can restore it later into the search form by entering its URL into the special field at the bottom of the search form.

Comments, Questions, or Problems? [Email us](#)
 Created by EOS Data Gateway version 3.2.1
 NASA Task Representative: Robyn Pfister (Mail Code 423, NASA/GSFC, Greenbelt, MD 20771)

Figure 13: Data Set Listing Result.

7: Results: Granule: Listing

When your results are returned, you will see a table of granules (Figure 14). A granule is the smallest aggregation of data, which is independently managed. For ASTER this is a single scene.

To view a browse image of the granule, click the 'View Image' button. Be sure to view the browse for each granule you intend to order, if it is available. The browse will give a good representation of data anomalies or cloud cover in the granule. For detailed information on a particular granule, click on 'Granule attributes'.

To order the data, click the box in the 'Select' column of the desired granule. Next, click the 'Add to cart' button:



Results: Granule: Listing

User Name: mabrms

data granules: selected on all pages

| Select | Options... | Granule | Special Processing Links | Start Date | Stop Date | Center Point | Data Set |
|--------------------------|--|---------------------------|--|-----------------------|-----------------------|--------------------------|--|
| <input type="checkbox"/> | Granule attributes Granule Pricing View image Request sample | SC-AST_L1B.002.2002055849 | Order higher-level product | 11 May 2000, 05:57:36 | 11 May 2000, 05:57:36 | 36.11° Lat, -115.27° Lon | ASTER LIB REGISTERED RADIANCE AT THE SENSOR V002 |
| <input type="checkbox"/> | Granule attributes Granule Pricing View image Request sample | SC-AST_L1B.002.2004249952 | Order higher-level product | 19 May 2000, 18:48:16 | 19 May 2000, 18:48:16 | 35.75° Lat, -114.86° Lon | ASTER LIB REGISTERED RADIANCE AT THE SENSOR V002 |
| <input type="checkbox"/> | Granule attributes Granule Pricing View image Request sample | SC-AST_L1B.002.2004249519 | Order higher-level product | 19 May 2000, 18:48:25 | 19 May 2000, 18:48:25 | 35.22° Lat, -115.01° Lon | ASTER LIB REGISTERED RADIANCE AT THE SENSOR V002 |
| <input type="checkbox"/> | Granule attributes Granule Pricing View image Request sample | SC-AST_L1B.002.2001880415 | Order higher-level product | 04 Jun 2000, 18:48:29 | 04 Jun 2000, 18:48:29 | 35.82° Lat, -115.33° Lon | ASTER LIB REGISTERED RADIANCE AT THE SENSOR V002 |
| <input type="checkbox"/> | Granule attributes Granule Pricing View image Request sample | SC-AST_L1B.002.2001880416 | Order higher-level product | 04 Jun 2000, 18:48:38 | 04 Jun 2000, 18:48:38 | 35.28° Lat, -115.48° Lon | ASTER LIB REGISTERED RADIANCE AT THE SENSOR V002 |
| <input type="checkbox"/> | Granule attributes Granule Pricing View image Request sample | SC-AST_L1B.002.2002055854 | Order higher-level product | 12 Jun 2000, 05:57:21 | 12 Jun 2000, 05:57:21 | 36.11° Lat, -115.29° Lon | ASTER LIB REGISTERED RADIANCE AT THE SENSOR V002 |
| <input type="checkbox"/> | Granule attributes Granule Pricing View image Request sample | SC-AST_L1B.002.2001936732 | Order higher-level product | 02 Oct 2000, 05:56:07 | 02 Oct 2000, 05:56:07 | 36.11° Lat, -115.30° Lon | ASTER LIB REGISTERED RADIANCE AT THE SENSOR V002 |
| <input type="checkbox"/> | Granule attributes Granule Pricing View image Request sample | SC-AST_L1B.002.2002204536 | Order higher-level product | 17 Oct 2000, 18:53:01 | 17 Oct 2000, 18:53:01 | 36.12° Lat, -115.19° Lon | ASTER LIB REGISTERED RADIANCE AT THE SENSOR V002 |
| <input type="checkbox"/> | Granule attributes Granule Pricing View image Request sample | SC-AST_L1B.002.2002816746 | Order higher-level product | 26 Mar 2001, 18:49:45 | 26 Mar 2001, 18:49:45 | 36.29° Lat, -116.31° Lon | ASTER LIB REGISTERED RADIANCE AT THE SENSOR V002 |
| <input type="checkbox"/> | Granule attributes Granule Pricing View image Request sample | SC-AST_L1B.002.2005894700 | Order higher-level product | 26 Mar 2001, 18:49:45 | 26 Mar 2001, 18:49:45 | 36.29° Lat, -116.31° Lon | ASTER LIB REGISTERED RADIANCE AT THE SENSOR V002 |

You are currently viewing items 1 through 10 out of 50 total.

1 - 10 | 11 - 20 | 21 - 30 | 31 - 40 | 41 - 50

Figure 14: Data Granules Listing Result.

8: Shopping Cart - Step 1: Choose Ordering Options

Click the 'Order options' button and choose your output media (Figure 15). You will have the option to either apply the output media and processing parameters to all granules or to just one granule. Click the 'OK! Accept my choice & return to the shopping cart' button to proceed.

You will want to repeat this for each remaining granule if you are ordering data from more than one data set, or if you did not apply the ordering options to all granules. When finished with your processing parameters, click the 'Go to Step 2: Order Form' button.





User Name
mabrams

Search and Order

[User Preferences](#)
[Search Creation](#)
[Search Status](#)
[Results:Data Set](#)
[Results:Granule](#)
[My Folder](#)
> [Shopping Cart](#)
[Exit to Home](#)

Help

[Tutorial](#)
[FAQ](#)
[User Manual](#)

[Problems/Comments](#)
[User Support](#)
[Check Order Status](#)

Shopping Cart:
Step 1: Choose Ordering Options
[Help for this page](#)

You selected a total of 1 data granule.

- Your selection was **added** to your shopping cart.

There is currently 1 item in your shopping cart, 0 items are ready to be ordered.

Before you can go to **Step 2: Order Form** you must choose ordering options using the **Order Options** button next to each item that needs it.

Remove ALL items from shopping cart. 

Check Order Status of a previous order.



| Options... | Remove | Item | Start Date | Stop Date | Center Point |
|---|---|---------------------------|-----------------------|-----------------------|---------------------------|
|  |  | SC:AST_L1B.002:2004249952 | 19 May 2000, 18:48:16 | 19 May 2000, 18:48:16 | 35.75° Lat, - 114.86° Lon |

Figure 15: Choosing Ordering Options.

9: Shopping Cart: - Step 2: Order Form

Enter your appropriate address in the contact, shipping and billing address fields (Figure 16). You are required to supply information in the red fields. If you are a registered user, this page will be completed for you. When finished, choose your affiliation and click the 'Go to Step 3: Review Order Summary' button.



EOS Data Gateway: Step 2: Order Form - Microsoft Internet Explorer

File Edit View Favorites Tools Help

Back Forward Stop Search Favorites Media

Address http://edcimswww.cr.usgs.gov/ims-bin/pub/secured/nph-ims.cgi/u206586



User Name
mabrams

Search and Order
[User Preferences](#)
[Search Creation](#)
[Search Status](#)
[Results Data Set](#)
[Results Granule](#)
[My Folder](#)
> Shopping Cart
[Exit to Home](#)

Help
[Tutorial](#)
[FAQ](#)
[User Manual](#)

Problems/Comments
[User Support](#)
[Check Order Status](#)
[Other EDG Sites](#)
[HDF Viewing Tools](#)

Search Types
[Primary Data Search](#)
[Local Granule ID](#)
[Data Granule ID](#)
[Detailed Document](#)
[Summary Document](#)

Shopping Cart:
Step 2: Order Form
[Help for this page](#)

Please fill out the **user, shipping, and billing information** on the form below, then click on the **Go to Step 3: Review Order Summary** button at the bottom of the page. place it if you are satisfied.

Required fields in the form below are starred *Like This.

Your Contact Address:

Title: *First Name: (none) MICHAEL Initial: *Last Name: ABRAMS

Organization: *Internet E-Mail Address: mike@lithos.jpl.nasa.gov

*Street Address: 4800 oak grove

*City: pasadena

*Select State (US only): CALIFORNIA Or Enter State/Province: -- None --
To enter a state/province, select None from the selection menu and enter state/province above.

Zip/Postal Code:

*Select Country: UNITED STATES Or Enter Country: -- None --
To enter a country, select None from the selection menu and enter country above.

*Telephone: 818-354-0937 Fax:

Shipping Address: Same as contact address (above)
 Billing Address: Same as contact address (above)

Figure 16: Order Form.

10: Shopping Cart: - Step 3: Order Summary

Review the order summary. If all of the information is correct, click the 'Go to Step 4: Submit Order!' button.

11: Order Submitted

Your order has now been submitted. You will receive automatic email(s) confirming the receipt of your order. The EDC email will summarize your order, cost, and provide information on Modes of Payment. Payment must be received before order processing can begin. Please contact LP-DAAC to arrange payment and include your order number on all modes of payment.



9.0 ASTER Higher-Level Data Products Ordering Mechanism

All the higher-level (Level-2) ASTER geophysical products (except absolute and relative DEMs) are produced using an ASTER-L1B as its input. The routinely-produced on-demand products including their Long and Short names are:

Routinely-Produced Level-2 Products

- | | |
|--|----------------|
| 1. ASTER L2 Decorrelation Stretch (VNIR) | AST_06V |
| 2. ASTER L2 Decorrelation Stretch (SWIR) | AST_06S |
| 3. ASTER L2 Decorrelation Stretch (TIR) | AST_06T |

You can search, browse and order these products from the **EOS Data Gateway**.

On-Demand Level-2 Products

- | | |
|---|-----------------|
| 1. ASTER On-Demand L2 Decorrelation Stretch (VNIR) | AST_06VD |
| 2. ASTER On-Demand L2 Decorrelation Stretch (SWIR) | AST_06SD |
| 3. ASTER On-Demand L2 Decorrelation Stretch (TIR) | AST_06TD |
| 4. ASTER On-Demand L2 Brightness Temperature at the Sensor | AST_04 |
| 5. ASTER On-Demand L2 Emissivity | AST_05 |
| 6. ASTER On-Demand L2 Surface Reflectance (VNIR & SWIR) | AST_07 |
| 7. ASTER On-Demand L2 Surface Kinetic Temperature | AST_08 |
| 8. ASTER On-Demand L2 Surface Radiance (VNIR & SWIR) | AST_09 |
| 9. ASTER On-Demand L2 Surface Radiance (TIR) | AST_09T |
| 10. ASTER On-Demand L2 Polar Surface & Cloud Classification | AST13POL |

You can order these on-demand products using the **ASTER On-Demand Gateway**. You will be led there through a link (Order higher-level product) on the EDG's Level-1B granules search page next to the granule-listing column. This site allows you to select a product (such as reflectance), and either accept the default parameters, or customize by selecting appropriate alternative options. There is a brief on-line tutorial for beginning users on how to place an order for ASTER on-demand products: http://edcdaac.usgs.gov/asterondemand/aod_tutorial.html

On-Demand Level-3 Products

- | | |
|--|-----------------|
| 1. ASTER Digital Elevation Model (DEM) | AST14DEM |
|--|-----------------|

The only Level-3 products generated from an ASTER L1A data set are:

- An Absolute Digital Elevation Model (DEM). This product requires you to submit Ground Control Points (GCPs) for your area of interest. To accomplish this, you must first order the L1A data, locate your GCP's on both the 3N and 3B images, and supply these pixel coordinates along with the GCP coordinate locations.



- A Relative DEM. This does not require a requestor to provide GCPs. You only have to copy and paste the L1A Granule ID in the appropriate place on the on-demand product order page, and submit the order.

You can order on-demand DEMs using the **ASTER On-Demand Gateway**. You will be led there through a link (Order custom DEM.) on the EDG's Level-1A granules search page next to the granule-listing column. Follow the instructions there to order a relative or absolute DEM.

Archived Level-3 DEM Products

You can search for and order archived DEMs from the **EOS Data Gateway** by selecting the ASTER Digital Elevation Model data set.

10.0 Data Acquisition Requests

Data Acquisition Requests (DARs) are user requests to have ASTER acquire new data over a particular site at specified times. If the desired ASTER observations have not yet been acquired or even requested, a requestor can become an authorized ASTER User, and can submit a data acquisition request (DAR) via the DAR Tool. To register as an authorized ASTER User, use the link below which will take you to the web site for registering, and explains the procedure:

<http://asterweb.jpl.nasa.gov/gettingdata/authorization/default.htm>

Once you are registered, you can go to the on-line ASTER DAR Tool web site to enter your request:

<http://e0ins02u.ecs.nasa.gov:10400/>

Be sure to read the “Getting Started” information for help on using the tool, and getting any plug-ins if necessary.

11.0 ASTER Applications

11.1 Cuprite, Nevada

The Cuprite Mining District is located in west-central Nevada, and is one of a number of alteration centers explored for precious metals. Cambrian sedimentary rocks and Cenozoic volcanic rocks were hydrothermally altered by acid-sulfate solutions at shallow depth in the Miocene, forming three mappable alteration assemblages: 1) silicified rocks containing quartz and minor alunite and kaolinite; 2) opalized rocks containing opal, alunite and kaolinite; 3) argillized rocks containing kaolinite and hematite. A general picture of the alteration is shown in Figure 17, combining bands 4,6 and 8 in RGB and processed to increase the color saturation.



Figure 17: Cuprite Mining District, displayed with SWIR bands 4-6-8 as RGB composite.
(Note: Area covered is 15 x 20 km)

Red-pink areas mark mostly opalized rocks with kaolinite and/or alunite; the white area is Stonewall Playa; green areas are limestones, and blue-gray areas are unaltered volcanics.

Data from the SWIR region were processed to surface reflectance by LP-DAAC and image spectra were examined for known targets at Cuprite. Evidence of SWIR crosstalk was apparent, making the data difficult to use for spectral analysis using direct comparisons with library or field spectra. To reduce the cross-talk artifacts, a spectrum of Stonewall Playa was used as a bright target, resampled to the ASTER wavelengths, and divided into the SWIR reflectance data. Library spectra were compiled for minerals known to occur at Cuprite; they were then resampled to ASTER SWIR wavelengths. These spectra were used with a supervised classification algorithm, Spectral Angle Mapper, to map similar spectral occurrences in the SWIR data. The result of this classification is shown in Figure 18.

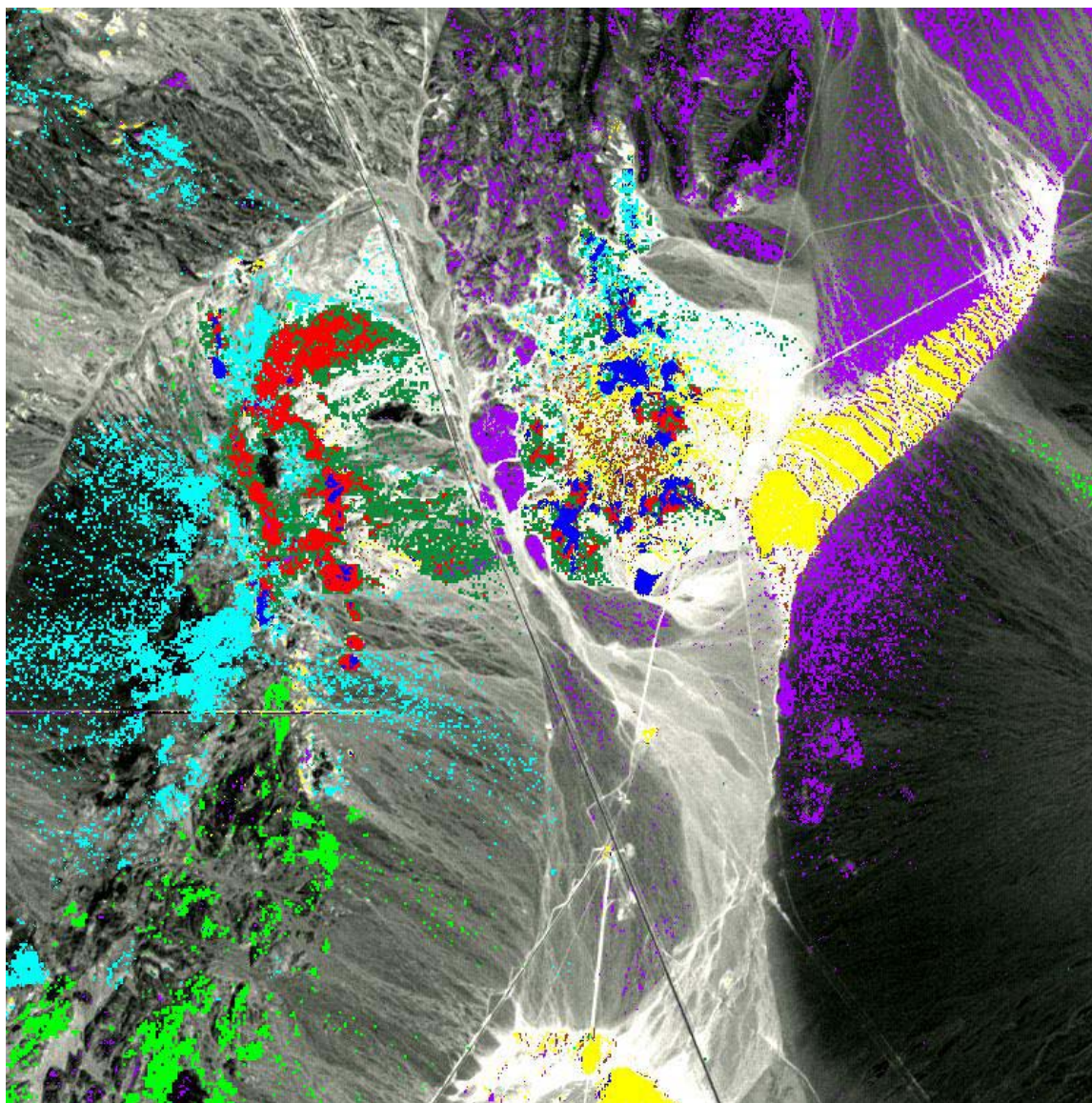

Figure 18: Spectral Angle Mapper Classification of Cuprite SWIR data.

(Note: blue = kaolinite; red = alunite; light green = calcite; dark green = alunite+kaolinite; cyan = montmorillonite; purple = unaltered; yellow = silica or dickite)

When this map was compared with more detailed mineral classification produced from AVIRIS data, the correspondence is excellent. The resampled library spectra are shown in Figure 19 compared with ASTER image spectra extracted from 3x3 pixel areas.

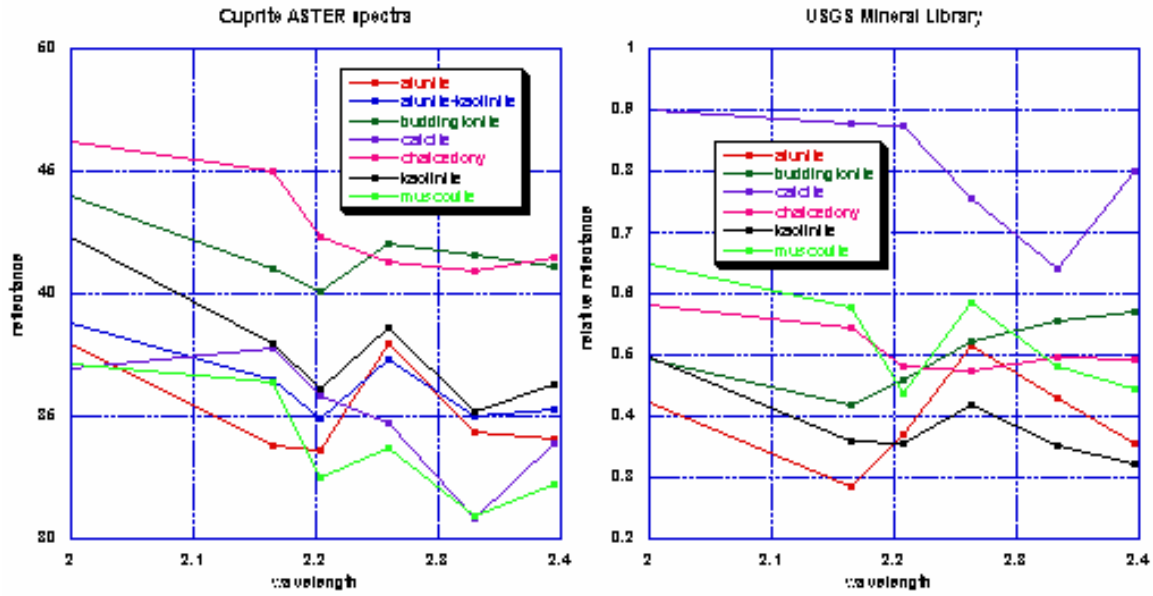

Figure 19: ASTER image spectra (left) and library spectra (right) for minerals mapped at Cuprite.

11.2 Lake Tahoe

11.2.1 Objective

The objective of the Lake Tahoe CA/NV case study is to illustrate the use of ASTER data for water-related studies.

11.2.2 Introduction

Lake Tahoe is a large lake situated in a granite graben near the crest of the Sierra Nevada Mountains on the California - Nevada border, at 39° N, 120° W. The lake level is approximately 1898 m above MSL. The lake is roughly oval in shape with a N-S major axis (33 km long, 18 km wide), and has a surface area of 500 km² (Figure 20).

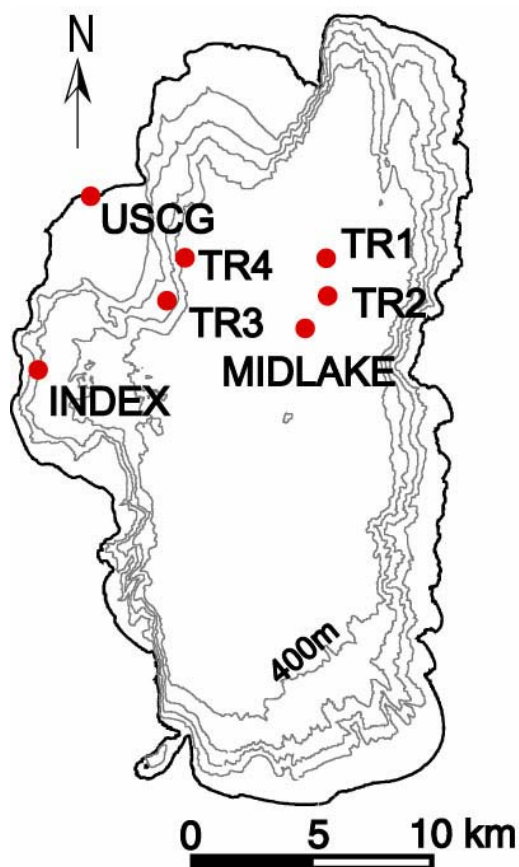

Figure 20: Outline map of Lake Tahoe, CA/NV.

The land portion of the watershed has an area of 800 km². Lake Tahoe is the 11th deepest lake in the world, with an average depth of 330 m, maximum depth of 499 m, and a total volume of

156 km³. The surface layer of Lake Tahoe deepens during the fall and winter. Complete vertical mixing only occurs every few years. Due to its large thermal mass, Lake Tahoe does not freeze in winter. There are approximately 63 streams flowing into the lake and only one river flowing out of the lake. Lake Tahoe is renowned for its high water clarity. However, the water clarity has been steadily declining from a maximum secchi depth of 35 m in the sixties to its current value of ~20 m. Research by University of California (UC), Davis has identified that the decline is in part due to increased algal growth facilitated by an increase in the amount of nitrogen and phosphorus entering the lake and, in part, due to accumulation of small suspended inorganic particulates derived from accelerated basin-wide erosion and atmospheric inputs.

11.2.3 Field Measurements

In order to validate the data from the MODIS and ASTER instruments, the Jet Propulsion Laboratory (JPL) and UC Davis (UCD) are currently maintaining four surface sampling stations on Lake Tahoe (Hook et al. 2002). The four stations (rafts/buoys) are referred to as TR1, TR2, TR3 and TR4 (Figure 20). Each raft/buoy has a single custom-built self-calibrating radiometer for measuring the skin temperature and several bulk temperature sensors. The radiometer is mounted on a pole approximately 1m above the surface of the water that extends beyond the raft (Figure 21).

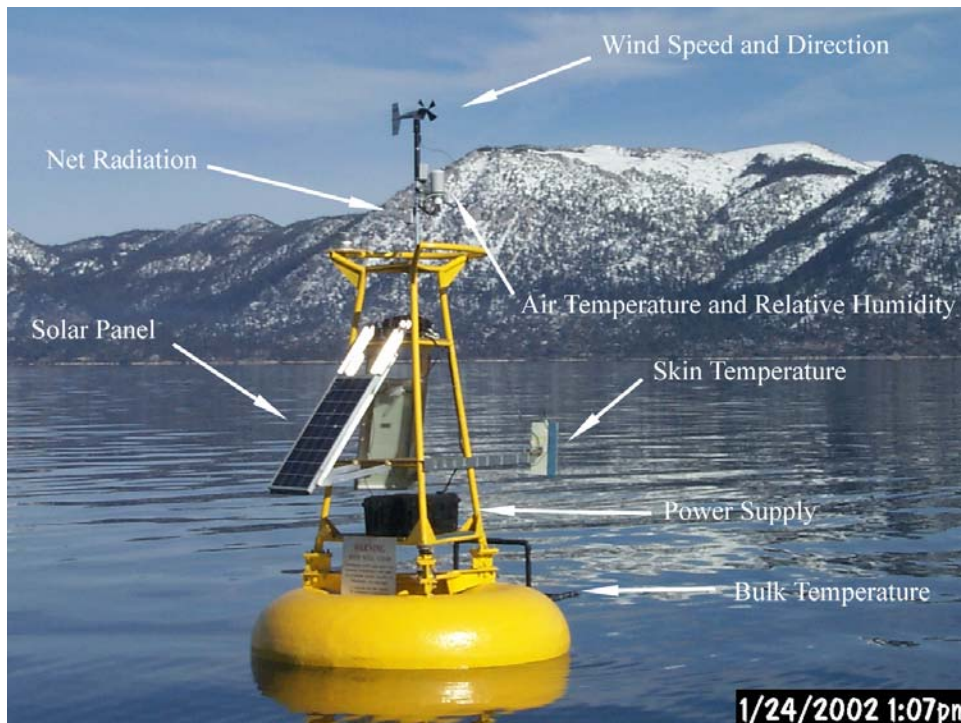

Figure 21: Raft Measurements.

The radiometer is orientated such that it measures the skin temperature of the water directly beneath it. The radiometer is contained in a single box that is 13 cm wide, 43 cm long, and 23 cm



high (Figure 21). The sensor used in the radiometer is a thermopile detector with a germanium lens embedded in a copper thermal reservoir. The sensor passes radiation with wavelengths between 7.8 and 13.6 μm . The unit is completely self-contained and has an on-board computer and memory and operates autonomously. The unit can store data on-board for later download or automatically transmit data to an external data logger. The unit can be powered for short periods (several hours) with its internal battery, or can be powered for longer periods with external power. In this study the radiometer is powered externally and data are transferred to an external data logger. The radiometer uses a cone blackbody in a near-nulling mode for calibration and has an accuracy of ± 0.1 K. The accuracy of the radiometers was confirmed in a recent cross-comparison experiment with several other highly accurate radiometers in both a sea trial and in laboratory comparisons. It should be noted the current design of both the radiometers do not include a sky view and therefore the correction for the reflected sky radiation is made using a radiative transfer model (MODTRAN).

The bulk water temperature is measured with several temperature sensors mounted on a float tethered behind the raft/buoy (Figure 21). The float was built in the shape of a letter H and is 203 cm long and 70 cm wide. At the end of each point of the letter H is a short leg at right angles to the float and the temperature sensors are attached to the end of the leg approximately 2cm beneath the surface. Multiple temperature sensors are used to enable cross-verification and each float has up to 12 temperature sensors all at the same depth. The temperature sensors used include the Optic Stowaway and Hobo Pro Temperature Loggers available from Onset Corporation (<http://www.onsetcomp.com/>) and a TempLine system available from Apprise Technologies (<http://www.apprisetech.com/>). The Optic Stowaway Temperature Loggers include both the sensor and data logger in a single sealed unit with a manufacturer-specified *maximum* error of ± 0.25 $^{\circ}\text{C}$. The Hobo Pro Temp/External Temperature logger has an external temperature sensor at the end of a short cable that returns data to a logger and a manufacturer-specified *maximum* error of ± 0.2 $^{\circ}\text{C}$. The TempLine system consists of 4 temperature sensors embedded at different positions along a cable that is attached to a data logger. The TempLine system has a manufacturer specified error of $\pm 0.1^{\circ}$ C. Note all sensors are placed at the same depth ensuring both redundancy and cross-verification. The calibration accuracy of the Onset temperature sensors was checked using a NIST traceable water bath. NIST traceability was provided by use of a NIST-certified reference thermometer. In all cases the sensors were found to meet the manufacturer specified *typical* error of ± 0.12 C.

Data collected by the external data logger (radiometer and TempLine system) can be downloaded automatically via cellular telephone. Currently data from the external data logger are downloaded daily via cellular telephone modem to JPL allowing near real-time monitoring. A full set of measurements is made every 2 minutes. However, the units attached to the external data logger can remotely be re-programmed if a different sampling interval is desired. The initial rafts are currently being replaced by buoys as pictured above which also include a meteorological station providing wind speed, wind direction, air temperature, relative humidity and net radiation (Figure 21).

Additional UCD atmospheric deposition collectors are located on TR2 and TR3. Both JPL and UCD maintain additional equipment at the US Coast Guard station that provides atmospheric information (Figure 22). This includes a full meteorological station (wind speed,

wind direction, air temperature, relative humidity), full radiation station (long and shortwave radiation up and down), a shadow band radiometer and an all sky camera. The shadow band radiometer provides information on total water vapor and aerosol optical depth.

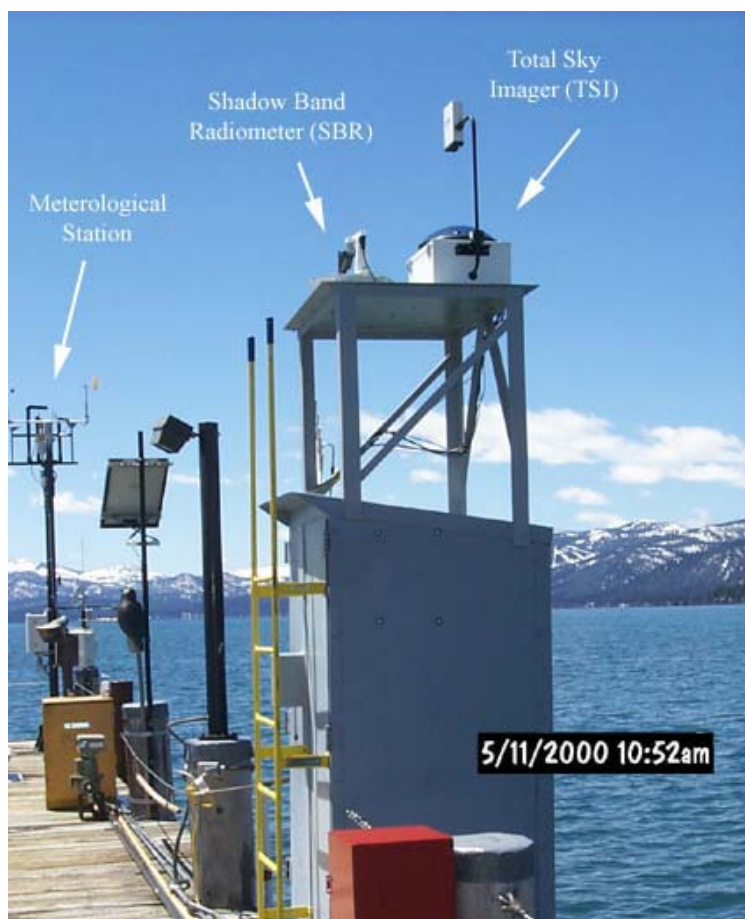

Figure 22: Field measurements at the US Coast Guard.

Measurements of algal growth rate using ^{14}C , nutrients (N, P), chlorophyll, phytoplankton, zooplankton, light, temperature and secchi disk transparency are also made tri-monthly at the Index station (Figure 10) and monthly samples for all constituents except algal growth and light are made at the Mid-lake station (Figure 20). Many samples are taken annually around the Tahoe Basin to examine stream chemistry and snow and atmospheric deposition constituents.

11.2.4 Using ASTER to measure water clarity

Currently the decline in water clarity at Lake Tahoe is measured using a secchi disk – a white disk that is lowered into the water until it is no longer visible. The UC Davis Tahoe Research Group have been making secchi disk measurements since the mid 60’s at two locations on the lake (Midlake and Index – see Figure 20). Such measurements have been used to monitor the decline in clarity from a maximum of 35 m when measurements began, to the current low of 20 m. These measurements are crucial for monitoring temporal changes in clarity but provide little

information on spatial variations in clarity across and around the lake. Knowledge of spatial variations in clarity could prove useful in identifying areas of high nutrient or sediment input into the lake.

Examination of a color infrared composite image derived from ASTER for Lake Tahoe (Figure 23) indicates that due to the high clarity, the bottom of the lake is visible for some distance from the shore.

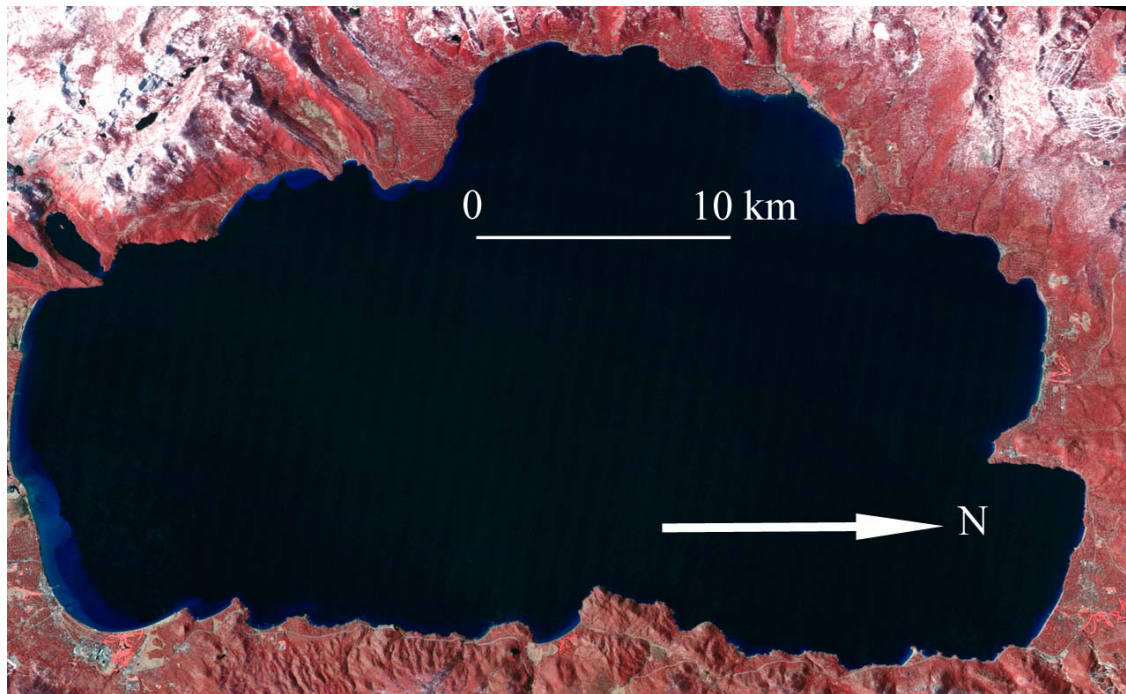

Figure 23: Color Infrared Composite of ASTER bands 3, 2, 1 as R, G, B respectively.
Red areas indicate vegetation, white areas are snow

Places where the bottom of the lake is visible appear dark blue, for example the southern margin of the lake. The bottom can be seen for the greatest distance from the shore in ASTER band 1 and this band can be color-coded to show variations in the intensity of the bottom reflectance (Figure 24).

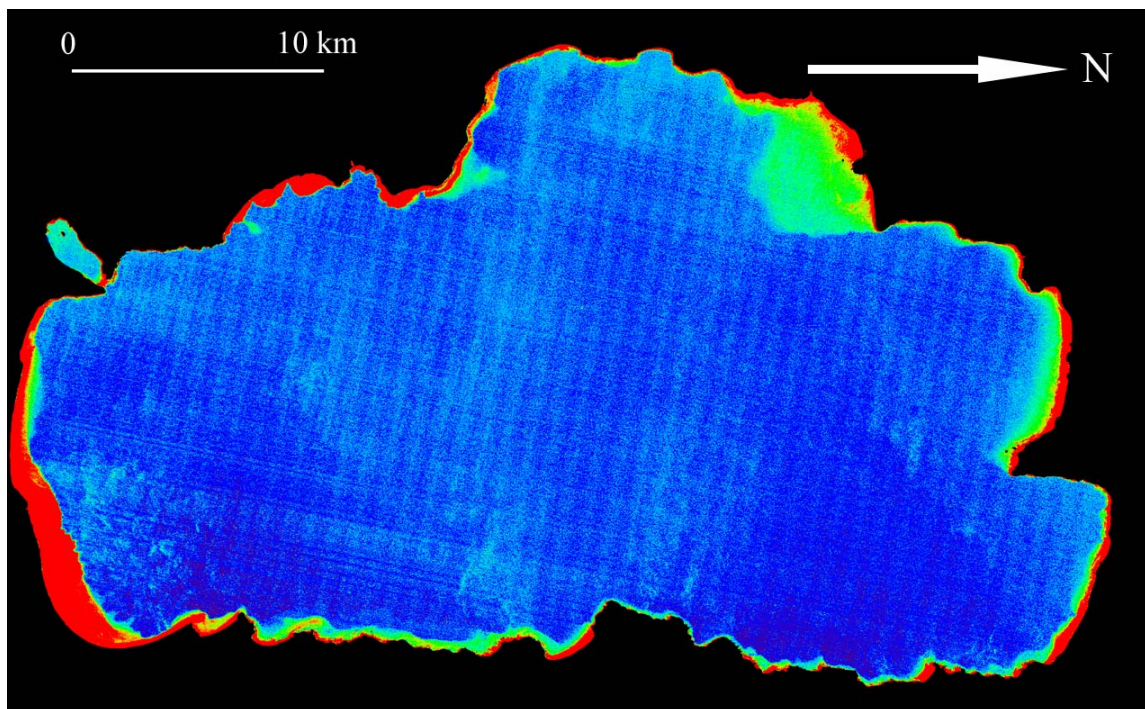

Figure 24: ASTER band 1 (0.52-0.60 μm) color-coded to show variations in the intensity of the near-shore bottom reflectance.

In this image, areas where the bottom is visible are colored red and green (greater bottom reflectance is shown in red). Where the lake is blue the bottom cannot be seen. The depth to which the bottom is visible varies depending on the clarity of the water. In order to investigate this further, an accurate bathymetric map was registered to the ASTER data. The accuracy of the bathymetric map is $\sim 0.5\%$ of the water depth. The bathymetric map is shown in Figure 25 color-coded with greater depths shown in blue and shallower depths shown in red.

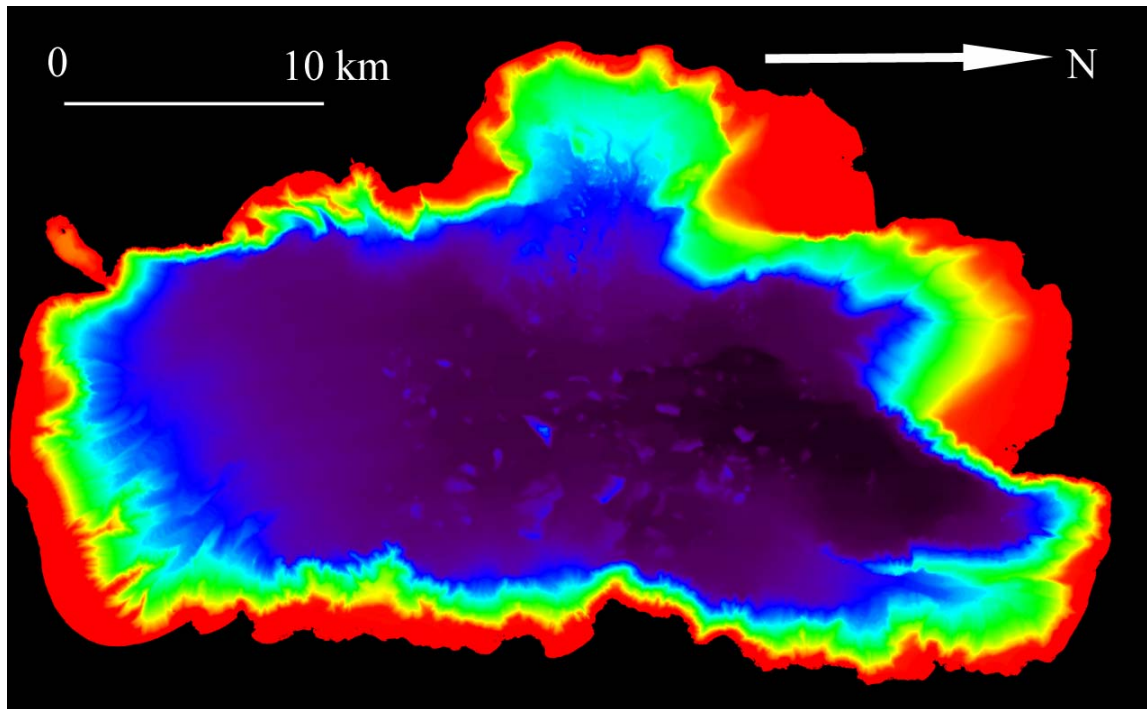
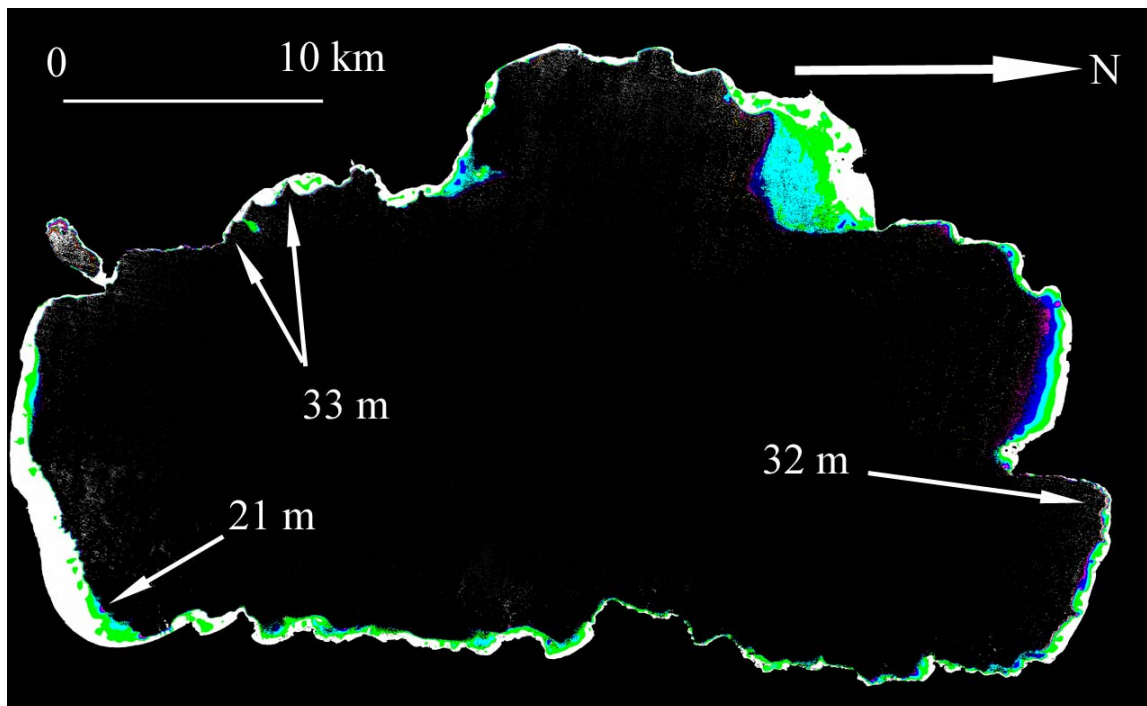

Figure 25: Bathymetric map of Lake Tahoe CA/NV.

Once the bathymetric map is registered to the ASTER image, the depth at which the bottom is no longer visible can be determined and can be used to produce a near shore clarity map shown in Figure 26.



**Figure 26: Near-shore clarity map derived from ASTER data and a bathymetric map.**

Examination of Figure 26 indicates some places where the lake is exceptionally clear and other areas where it is less so. For example the areas in the southwest and northeast are particularly clear whereas the area in the southeast is less clear. There is little sediment input in the southwest and northeast whereas the Upper Truckee River flows in from the south and strongly affects the southeast. Further work is underway to validate the accuracy of this map and look for seasonal changes in clarity as well as changes over time.

11.2.5 Using ASTER to Measure Circulation

In addition to making measurements in the reflected infrared, the ASTER instrument also measures the radiation emitted in the thermal infrared part of the spectrum. These data can be used to measure the surface temperature and produce maps of lake surface temperature. Such maps are valuable in understanding a variety of lake processes, such as wind-induced upwelling events and surface water transport patterns.

In order to derive the surface temperature it is necessary to correct the data for atmospheric effects. Two approaches are commonly used to correct the data. The most common approach is a split-window algorithm. In the split-window algorithm the at-sensor radiances are regressed against simultaneous ground measurements to derive a set of coefficients that can then be used to correct other datasets without ground measurements. Alternatively a physics-based approach can be used which couples a surface temperature and emissivity model with a radiative transfer model. The ASTER team has developed a physics based approach for extracting temperature and emissivity and a user can order either a surface temperature (AST_08) or surface emissivity (AST_05) product.

The image below (Figure 27) shows an at-sensor brightness temperature image for Lake Tahoe from ASTER thermal data acquired at night on June 3rd 2001. Examination of the image indicates a strong cold plume of water originating in the west, traveling across the lake to the east shore, then spreading north and south. This cold plume is the result of a wind-induced upwelling event in the west. The upwelling is induced by strong, persistent winds from the southwest which move the surface water to the east allowing the deep cold water in the west to upwell. The cold water is nutrient- rich compared with the warmer surface waters which have been depleted of nutrients. The temperature images from ASTER can be used to map these nutrient pathways which help explain the distribution of organic matter and fine sediments around the lake.

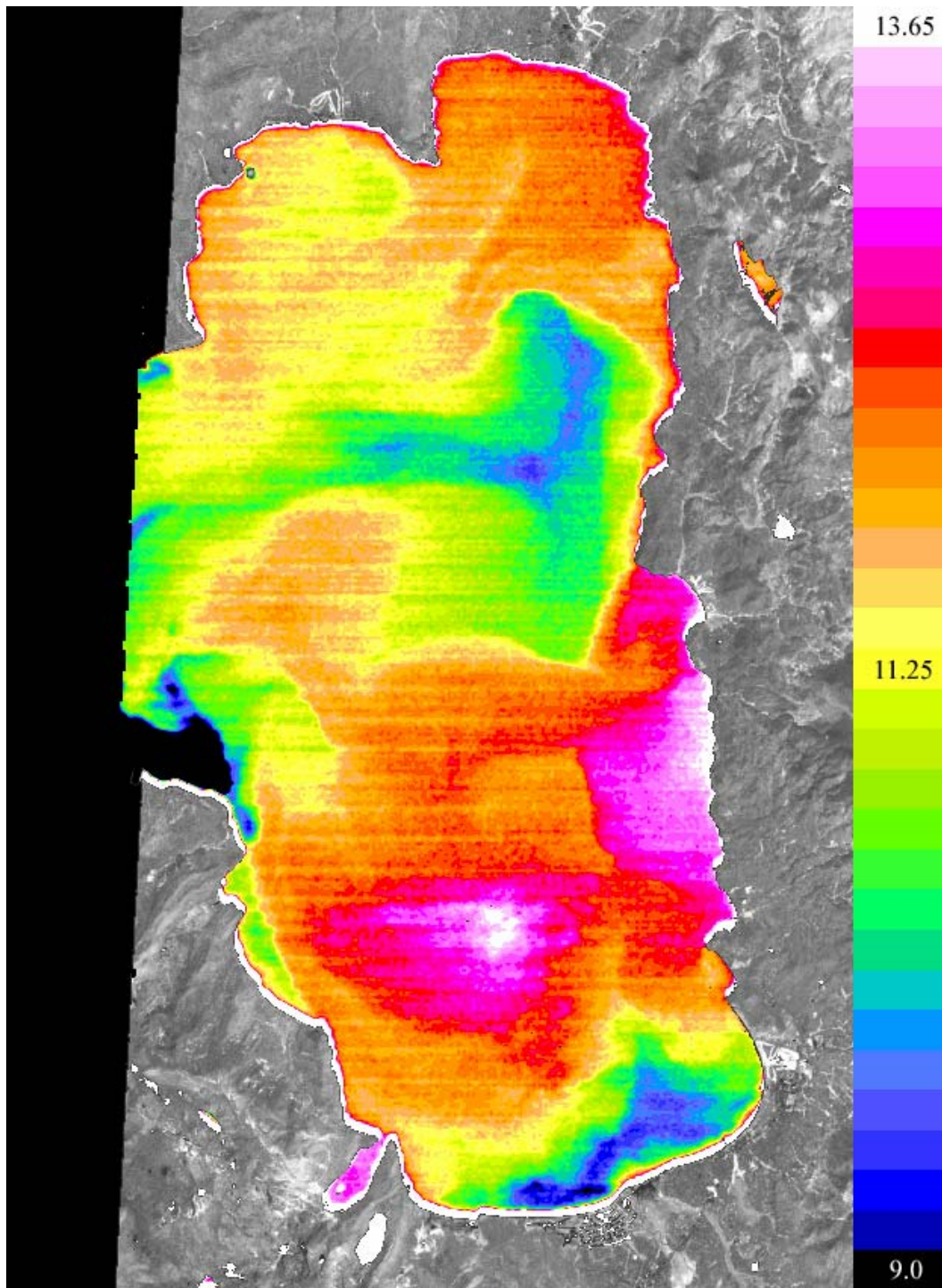

Figure 27: ASTER Band-13 Brightness Temperature Image of Lake Tahoe from Thermal Data Acquired June 3, 2001.



12.0 Geo-Referencing ASTER Level-1B Data

12.1 Introduction

All image processing software packages employ distinctive procedures for projecting and geo-referencing image data. Some software packages have incorporated specific import routines that geo-reference ASTER data on ingest, however, most have not. The purpose of this document is not to provide step-by-step instructions for loading ASTER Level-1B data into any particular software package, but rather to outline the various components necessary to geo-reference the data in most application software. All this information is also applicable to the Level-2 On-Demand Products derived from ASTER Level-1B data except for the ASTER Digital Elevation Model (DEM) product which is generated from an ASTER Level-1A data set.

12.2 Accessing ASTER Level-1B Metadata

The information needed to geo-register ASTER Level-1B data is located within the “embedded” metadata (i.e., the metadata contained within the header of the ASTER image data). To access that metadata you will need software capable of reading HDF-EOS-formatted data. A list of public domain software that handle HDF-EOS is available from <http://edcdaac.usgs.gov/dataformat.html>. Note that the “.met” file accompanying the ASTER data file does NOT contain all the required information to geo-reference ASTER data, and therefore, we suggest utilizing the embedded hdf metadata.

Depending on your software, any or all of the following information may be necessary to geo-reference your ASTER Level-1B image (Table 7):



| Category | Name as Referenced in the HDF Metadata File | HDF-EOS Subcategory | Description |
|----------------------------|---|---|--|
| Scene Corner Coordinates | SCENEFOURCORNERS | productmetadata.0 | This denotes the coordinates of the upper-left, upper-right, lower-left and lower-right corners of the scene (latitude and longitude) where: lat: geodetic latitude long: geodetic longitude Unit: Degrees |
| Map Projection | MAPPROJECTIONNAME Or MPMETHOD (band#) | coremetadata.0 productmetadata.v productmetadata.s productmetadata.t | The name of the mapping method for the data. The available map projections are: Equi-Rectangular Lambert Conformal Conic Polar Stereographic Space Oblique Mercator, & Universal Transverse Mercator Map Projection Method: 'EQRECT', 'LAMCC', 'PS', 'SOM', or 'UTM', |
| Datum | Not specified in the metadata | Not specified in the metadata | WGS84 (for all ASTER data processed at GDS) |
| Zone (UTM) | UTMZONECODE (band#) | productmetadata.v productmetadata.s productmetadata.t | For VNIR, SWIR and TIR: Zone code for UTM projection (when mapping without UTM: 0 fixed). If southern zone is intended, use negative values |
| Number of Pixels and Lines | IMAGEDATAINFORMATION | productmetadata.v productmetadata.s productmetadata.t | VNIR: 4980 pixels x 4200 lines (1 BPP)* VNIR (3B): 4980 pixels x 4600 lines (1 BPP) SWIR: 2490 pixels x 2100 lines (1 BPP) TIR: 830 pixels x 700 lines (2 BPP) *BPP: Bytes Per Pixels |
| Rotation Angle | MAPORIENTATIONANGLE | productmetadata.0 | This denotes the angle between the path-oriented image and the map-oriented image within the range -180.0 to 180.0 Unit: Degrees |
| Cell Size | SPATIALRESOLUTION | productmetadata.0 | The nominal spatial resolution (Unit: Meters): VNIR: 15, SWIR: 30, TIR: 90 |
| Resampling Method | RESMETHOD (band#) | productmetadata.v productmetadata.s productmetadata.t | Resampling Method: CC: Cubic Convolution, BL: Bilinear NN: Nearest Neighbor |

Table 7: Specific Metadata Attributes Required for Geo-Referencing ASTER Level-1B Data.



12.3 ASTER Level-1B Geo-Referencing Methodology

How one geo-registers an ASTER Level-1B image will vary depending on what image processing software package one uses. The following is a generic description of the process independent of any particular image processing system. All the required attributes for geo-registering an ASTER Level-1B image are available from the embedded metadata in the hdf file and include:

- SCENEFOURCORNERS
- MAPORIENTATIONANGLE
- PROCESSINGPARAMETERS (Projection information)
 - MPMETHOD
 - UTMZONECODE
 - RESMETHOD

SCENEFOURCORNERS represent the geodetic latitude and longitude coordinates (UPPERLEFT, UPPERRIGHT, LOWERLEFT, LOWERRIGHT) of the ASTER Level-1B scene.

The MAPORIENTATIONANGLE denotes the angle of rotation between the path-oriented image and the transformed map-projected coordinates. Ranging from -180° to $+180^{\circ}$, it provides the amount by which the ASTER Level-1B image is rotated from True North.

The PROCESSINGPARAMETERS object group lists a number of attributes among which MPMETHOD lists the projection used and UTMZONECODE provides the zone information. The PROCESSINGPARAMETERS object group is numbered 1 through 14 for each of the ASTER bands (VNIR, SWIR and TIR). The component objects within this group are also numbered likewise.

You will have to edit the header information for the chosen set of ASTER Level-1B bands that you need to geo-register. The header information for hdf files are encapsulated within the main hdf file itself (this is different from the external .met file). Your image processing system (assuming it handles the hierarchical data format) will likely have a mechanism to display the embedded header information and save it to an ASCII file, and also edit their attributes.

The steps comprising the process of geo-registering your ASTER image will vary with each application software system, and hence cannot be generalized. But some of the broadly common requirements might include:

- specifying the values for the corner column-row (pixel-line) image coordinates
- specifying the correct pixel resolution for x and y
- specifying the MAPORIENTATIONANGLE value
- specifying the output projection parameters including the projection and its related information, datum etc. Presently, the datum information is not included in the metadata.

Committing the above changes and re-displaying your Level-1B should ensure that the image is displayed in geographic latitude-longitude coordinates. You can further verify the quality of geo-registration by overlaying a reliable vector coverage layer of the same area that has the same projection coordinates as your ASTER Level-1B image.

12.4 Unique Features of ASTER Level-1B Data

12.4.1 Pixel Reference Location

There is a fundamental difference between the alignment of the image bands and how their pixels are referenced. Assuming that we have the full complement of data from all the three sensors (VNIR, SWIR, and TIR), the VNIR Band-2 is used as the reference band, and data for all the three sensors are aligned by the upper-left **corners** of their upper-left pixels. When there are only SWIR and TIR bands present, the SWIR Band-6 is used as the reference band. When a Level-1B data set contains only TIR data, the TIR Band-11 is used as the reference band.

The SceneFourCorners upper-left is calculated using Band-2 of the VNIR (or Band-6 of SWIR or Band-11 of TIR as warranted by the data acquisition), and represents the **center** of the upper left image pixel. You may need to make necessary adjustments to the x and y values representing the centers of any particular sensor's upper-left image pixel depending on how your specific image processing software references the pixel location (see Figure 28 below where “**x**” is the SceneFourCorners upper-left).

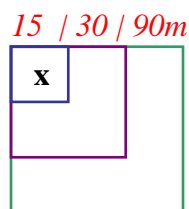

Figure 28: Upper-left pixel of VNIR, SWIR and TIR bands in an ASTER Level-1B data set.

12.4.2 Footprint of an ASTER Level-1B Image

The footprint of an ASTER Level-1B image is somewhat unique when viewed in the context of the alignment of its SceneFourCorners. Only the upper-left pixel of the SceneFourCorners lies within an ASTER Level-1B (or Level-2) image extent. The other three corner coordinates represent locations that are one pixel beyond the extent of the image (Figure 29).

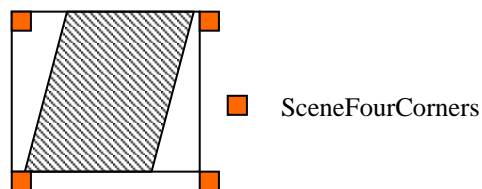



Figure 29: ASTER L1B Footprint in the Context of the SCENEFOURCORNERS Alignment.

12.4.3 Path- or Satellite-Orientation of an ASTER Level-1B Image

The ASTER instrument aboard the Terra satellite platform orbits the Earth with a 10:30 AM (GMT) equator-crossing time. This renders day-time orbits to be descending passes while night-time orbits are ascending passes. The `MapOrientationAngle` denotes the angle of rotation between the path-oriented image and the transformed map-projected coordinates. Ranging from -180° to $+180^{\circ}$, it provides the amount by which an ASTER Level-1B image is rotated to or from True North. It is therefore, positive and clock-wise for descending orbits, and negative and counter clock-wise for ascending orbits. This field is present in:

- ASTER Level-1B data sets processed at the Ground Data System (GDS), Japan using version 4.0 (and higher versions) of the Level-1 algorithm, and available from the LP-DAAC in Sioux Falls, SD.
- ASTER Level-2 products produced at the LP-DAAC, in Sioux Falls, SD.

In the case of ASTER Level-1 data produced prior to the implementation of algorithm version 4.0 (before May 2001), `MapOrientationAngle` is named `SceneOrientationAngle` (in the hdf metadata), and is measured as the angle from the path-oriented image to north-up. **If you are using an ASTER Level-1B processed prior to May 2001, using an algorithm version that is less than 4.0 (referred to as `PGEVERSION` in the hdf metadata), it is important to bear in mind that the `SceneOrientationAngle` values have reverse signs.**

There are two collection versions of the routinely produced ASTER Level-1 data sets available from the LP-DAAC (Versions 002 and 003). Typically, all data sets produced with algorithm version 4.0 (and higher versions) are available in the version 003 collection while data sets produced with algorithm versions lower than 4.0 are available in the version 002 collection.

The upper-left for an ASTER scene is relative to the orbital path of the Terra satellite (the diagram below (Figure 30) relates to Landsat-7 satellite but is also useful in visualizing the orbital paths of the Terra satellite platform).

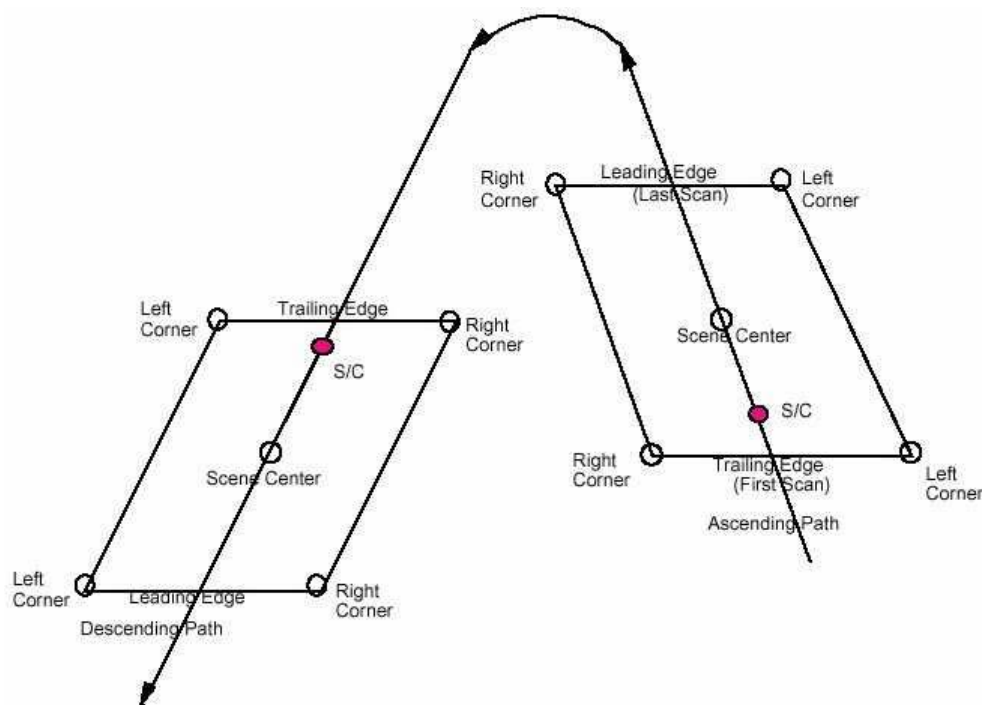

Figure 30: Ascending and Descending Orbital Paths.

Source: Landsat 7 Processing System (LPS) Output Files Data Format Control Book, 510-3FCD/0195, July 1998

12.4.4 Geometric Correction Table

ASTER HDF metadata contains Geometric Correction Tables (GCTs) for each telescope, including the VNIR 3B band. These GCTs are arrays of pixel/line locations and their corresponding geographic coordinates. It is important to remember that for ASTER Level-1A and Level-1B data, the GCTs are in geocentric coordinates. For all ASTER Level-2 products, the GCTs are in geodetic coordinates.

GCTs contain information that are internal to the swath data structures. As part of the geometric correction, each scene is divided into block units, and the processing of the scene is done block by block in both the along-track and cross-track directions. The values for the lattice points constitute coordinates for each lattice block located by their center pixel and their corresponding latitudes and longitudes in geocentric coordinates.

The stepping in each dimension is specified in the structural metadata of the swath. The interval spacing for the GCT begins with (0, 0), and increments by values contained in the HDF metadata fields named ImageLine and ImagePixel.

Example of a VNIR Swath stepping:

VNIR Structural metadata is in a global attribute called StructMetadata.0



ASTER Users Handbook

OBJECT = DimensionMap_1
 GeoDimension = GeoTrack
 DataDimension = ImageLine
 Offset = 0
 Increment = 420
 END_OBJECT = DimensionMap_1
 OBJECT = DimensionMap_2
 GeoDimension = GeoXtrack
 DataDimension = ImagePixel
 Offset = 0
 Increment = 498
 END_OBJECT = DimensionMap_2

The stepping cross-track is 498 pixels and the along-track stepping is 420 pixels. Both Offsets are zero. The 11 x 11 arrays give the locations for the following pixels (using 0 for smallest index):

| | |
|---------------------------------------|--------------|
| (line, sample) = (0,0), (0, 498), ... | (0, 4980) |
| (420,0), (420, 498) ... | (420, 4980) |
| (840,0) (840, 498) ... | (840, 4980) |
| · | · |
| · | · |
| (3780,0), (3780,498) ... | (3780,4980) |
| (4200,0) ... | (4200, 4980) |

ASTER Level-1B and ASTER Level-2 GCT values, and the SceneFourCorners values are both generated from the Level-1B. The SceneFourCorners upper-left matches the GCT (0, 0) out to 6 decimal places. The GCT coordinates are more precise, extending out to 12 or more decimal places. There should be no significant difference between the positional accuracy of the data using either the GCT values as ground control, or the SceneFourCorners upper-left and MapOrientationAngle to orient either the ASTER Level-1B data or Level-2 products.

The equation to convert the swath-based geocentric coordinates to geodetic coordinates is:

$$\mathbf{Geodetic} = \mathbf{Arctan} [(\mathbf{tan} (\mathbf{Latitude})) / \mathbf{0.99330562}]$$

This equation is for the WGS 84 datum only. Geocentric longitudes do not need to be converted to geodetic since they both are the same and they also share the same reference meridian and axis.



12.4.5 Geodetic versus Geocentric Coordinates

Geodetic coordinates specify a location on the Earth's oblate (non-spherical) surface. Geodetic latitude is defined as the angle between the equatorial plane and a line normal to the surface at that location. Geodetic longitude is the angular distance between the location's meridian and the Greenwich meridian.

Geocentric coordinates relate to a reference system where the origin is the center of the Earth. Geocentric latitude is defined by the angle between the equatorial plane and a line from the local position to the intersection of the axis of rotation with the equatorial plane. Geodetic longitude and geocentric longitude are the same because they share the same reference meridian and axis.



13.0. Frequently-Asked Questions

This section provides a representative sample of frequently-asked questions (FAQs) from users relating to various aspects of ASTER that were received both at JPL and LP-DAAC since ASTER data were made publicly available in November of 2000. These FAQs have been broadly categorized in 10 groups:

| | |
|-------|-----------------------------------|
| 13.1 | General ASTER |
| 13.2 | ASTER Instrument |
| 13.3 | ASTER Level-1 Data |
| 13.4 | Acquiring and Ordering ASTER Data |
| 13.5 | ASTER Metadata |
| 13.6 | ASTER Higher-Level Products |
| 13.7 | ASTER Expedited Data Sets |
| 13.8 | ASTER-Related Algorithms |
| 13.9 | ASTER Documentation |
| 13.10 | HDF-EOS Data Format |

13.1 General ASTER

Could you give a brief description of ASTER and its sensor systems?

The Advanced Spaceborne Thermal Emission and Reflection Radiometer (ASTER) is one of 5 instruments aboard the Terra platform that was launched in December, 1999. ASTER was built by a consortium of Japanese government, industry, and research groups. It has three spectral bands in the visible near-infrared (VNIR), six bands in the short-wave infrared (SWIR), and five bands in the thermal infrared (TIR) regions, with 15, 30, and 90 meters ground resolution respectively. This combination of wide spectral coverage and high spatial resolution allows ASTER to discriminate amongst a large variety of surface materials, ideal for geological studies. The VNIR subsystem is specifically endowed with a backward-viewing telescope for high-resolution stereoscopic observation in the along-track direction. The ASTER instrument is unique in two respects: one, it provides multispectral thermal infrared data of high spatial resolution, and also the highest spatial resolution surface spectral reflectance, temperature and emissivity data of all the Terra instrument sensor systems; and two, because of its limited duty cycle, data are acquired to fulfill on-demand data acquisition requests. The ASTER data products include relative spectral reflectance and emissivity, surface radiance, temperature, reflectance and emissivity, brightness temperature-at-sensor, and digital elevation models. ASTER data are expected to contribute to a wide array of application areas including, geology and soils, vegetation and ecosystem dynamics, hazards monitoring (volcanoes, wildfires, floods, landslides, and coastal erosion), land surface climatology, hydrology, and land cover change.

Additional details regarding the instrument, data products etc. can be accessed from:

<http://asterweb.jpl.nasa.gov/default.htm>

What are the sizes of ASTER pixels?



ASTER provides data at 3 different spatial resolutions (pixel sizes). The resolutions are 15 m, 30 m and 90 m for the visible-near-infrared, shortwave infrared and thermal infrared respectively. For more information check the ASTER web page (<http://asterweb.jpl.nasa.gov/>).

Is there an index map of all the ASTER images that are available?

There are some on-line tools that you can use to find the breadth of ASTER coverage.

The ASTER DAR (Data Acquisition Request) Tool at <http://e0ins02u.ecs.nasa.gov:10400/> allows one to run a search for an area of interest to see if images have been collected. There is a map that will show the footprints of each image and the outline of the area of interest. The DAR Tool also shows the time frame in which scenes are scheduled to be acquired. Please read the Getting Started and Limitations Documents before launching the tool.

Another tool you can use is available from the ASTER GDS (Ground Data System) site at <http://imsweb.aster.ersdac.or.jp/ims/cgi-bin/dprSearchMapByMenu.pl> Here, you will also need to enter your area of interest (or do a global search) to find images that have been acquired. There is a map that shows coverage, and there also are browse images.

The most conclusive results can be derived by searching the EOS Data Gateway (EDG) at <http://edcimswww.cr.usgs.gov/pub/imswelcome/>

You can search for all the archived and available images from the EROS Data Center's LP-DAAC archives. There is no end-to-end coverage map but the EDG will return a footprint of your search results. Individual browse images are available for most of the acquired scenes. Individual footprints of selected granules are also returned upon querying. Please read the tutorial for more information (<http://edcdaac.usgs.gov/tutorial/>)

13.2 ASTER Instrument

Where do I find information about the ASTER instrument characteristics, e.g. the signal to noise?

The ASTER instrument characteristics including the signal to noise are given on the ASTER **webpage** under instrument.

13.3 ASTER Level-1 Data

What is an ASTER Level-1A dataset?

An ASTER Level-1A dataset contains reconstructed, unprocessed instrument digital data derived from the telemetry streams of the 3 telescopes: Visible Near Infrared (VNIR), Shortwave Infrared (SWIR), & Thermal Infrared (TIR). Data derived from each of these telescopes or sensors are at three different ground resolutions: VNIR at 15 m, SWIR at 30 m, and TIR at 90 m. These depacketized, demultiplexed, and realigned instrument image data have their geometric



correction coefficients and radiometric calibration coefficients calculated and appended but not applied.

Level-1A datasets also include corrections for the SWIR parallax, and intra- and inter-telescope registration information. ASTER Level-1A data is produced at the Ground Data System (GDS) in Tokyo, Japan, and sent to the EROS Data Center's (EDC) Distributed Active Archive Center (DAAC) for archiving, distribution, and higher-level processing.

Does ASTER Level-1A dataset have associated browse images?

There are 3 separate browse files (one each for VNIR, SWIR and TIR) along with an ASTER Level-1A dataset that can interactively be viewed (through the View Image button) and/or ordered via the EOS Data Gateway (EDG). On occasions there may only be data derived from one or two sensor(s). At such times there will not be all three browse images. Each browse file can be ordered via the EDG. The browse files can also be downloaded as a UNIX tar file.

Can you provide details (format, image dimensions) of the Level-1A browse files?

The ASTER Level-1 Browse Data Product contains 1-scene of image data generated based on the Level-1A data with similar radiometric corrections and mis-registration corrections applied to Level-1B data. All image data (VNIR, SWIR, TIR) are 24-bit JPEG compressed images stored in an HDF file in RIS24 objects. Refer to Table 2 in this Handbook, which provides the main characteristics of the Level-1A browse images.

What is an ASTER Level-1B dataset?

The ASTER Level-1B product contains radiometrically calibrated and geometrically co-registered data for all the channels acquired previously through the telemetry streams of the 3 different telescopes in Level-1A. This product is created by applying the radiometric calibration and geometric correction coefficients to the Level-1A data. Both intra-telescope and inter-telescope registration corrections have also been applied relative to the reference band of each sub-system. The Level-1B product offers the same number of bands at the same resolution as the Level-1A product. Level-1B data are required as the input for generating higher level-2 geophysical products. On the EDG, the View Image button allows the L1B granule to map back to the L1A's browse (assuming the parent L1A granule exists in the inventory). These Level-1B data are produced at the Ground Data System (GDS) in Tokyo, Japan, and sent to the EROS Data Center's (EDC) Distributed Active Archive Center (DAAC) for archiving, distribution, and higher-level processing.

Does ASTER Level-1B dataset have associated browse images?

There are no browse images produced from ASTER Level-1B datasets. The "View Image" button on the EDG for an ASTER L1B dataset (when active) maps back to an ASTER Level-1A browse. The same caveats that apply to Level-1A browse apply to Level-1B browse also.

Why is the "View Image" button for my ASTER Level-1B dataset inactive?



There are a few occasions when we do not receive the parent Level-1A granule or receive them late from GDS, Japan. Under such circumstances, the Level-1B will not be mappable to its parent Level-1A granule, and hence the inactive “View Image” button.

What are the average sizes of ASTER L1A and L1B data sets, and how are the data quantized?

The ASTER Level-1A data set contains image and ancillary data from all 3 sensors (assuming data from all three sensors were collected). The average sizes of these 14 channels or bands for L1A and L1B data sets are:

| Sensor/Telescope | ASTER L1A (Megabytes) | ASTER L1B (Megabytes) |
|---------------------------|-----------------------|-----------------------|
| VNIR (Bands 1, 2, 3N) | 51,660,000 | 62,748,000 |
| VNIR (Band 3B) | 23,000,000 | 22,908,000 |
| SWIR (Bands 4 through 9) | 25,804,800 | 31,374,000 |
| TIR (Bands 10 through 14) | 4,900,000 | 5,810,000 |
| Total | 107 Megabytes | 118 Megabytes |

VNIR and SWIR are 8-bit unsigned integer data, and TIR are 16-bit unsigned integer data.

What are the image dimensions of an ASTER L1A and L1B data set?

The image dimensions for an ASTER L1A and L1B data set are:

| Sensor/Telescope | ASTER L1A | ASTER L1B |
|----------------------------|--------------------------|--------------------------|
| VNIR: (Bands 1, 2, 3N) | 4200 rows x 4100 columns | 4200 rows x 4980 columns |
| VNIR: (Band 3B) | 4600 rows x 5400 columns | 4600 rows x 4980 columns |
| SWIR: (Bands 4 through 9) | 2100 rows x 2048 columns | 2100 rows x 2490 columns |
| TIR: (Bands 10 through 14) | 700 rows x 700 columns | 700 rows x 830 columns |

What are the areal dimensions of an ASTER image?

The nominal size of an ASTER Level-1 scene is about 60 km by 60 km. This is only slightly larger for the VNIR 3B image (which is used in generating stereoscopic images for producing DEMs).

Could you help me understand the file naming convention of an ASTER Level-1 data set?

The ASTER Level-1 File naming convention (from GDS) breaks down as follows:

pg-PR1B0000-2001021503_007_001

PR1B0000: Processing level

2001: Production date (year)

02: Production date (month)



15: Production date (day)

03: Sequence number of production plan for that particular day

007: Processing strip number

001: Sequence number in the processing strip

The ASTER Level-1 file is distributed without a **.hdf** suffix. It is a good idea to rename your file with it: **pg-PR1B0000-2001021503_007_001.hdf**. This will enable your image processing software to identify this particular format.

How do I interpret ASTER Level-1 file names and match them with granule/scene IDs?

An ASTER Level-1 granule-ID on the EDG is specified: SC:AST_L1A.002:2004799662

Following your order, an ASTER Level-1 granule is distributed with a file name like:

pg-PR1A0000-2001111802_042_013 (This is the file naming convention from GDS) along with an ECS-generated metadata file: pg-PR1A0000-2001111802_042_013.met

The information used to match the file to the granule/scene ID is the date and time found in the EDG-returned results and the embedded metadata file. The embedded file exists as part of the header within the image file. Some of the commercial and public domain software allow you to open this information and save it as an ASCII file.

The date and time on the EDG-returned results for scene SC:AST_L1A.002:2004799662 is 05 Nov 2001, 10:37:24, which is the acquisition date and time. However, the values in the distributed file name (pg-PR1A0000-2001111802_042_013) are the date and time that the scene was produced.

To re-iterate from the earlier question, the details are to be interpreted thus:

PR1A0000: Processing level

2001: Production date (year)

11: Production date (month)

18: Production date (day)

02: Sequence number of production plan for that particular day

042: Processing strip number

013: Sequence number in the processing strip

To match a file name with an image that is in our archive, you can use the GDS ID found within the productmetadata.0 file (hidden file) under the object attribute IDOFASTERGSDSDATAGRANULE

For example: ASTL1A 0111051037240111180891 (from scene SC:AST_L1A.002:2004799662/ file pg-PR1A0000-2001111802_042_013) can be interpreted:

Format:

‘ASTL1A YYMMDDHHMMSSyymmddNNNN’

where,



YYMMDD: observation date
 HHMMSS: observation time
 yymmdd: the data granule generation date
 NNNN: the data granule sequential No. per day

So ASTL1A 0111051037240111180891 translates to:
 011105: observation date
 103724: observation time
 011118: the data granule generation date
 0891: the data granule sequential No. per day

I searched and found a Level-1A dataset for my area of interest, but I don't see its corresponding Level-1B dataset for the same area?

There is always going to be more L1A than L1B data because not all L1A data are processed to L1B at the GDS in Japan. Approximately one-third of the data are processed from 1A to 1B based on cloud cover and quality. Prior to May 2001, the cloud cover assessment algorithm at GDS was over-estimating the cloud cover, resulting in fewer Level-1B products being created and shipped to the LP-DAAC for archival and higher-level processing. Requests for processing L1A to L1B can be submitted to GDS directly at a cost of \$ 100.00 per scene. If you are interested in submitting such a request to GDS, **click here** for more details.

I searched and found a Level-1B dataset for my area of interest, but I don't see its corresponding Level-1A dataset for the same area?

There are occasions when we do not receive the L1A for the corresponding L1B from GDS. This is mainly because we simply did not receive the parent L1A granule for the L1B (from GDS, Japan) that you found. Do write to us about it and we will investigate.

How do I know that a certain L1B was derived from a particular L1A granule?

The indication that a L1B was derived from a particular L1A is the data acquisition time (Start and Stop Time), which will be identical for both of them. When the list of granules is returned on the EDG, the Start Time and Stop Time columns display the data acquisition times. This reports the hour, minutes, and seconds (example: **19:11:34**). If you click on the Granule Attributes button for that granule, it will take you to a series of metadata information. In the block entitled Additional Attribute Information, there is a field called **SingleDateTime**, which gives you the exact time of data acquisition, including the milliseconds:

Example:
SingleDateTime TimeOfDay = 19:11:34.773000
CalendarDate = 2000-08-31

How do I order an ASTER Level-1 dataset?



ASTER Level-1 (L1A and L1B) datasets can be ordered through the EOS Data Gateway (EDG). There is a tutorial for new users who require more help with understanding how the EDG works: <http://edcdaac.usgs.gov/tutorial>

The browse image for a L1A data set that I searched for, displayed as a black box. Why is that?

It is likely that this granule was a night-time acquisition, and only the Shortwave Infrared (SWIR) and Thermal Infrared (TIR) sensors are likely to have acquired data during this time frame. The browse shows up as a blank image because there is no reflected energy being sensed in the SWIR bands unless there is a feature emitting energy at a high level. Please click on the second browse icon that relates to the thermal infrared (TIR) browse to consider whether these data would be of use.

I am interested in thermal images acquired at night. How do I search for such acquisitions?

Night-time acquisitions are, in theory, acquired between sunset and sunrise. You can search for such acquisitions by defining a temporal window for instance, 11:00 pm to 2:00 am in GMT. It is important to bear in mind that these searches can only work for a 24-hour period.

The ASTER 1A data contain both geometric (e.g. band offsets) and radiometric artifacts (e.g. striping). Is there any software I can get to remove these?

ASTER 1A data are the raw data with the radiometric and geometric correction coefficients appended but not applied. They are applied in the 1B product. You should order the 1B product. The software for processing the 1A to 1B data presently is used at the LP-DAAC only to produce ASTER Expedited data.

Are ASTER 1B images radiometrically calibrated?

Yes, ASTER 1B images are radiometrically calibrated, however, in order to keep image sizes small they are rescaled in the byte and halfword ranges (the VNIR and SWIR are in byte) and the TIR are in halfword (2 byte). In order to scale the data to the correct range you need to apply the coefficients listed earlier in this document.

Are ASTER 1B images always processed to the same version?

No - there have been multiple updates to the software and if you downloaded the ASTER data over your site a few months ago there may now be a new version of the same scene. You should always try and get the latest version since each new version improves the data, e.g. the registration between bands. This is because our understanding of how the instrument behaves in space has improved over time. You get the latest version by ordering the data from the most recent collection for a given product from the LP-DAAC archives. In some cases only an older version may be available. Presently, there are two collection versions of the routinely produced ASTER Level-1 data sets available from the LP-DAAC (Versions 002 and 003). Typically, all



data sets produced with algorithm version 4.0 (and higher versions) are available in the version 003 collection while data sets produced with algorithm versions lower than 4.0 are available in the version 002 collection.

Is the ASTER L1B product terrain-corrected?

The ASTER L1B product is not terrain-corrected so there may be some vertical scaling anomalies.

13.4 Acquiring and Ordering ASTER Data

How do I find out if ASTER data are available over my study area and if they are not how do I get them acquired?

In order to find out if ASTER data are available, search the ASTER archives at the EROS Data Center's Land Processes DAAC through the **EDG**. All acquired and processed ASTER data are archived and distributed from here (<http://edcimswww.cr.usgs.gov/pub/imswelcome/>). You may enter as Guest for search purposes. There will also be information for ordering data. If your Area of Interest has not been collected, you may submit a Data Acquisition Request proposal for evaluation. Once approved the user is granted privileges for submitting a limited number of observation requests. These requests go directly into the scheduling database. The following URL will direct you to the DAR tool users request form.

<http://asterweb.jpl.nasa.gov/gettingdata/authorization/default.htm>. Read through the short three page directions and proceed to enter your proposal request. Further instructions will follow once the proposal has been submitted for evaluation.

How much do ASTER data cost?

Currently ASTER Level-1A and 1B data are available from the LP-DAAC at \$55 per scene. Higher-level data products are free. (<http://edcimswww.cr.usgs.gov/pub/imswelcome/>).

How do I find out when ASTER will be over my site?

There is a web-based tool available at:

<http://earthobservatory.nasa.gov/MissionControl/overpass.html> that can be used for overpass predictions. Using the tool: The Spacecraft designation should be "TERRA". Enter the overpass criteria then execute the prediction using the predict button. On the results page, look at the Peak time (UTC) for the given date with Peak Elevation angles greater than 81.5 deg. and with "Vis" field 'DDD' for Day scenes and 'NNN' for night scenes. If the Peak Elevation is less than 81.5 deg, the target is NOT in the instruments field of view for that overpass on that day. ASTER can acquire data from the VNIR telescope more frequently by pointing.

Are ASTER data acquired over every location every 16 days?

No, although ASTER can acquire data over the same location every 16 days, its limited duty cycle prevents it from acquiring all locations every 16 days. If you want data for a particular



overpass then you should get in touch with the ASTER team to find out how to submit a request to make sure the instrument is turned on over your site on that particular 16-day cycle. The ASTER Science Support Scheduling group (SSSG) can be contacted via the ASTER web site: <http://asterweb.jpl.nasa.gov>

Does the EDC Catalogue contain all the ASTER scenes?

Yes, the EDC catalogue contains all the ASTER scenes, searching on Level-1A data searches all ASTER data acquired. It typically takes 4-6 weeks after acquisition for a scene to reach the LP-DAAC.

Can I order a mosaic of several ASTER scenes?

No ASTER data are only available as single scenes.

I submitted a proposal to have ASTER data acquired over my area. What happens next?

When a proposal is submitted, there is an automated confirmation response sent from the server database. If you do not receive the email notification you will need to resubmit the proposal again. After proper acceptance into the database, it has been taking eight to twelve weeks for complete evaluation and processing. We are actively working towards reducing the cycle time response to less than six weeks. We do appreciate everyone's patience during this transition.

I submitted a Data Acquisition Request (DAR) to have ASTER acquire data over my site. Where do I go to find out whether the DAR was successful?

The DAR tool is capable of indicating acquisition status but does not include any cloud cover ratings. If the status of a DAR is said to have 'failed' it generally means that there was no acquisition made before the Lifetime of the DAR expired. Acquisitions are determined by very complex scheduling algorithms. Delivery of the acquired data sets is usually between three and four weeks after acquisition. On occasion, the process can be completed within two weeks of an acquisition but may require special operator handling.

13.5 ASTER Metadata

What is an HDF metadata file and how can I access it?

The HDF metadata file is the information that is embedded within the header of the Level-1 hdf file. We have chosen to call it "the embedded HDF metadata" to discriminate it from the ".met" file produced externally by ECS. The embedded HDF metadata are written in ODL (Object Description Language), an ASCII-based "parameter = value" format, and contains a number of attributes relating to the Level-1 dataset. How these are viewed depends on the image-processing package being used to open the Level-1 dataset. If you have the HDF libraries set up to use the basic HDF tools available from the National Center for Supercomputing Applications (NCSA), you can use the "ncdump" utility to capture the header of the hdf file that contains the same information as the HDF metadata. The HDF metadata file broadly contains 8 attribute



groups with a number of specific attributes in each of them. These groups and the attributes are listed below: See further below for details on each of them.

- Attribute 1: HDFEOS Version
- Attribute 2: StructMetadata.0
- Attribute 3: ProductMetadata.0
- Attribute 4: ProductMetadata.1
- Attribute 5: ProductMetadata.v
- Attribute 6: ProductMetadata.s
- Attribute 7: ProductMetadata.t
- Attribute 8: CoreMetadata.0

What is an ECS metadata (.met) file and how can I access it?

The ECS metadata file is the external .met file that is delivered to the user along with the Level-1 dataset. We have chosen to call it “ECS metadata” only for convenience and to discriminate it from the embedded HDF metadata file. It is written in ODL (Object Description Language), an ASCII-based “parameter = value” format, and contains a number of attributes relating to the Level-1 dataset. The .met file provides a subset of the hdf metadata. It contains 3 broad groups of information: INVENTORYMETADATA, COLLECTIONMETADATA, and ARCHIVEMETADATA.

What is the difference between the HDF & ECS metadata files?

There are both similarities and differences between the HDF & ECS metadata files. The HDF metadata that is generated when the Level-1 data is produced in GDS, Japan is written as part of the HDF file. It contains 8 attribute groups with a number of specific attributes in each of them. These groups and the attributes contained in them are broadly summarized below. The reference to *ASTER Level-1A* and *1B* in brackets indicate at which level of the data set’s HDF metadata, the information is present:

Attribute # 1: HDFEOS Version

HDFEOS_V2.6 (*ASTER Level-1A & 1B*)

Attribute #2: StructMetadata.0

SwathStructure

VNIR_Bands 1 through 3B (*ASTER Level-1A*)

VNIR_Swath (*ASTER Level-1B*)

SWIR_Bands 4 through 9 (*ASTER Level-1A*)

SWIR_Swath (*ASTER Level-1B*)

TIR_Bands 10 through 14 (*ASTER Level-1A*)

TIR_Swath (*ASTER Level-1B*)

Dimension (*ASTER Level-1A & 1B*)

GeoTrack

GeoXTrack

ImageLine



- ImagePixel
- DimensionMap (*ASTER Level-1A & 1B*)
 - Geo Dimension
 - Data Dimension
 - Offset
 - Increment
- GeoField (*ASTER Level-1A & 1B*)
 - Latitude
 - Longitude
- DataField (*ASTER Level-1A & 1B*)

Attribute #3: ProductMetadata.0

- ASTERGenericMetadata (*ASTER Level-1A & 1B*)
- IDofASTERGDSDDataGranule (*ASTER Level-1A & 1B*)
 - ReceivingCenter
 - ProcessingCenter
- PointingAngles (*ASTER Level-1A & 1B*)
 - SensorName
 - PointingAngle
 - SettingTimeofPointing
- GainInformation (*ASTER Level-1A & 1B*)
 - GainSettings (Bands 1 – 9)
- CalibrationInformation (*ASTER Level-1A & 1B*)
 - GeometricDbVersion
 - RadiometricDbVersion
 - CoarseDEMVersion
- DataQuality (*ASTER Level-1A & 1B*)
 - CloudCoverage
 - SceneCloudCoverage
 - QuadCloudCoverage
- SourceDataProduct (*ASTER Level-1A & 1B*)
- ObservationMode (*ASTER Level-1A & 1B*)
- ProcessedBands (*ASTER Level-1A & 1B*)
- SceneInformation (*ASTER Level-1A & 1B*)
 - ASTERSceneID
 - OrbitNumber
 - RecurrentCycleNumber
 - FlyingDirection
 - SolarDirection
 - SpatialResolution
- SceneFourCorners (*ASTER Level-1A & 1B*)
 - UpperLeft
 - UpperRight
 - LowerLeft
 - LowerRight
- SceneCenter (*ASTER Level-1A & 1B*)



SceneOrientationAngle (*ASTER Level-1A & 1B*)

Attribute #4: ProductMetadata.1

GDSGenericMetadata (*ASTER Level-1A & 1B*)

SensorShortName

IDofASTERGDSDDataBrowse

Attribute #5: ProductMetadata.v

ProductSpecificMetadata-VNIR

ExtractionfromL01 (*ASTER Level-1A*)

RelativeScanCount (First & Last)

ScanStartTime (First & Last)

PDSID (1 & 2)

ImageDataInformation for VNIR 1, 2, 3N, 3B (*ASTER Level-1A & 1B*)

NumberOfPixels

NumberOfLines

BytesperPixel

GeometricCorrection (*ASTER Level-1A*)

Number of Lattice Points in Along-Track Direction

Number of Lattice Points in Cross-Track Direction

Distance Between 2 Neighboring Lattice Points in Along-Track Direction

Distance Between 2 Neighboring Lattice Points in Cross-Track Direction

RadiometricCorrection (*ASTER Level-1A*)

Number of Detectors

Number of Parameters

DataQuality

Number of Bad Pixels

Number of Bad Pixels due to Damaged Detectors

Number of Elements of List of Bad Pixels

UnitConversionCoefficients (*ASTER Level-1B*)

Inclination

Offset

ConvertedUnit

DeStripeParameter (*ASTER Level-1B*)

NumberOfParameters

ImageStatistics (*ASTER Level-1B*)

MinValue

MaxValue

MeanValue

StdDeviation

ProcessingParameters (*ASTER Level-1B*)

Correction of Intertelescope Error (SWIR & TIR)

Correction of the SWIR Parallax Error

Resampling Method

Zone Code

Map Projection Method



Projection Parameters

Attribute #6: ProductMetadata.s

ProductSpecificMetadata-SWIR

ExtractionfromL01 (*ASTER Level-1A*)

RelativeScanCount (First & Last)

ScanStartTime (First & Last)

PDSID (1 & 2)

ImageDataInformation for SWIR 4, 5, 6, 7, 8, 9 (*ASTER Level-1A & 1B*)

NumberOfPixels

NumberOfLines

BytesperPixel

GeometricCorrection (*ASTER Level-1A*)

Number of Lattice Points in Along-Track Direction

Number of Lattice Points in Cross-Track Direction

Distance Between 2 Neighboring Lattice Points in Along-Track Direction

Distance Between 2 Neighboring Lattice Points in Cross-Track Direction

RadiometricCorrection (*ASTER Level-1A*)

Number of Detectors

Number of Parameters

DataQuality (*ASTER Level-1A*)

Number of Missing Pixels

Number of Bad Pixels due to Damaged Detectors

Number of Elements of List of Bad Pixels

UnitConversionCoefficients (*ASTER Level-1B*)

Inclination

Offset

ConvertedUnit

DeStripeParameter (*ASTER Level-1B*)

NumberOfParameters

ImageStatistics (Level-1B) (*ASTER Level-1B*)

MinValue

MaxValue

MeanValue

StdDeviation

Attribute #7: ProductMetadata.t

ProductSpecificMetadata-TIR

ExtractionfromL01 (*ASTER Level-1A*)

RelativeScanCount (First & Last)

ScanStartTime (First & Last)

PDSID (1 & 2)

ImageDataInformation for TIR 10, 11, 12, 13, 14 (*ASTER Level-1A & 1B*)

NumberOfPixels

NumberOfLines

BytesperPixel



- GeometricCorrection (*ASTER Level-1A*)
 - Number of Lattice Points in Along-Track Direction
 - Number of Lattice Points in Cross-Track Direction
 - Distance Between 2 Neighboring Lattice Points in Along-Track Direction
 - Distance Between 2 Neighboring Lattice Points in Cross-Track Direction
- RadiometricCorrection (*ASTER Level-1A*)
 - Number of Detectors
 - Number of Parameters
- NumberOfBadPixels (*ASTER Level-1A & LIB*)
 - Number of Missing Pixels
 - Number of Bad Pixels due to Damaged Detectors
 - Number of Elements of List of Bad Pixels
- UnitConversionCoefficients (*ASTER Level-1A & LIB*)
 - Inclination
 - Offset
 - ConvertedUnit
- DeStripeParameter (*ASTER Level-1A & LIB*)
 - NumberOfParameter
- Level0TIRData (*ASTER Level-1A*)
 - PDSID
 - First Packet Time
 - Last Packet Time
 - Packet Counts
- L0DataType (*ASTER Level-1A*)
- L0DataQuality (*ASTER Level-1A*)
 - Sensor Group Name
 - Number of Packets
 - Percent of Missing Packets
 - Percent of Corrected Packets
- TIRRegistrationQuality (*ASTER Level-1A & LIB*)
 - Number of Measurements
 - Measurement Point Number
 - Average Offset
 - Line Direction Average Offset
 - Pixel Direction Average Offset
 - Standard Deviation Offset
 - Line Direction Average Offset
 - Pixel Direction Average Offset
 - Threshold
 - Correlation Threshold
 - Line Direction Offset Threshold
 - Pixel Direction Offset Threshold
 - Vector Offset Threshold
- TIRShortTermCalibrationInformation (*ASTER Level-1A*)
 - Blackbody Mean
 - Blackbody Standard Deviation



- Blackbody Temperature Mean
- Blackbody Temperature Standard Deviation
- Chopper Mean
- Chopper Standard Deviation
- ImageStatistics (*ASTER Level-1B*)
 - Minimum Value
 - Maximum Value
 - Mean Value
 - Standard Deviation Value
 - Mode Value
 - Median Value
- ProcessingParameters (*ASTER Level-1B*)
 - Correction of Intertelescope Error (SWIR & TIR)
 - Correction of the SWIR Parallax Error
 - Resampling Method
 - Zone Code
 - Map Projection Method
 - Projection Parameters

Attribute #8: CoreMetadata.0

- InventoryMetadata (*ASTER Level-1A & LIB*)
 - Short Name
 - Size of Data Granule (Megabytes)
 - Production Date & Time
 - Platform Short Name
 - Instrument Short Name
- BoundingRectangle
 - West Bounding Coordinate
 - North Bounding Coordinate
 - East Bounding Coordinate
 - South Bounding Coordinate
- SingleDateTime
 - Time of Day
 - Calendar Date
- Review
 - Future Review Date
 - Science Review Date
- QAStats
 - QA Percent Missing Data
 - QA Percent Out of Bounds Data
 - QA Percent Interpolated Data
- ReProcessingActual
- PGEVersion
- ProcessingLevelID
- MapProjectionName



What is User-Friendly Metadata (UFM) and how can I use it to make my metadata file friendlier to use?

Since there is a large volume of metadata that is produced along with ASTER Level-1 datasets, it is not always practical to print the entire metadata file which can run into many pages. User Friendly Metadata (UFM) is a utility that helps condense and reformat your metadata file into a more usable size. It outputs the metadata to a hypertext markup language (html) file that can be viewed using any web browser. It is available for all flavors of UNIX and NT platforms. It is available free of charge and can be downloaded from:

<http://hdfeos.gsfc.nasa.gov/hdfeos/SoftwareDist.html>.

On average, it condenses an ASTER L1 metadata file from 84,000 bytes to 25,000 bytes. UFM presently works only with the ECS-produced .met file.

What are G-Rings and G-Polygons?

A G-Ring (or Geometry Ring) is a closed sequence of ordered pairs of coordinates of latitude and longitude in floating point that define the boundary of the area. Latitude and longitude are specified in decimal degrees with north latitudes positive and south negative, east longitude positive and west negative. The first and last points in the set of coordinates must be the same (Figure 31).

The outer G-Ring describes the outside edge of the G-Polygon (the full coverage extent). Inner G-Rings describe any holes that may occur in the G-Polygon (areas of missing coverage within the outer ring). The GPolygon class contains the G-Ring attribute for the exclusion ring flag, which is added to each polygon definition to describe whether the polygon is an inner or outer ring of coverage.

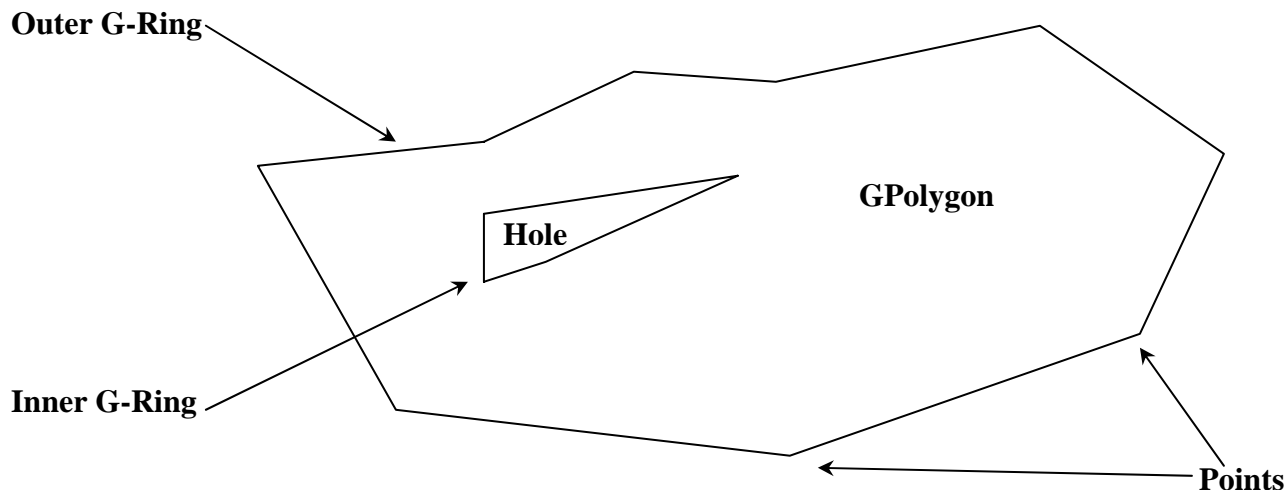

Figure 31: G-Ring and G-Polygon.

What is the difference between the GRing coordinates in the .met file versus those specified for the SCENEFOURCORNERS in the embedded metadata of the hdf file?

The GRing coordinates are populated by ECS using the SCENEFOURCORNERS information from the embedded metadata in the hdf file. The only difference is that G-Ring coordinates are rounded till the fourth decimal place while the SCENEFOURCORNERS have up to six decimal places.

Where would I find the projection information within the metadata?

This information is present under “Processing Parameters” in the product metadata for each sensor within the embedded metadata of an ASTER Level-1B granule. It includes the following attributes: Map projection, Projection parameters, Zonecode, Resampling method, Correction of inter-telescope error (for SWIR & TIR), and Correction of SWIR parallax error.

Where would I find the datum information within the metadata?

Currently, the datum information is not carried by the metadata. It is recommended that you use NAD1983 for the continental United States and WGS1984 for the rest of the world.

Are the pixel coordinates referenced by the upper left corner of the pixel or the center of that pixel?

The pixel coordinates are referenced by the center of that pixel.

Do the SCENEFOURCORNERS reference the corners of the image or those of the file?



In the case of an ASTER L1A image, the location of the four corners correspond to the area of the actual image, but in the case of an ASTER L1B image, these locations correspond to the corners of the file (in other words they include the fill or no-data area).

In general, what are the differences between geodetic & geocentric coordinates?

Geodetic coordinates specify a location on the Earth's oblate (non-spherical) surface. Geodetic latitude is defined as the angle between the equatorial plane and a line normal to the surface at that location. Geodetic longitude is the angular distance between the location's meridian and the Greenwich meridian.

Geocentric coordinates relate to a reference system where the origin is the center of the Earth. Geocentric latitude is defined by the angle between the equatorial plane and a line from the local position to the intersection of the axis of rotation with the equatorial plane.

Geodetic longitude and geocentric longitude are the same because they share the same reference meridian and axis.

Do ASTER Level-1 data conform to geodetic or geocentric coordinates?

The coordinates within an interior ASTER swath are geocentric while all the metadata are geodetic. So if you use the interior swath-based coordinate information (from the embedded metadata in the hdf file), you will need to convert it to geodetic coordinates. All the higher-level products use geodetic coordinates, both in the metadata and in the swaths.

How do I convert my geocentric coordinates in the swath to geodetic ones?

The equation to convert the swath-based geocentric coordinates to geodetic coordinates is:

$$Geodetic = \text{Arctan} [(tan (Latitude)) / 0.99330562]$$

This equation is for the WGS 84 datum only. Geocentric longitudes do not need to be converted to geodetic since they both are the same and they also share the same reference meridian and axis.

What are the 11 x 12 (VNIR), 104 x 107 (SWIR), 11 x 12 (TIR) latitude and longitude files for a Level-1A, and 11 x 11 (VNIR), 11 x 11 (SWIR), 11 x 11 (TIR) latitude and longitude files that come bundled with a Level-1B granule?

These files represent the Geometric Correction Table (GCT) and are internal to the swath data structures. Also referred to as the swath metadata, these geolocation files provide the values for the lattice points for each of the sensors. As part of the geometric correction, each scene is divided into block units, and the processing of the scene is done block by block in both the along-track and cross-track directions. The values for the lattice points constitute coordinates for each lattice block located by their center pixel and their corresponding latitudes and longitudes in geocentric coordinates. The lattice blocks and their intervals for ASTER L1A are:



| <i>Sensor (Bands)</i> | <i>Lattice Block Size</i> | <i>Number of Lattice Points</i> |
|-----------------------|---------------------------|---------------------------------|
| VNIR (1, 2, 3N) | 498 pixels x 420 lines | 11 x 13 |
| VNIR (3B) | 498 pixels x 460 lines | 11 x 13 |
| SWIR (4 through 9) | 249 pixels x 210 lines | 104 x 107 |
| TIR (10 through 14) | 83 pixels x 70 lines | 11 x 12 |

The lattice blocks and their intervals for ASTER L1B are:

| <i>Sensor (Bands)</i> | <i>Lattice Block Size</i> | <i>Number of Lattice Points</i> |
|-----------------------|---------------------------|---------------------------------|
| VNIR (1, 2, 3N) | 498 pixels x 420 lines | 11 x 11 |
| VNIR (3B) | 498 pixels x 460 lines | 11 x 11 |
| SWIR (4 through 9) | 249 pixels x 210 lines | 11 x 11 |
| TIR (10 through 14) | 83 pixels x 70 lines | 11 x 11 |

What are Product-Specific Attributes (PSAs) and how can I extend my search criteria by employing the available PSAs on the EDG

PSAs are additional metadata attributes by means of which you can refine your search criteria to filter out a specifically defined data set. Presently the available PSAs on the EOS Data Gateway include: Data Set, Data Center, Parameter, Processing Level, Sensor, Source, Band Availability, Cloud Amount, Database Identifier, Granule Details, Observation Mode, and Resampling Method. You have to individually define the attribute values for each PSA before executing your search.

Where can I find the latitude/longitude of the corner points of my ASTER scene?

The corner points of a given ASTER scene are provided in the metadata inside the HDF file. They are also given in the .met file, an ASCII text file that comes with the HDF file.

How do I find the latitude and longitude of an ASTER pixel?

The 1B file contains latitude/longitude arrays for each of the 3 instruments (VNIR, SWIR, TIR), which can be expanded to obtain the latitude/longitude of every pixel. Note the latitude values of the 1B data are in geocentric coordinates whereas the longitude values are in geodetic coordinates. You need to convert the geocentric to geodetic coordinates. For further details see the section on geometric conversion in this document.

ASTER scenes are rotated (not N-S) where do I find the amount of rotation?

The amount of rotation is specified by the MapOrientationAngle attribute in the HDF file. It should also be noted that the latitude in the Level-1B product is in geocentric coordinates whereas the longitude is in geodetic coordinates. In the case of ASTER Level-1 data produced prior to the implementation of algorithm version 4.0 (before May 2001), MapOrientationAngle is named SceneOrientationAngle (in the hdf metadata), and is measured as the angle from the path-



oriented image to north-up. **If you are using an ASTER Level-1B processed prior to May 2001, using an algorithm version that is less than 4.0 (referred to as PGEVERSION in the hdf metadata), it is important to bear in mind that the SceneOrientationAngle values have reverse signs.**

13.6 ASTER Higher-Level Products

What higher-level products are produced from an ASTER L1A data set, and where can I learn more about them?

Presently, the only higher-level products produced from an ASTER L1A data set are

- an absolute Digital Elevation Model (DEM). This product requires a requestor to submit Ground Control Points (GCPs) for their area of interest
- A relative DEM. This does not require a requestor to provide GCPs.

For more general information on the ASTER DEM product, check the product's one-pager at: <http://edcdaac.usgs.gov/aster/ast14dem.html>

For more technical details on the ASTER DEM, check its Algorithm Theoretical Basis Document (ATBD) at: http://eosps0.gsfc.nasa.gov/ftp_ATBD/REVIEW/ASTER/ATBD-AST-08/atbd-ast-08.pdf

What higher-level products are produced from an ASTER L1B data set, and where can I learn more about them?

All the higher-level ASTER geophysical products (except an absolute DEM) are produced using a L1B as its input. These products including their Long and Short names are listed below:

[There are 2 sources of information on each of these products that you would find useful:

- one, an ASTER Data Products Specification document that provides both algorithm and product descriptions besides sections on applications and constraints. These product specifications are also available in Appendix II of this Handbook.
- two, there are product one-pagers for each of these products that are available from LP-DAAC (<http://edcdaac.usgs.gov/aster/asterdataprod.html>). These provide a brief product description, data set characteristics, image dimensions, file sizes, search and ordering information, and links to algorithm, documentation etc.].

Level-2 products (the Short-Names also provide links to the LP-DAAC Product One-Pagers):

Routinely Produced at ECS-EDAAC

- | | |
|---|----------------|
| 1. ASTER Level-2 Decorrelation Stretch Product (VNIR) | AST_06V |
| 2. ASTER Level-2 Decorrelation Stretch Product (SWIR) | AST_06S |
| 3. ASTER Level-2 Decorrelation Stretch Product (TIR) | AST_06T |



Produced on-demand at ECS-EDAAC

- | | |
|---|-----------------|
| 1. ASTER On-Demand Level-2 Decorrelation Stretch Product (VNIR) | AST_06VD |
| 2. ASTER On-Demand Level-2 Decorrelation Stretch Product (SWIR) | AST_06SD |
| 3. ASTER On-Demand Level-2 Decorrelation Stretch Product (TIR) | AST_06TD |
| 4. ASTER Level-2 Brightness Temperature at the Sensor | AST_04 |
| 5. ASTER Level-2 Emissivity Product | AST_05 |
| 6. ASTER Level-2 Surface Reflectance Product (VNIR & SWIR) | AST_07 |
| 7. ASTER Level-2 Surface Kinetic Temperature Product | AST_08 |
| 8. ASTER Level-2 Surface Radiance Product (VNIR & SWIR) | AST_09 |
| 9. ASTER Level-2 Surface Radiance Product (TIR) | AST_09T |
| 10. ASTER Polar Surface & Cloud Classification | AST13POL |

Level-3 products

A. Produced on-demand at ECS-EDAAC

- | | |
|------------------------------------|-----------------|
| 1. Digital Elevation Model Product | AST14DEM |
|------------------------------------|-----------------|

You can order any of these products using the **ASTER On-Demand Gateway**.

How do I get a DEM generated from ASTER data for my area?

ASTER DEM's can be produced as an on-demand product through the EDG website. You must first search for Level-1A data, then follow the link next to the granule ID. Please note that our production rate is 1-2 DEM's per day, so there is a queue of several months.

Are the DEM's absolute or relative?

Both absolute and relative DEM's can be ordered. For absolute DEM's you need to provide a control point.

What is the difference between a Relative DEM and an Absolute DEM?

An Absolute ASTER DEM is generated by using Ground Control Points (GCP) supplied by the requestor. The software uses the GCPs to tie the DEM to known points on the ground and yields a product with real ground elevations. The Absolute DEM is geo-coded using customer-supplied Ground Control Points (GCPs).

A Relative ASTER DEM is generated by using only the satellite ephemeris data and will yield a product with ground elevations that are quite near those of an Absolute DEM. The Relative DEM is not nearly as accurate as the Absolute DEM horizontally since the Relative DEM is geo-coded using only satellite ephemeris data.

Why are some ASTER DEMs approximately 12 Mb in size and some others are approximately 25 Mb in size?



There was a change in the ASTER DEM output format from a 16-bit to a 32-bit file in late-January, 2002. Hence, all ASTER DEMs processed on or after 22 January 2002 will be approximately 25 Mb in size compared to the DEMs produced prior to that date, which are approximately 12 Mb in size.

How can I determine if the ASTER image is a good candidate for DEM production?

You can execute your search with 2 Product Specific Attributes, “Cloud Amount”, and “Band Availability” to ensure you have a suitable image with the requisite bands (3n and 3b) present. It is highly recommended that you view the browse image to verify cloud areas. The best candidate for DEM production would be cloud-free, and would have sufficient contrast in its image values. A DEM can be produced from an image with clouds, however the clouds and their dark shadows on the image will be shown as a “void area” or a “no data” area on the DEM. Both thick, and high wispy clouds will cause void areas in a DEM and will also cause data near the clouds to be inaccurate. Areas of constant tone, such as large sand areas or snowfields, may also cause failure in the resulting data.

How can I tell the difference between an Absolute and a Relative DEM on the EDG?

While viewing a list of the returned results of DEM granules on the EDG, one of the columns provides a link called “Granule Attributes.” Click on that link to view additional information on the DEM including whether it is an absolute or a relative DEM.

How do I get the surface reflectance from the ASTER 1B data?

The ASTER team provides a reflectance product that can be ordered when the 1B data are ordered. However, there are problems with crosstalk from band 5 to band 9. The problem is under investigation.

How do I get temperature and emissivity from ASTER 1B data?

The ASTER team provides a temperature and emissivity product that can be ordered when the 1B data are ordered.

13.7 ASTER Expedited Data Sets

What is an ASTER Level-1 Expedited Data Set (EDS)?

The Expedited ASTER Level-1A data set is produced with the express purpose of providing the ASTER Science Team members data of their particular interest in quick turn-around time from the moment the data are acquired. This is usually done to support on-going field calibration and validation efforts or to support emergency response to natural disasters when processed Level-1 data with minimum turn-around time would prove beneficial in initial damage or impact assessments. This data set is expected to be publicly available for a period of 30 days after which time it will be removed from the archive. This is done because the routinely processed



(Production Data Set or PDS) version of this data set will be available from Japan in due course for search and order from the LP-DAAC archives. ASTER Expedited Data Sets (EDS) serve the short-term requirements of a small group of scientists and fulfill immediate imagery needs during times of natural disasters.

How is an ASTER Level-1 Expedited Data Set different from the Production Data Set (PDS)?

The general product description details as described for the Production Data Set version of the ASTER Level-1A Data Set – Reconstructed, Unprocessed Instrument Data apply to the expedited data set with a few notable exceptions. These include:

- Stereo data is not available from the Expedited Level - 1 data set since it does not contain the VNIR 3B (aft-viewing) Band.
- TIR data quality is expected to be lower than that of the regular PDS data because short-term calibration for TIR is not available. Instead, the long-term calibration is used.
- The Inter-telescope registration quality may be lower than that of PDS. This is because regular PDS data are surrounded by 13 adjacent scenes to ensure sufficient information for inter-telescope registration. However, these 13 adjacent scenes are not transmitted via the expedited pathway, and therefore are not available.
- The geometry of L1BE scenes is slightly different than L1B because the expedited processing uses the raw spacecraft ephemeris data, and the L1B processing uses the refined (post-processed) ephemeris data.

Why are there only a few EDS granules in that collection compared to the PDSs?

The expedited data sets are produced in response to particular requirements such as on-going field calibration and validation activities carried out by a core group of scientists. It is also produced on occasion, to provide immediate imagery data that characterize natural emergency situations. Both these requirements are infrequent and satisfy certain immediate short-term needs. They are not expected to be used for analytical science-driven application purposes. That explains why these ad-hoc products are fewer in numbers. All end-users seeking to apply ASTER data are encouraged to use the Production Data Set (PDS) version of the Level-1 data available from the LP-DAAC.

13.8 ASTER-Related Algorithms

Where do I find out more about the algorithms used to process ASTER data?

The algorithms used to process ASTER data are described in the ASTER Theoretical Basis Documents (ATBD's). These can be downloaded from the ASTER web site. Refer to the next section on ASTER Documentation.



13.9 ASTER Documentation

The Product Specifications for ASTER Level-1:

<http://asterweb.jpl.nasa.gov/documents/ASTER%20Data%20Product%20Specification.pdf>

Algorithm Theoretical Basis Documents (ATBDs) are detailed documents put together by the Principal Investigator(s) for a particular product. They provide an introduction, overview, theoretical description of the algorithm, the mathematics, programming and implementation considerations, constraints, limitations and assumptions. This is the definite source of information for the serious researcher who requires a lot of background information on theory, methodology and further references.

The ATBDs for ASTER Level-1 and higher-level products can be accessed from:

| | |
|--------------------------------|--|
| ASTER Level-1 | eospspo.gsfc.nasa.gov/ftp_ATBD/REVIEW/ASTER/ATBD-AST-01/11atbd.pdf |
| Decorrelation Stretch | eospspo.gsfc.nasa.gov/ftp_ATBD/REVIEW/ASTER/ATBD-AST-06/atbd-ast-06.pdf |
| Brightness Temp. at Sensor | eospspo.gsfc.nasa.gov/ftp_ATBD/REVIEW/ASTER/ATBD-AST-02/atbd-ast-02.pdf |
| Surface Temp./Emissivity | eospspo.gsfc.nasa.gov/ftp_ATBD/REVIEW/ASTER/ATBD-AST-03/atbd-ast-03.pdf |
| Surface Radiance & Reflectance | eospspo.gsfc.nasa.gov/ftp_ATBD/REVIEW/ASTER/ATBD-AST-04/atbd-ast-04.pdf |
| Surface Radiance - TIR | eospspo.gsfc.nasa.gov/ftp_ATBD/REVIEW/ASTER/ATBD-AST-05/atbd-ast-05.pdf |
| Polar Surface Classification | eospspo.gsfc.nasa.gov/ftp_ATBD/REVIEW/ASTER/ATBD-AST-07/atbd-ast-07.pdf |
| ASTER DEM | eospspo.gsfc.nasa.gov/ftp_ATBD/REVIEW/ASTER/ATBD-AST-08/atbd-ast-08.pdf |
| ASTER Validation Plan | eospspo.gsfc.nasa.gov/ftp_ATBD/REVIEW/ASTER/VALIDATION/val-ast-full.pdf |
| ASTER Validation Summaries | eospspo.gsfc.nasa.gov/ftp_docs/ASTER_VAL_SUM_0901.pdf |

What on-line resources are available to learn more about ASTER?

<http://asterweb.jpl.nasa.gov>

<http://www.gds.aster.ersdac.or.jp>

<http://edcdaac.usgs.gov/dataproducts.html>

<http://edcdaac.usgs.gov/asterondemand/index.html>

<http://terra.nasa.gov>

Can you give me a list of general overview articles/papers on ASTER that have thus far been published?

A. KAHLE, F. PALLUCONI, S. HOOK, V.J. REALMUTO, and G. BOTHWELL, (1991) The Advanced Spaceborne Thermal Emission and Reflectance Radiometer (ASTER). Int. J.Imaging System Tech., vol. 3, pp. 144-156.

FUJISADA, H., (1998) ASTER Level-1 Processing Algorithm. IEEE Transactions on Geoscience and Remote Sensing, Vol. 36, pp. 1101 - 1112.

FUJISADA, H., (1994) Overview of ASTER Instruments on EOS-AM1 Platform. Proceedings, SPIE, International Society for Optical Engineering, Vol. 2268, pp. 14 - 36.

YAMAGUCHI, Y., KAHLE, A., TSU, H., KAWAKAMI, T., and PNIEL, M. (1998) Overview of ASTER. IEEE Transactions on Geoscience and Remote Sensing, Vol. 36, pp. 1062 – 1071



Y. YAMAGUCHI, H. TSU,, A. KAHLE, and D.A. NICHOLS, (1994) ASTER instrument design and science objectives. Amer. Inst. Aeron. Astron., vol. 7, paper 94-0597.

Y. YAMAGUCHI, H. TSU and H. FUJISADA, (1993) Scientific basis of ASTER instrument design. In Proc. SPIE, vol. 1939, pp. 150-160.

13.10 HDF-EOS Data Format

What data format is the ASTER Level-1 dataset in, and what software can I use to access it?

ASTER data is provided in HDF-EOS format. HDF stands for Hierarchical Data Format, which was developed by the National Center for Supercomputing Applications (NCSA) at the University of Illinois at Urbana-Champaign. HDF was originally developed for handling massive arrays to support supercomputing applications. HDF-EOS is a specific implementation of HDF to handle swaths, grids, and points.

Are there any tools available for converting ASTER data into other formats, e.g. GeoTIFF so I can use them in other packages e.g. IDL/ENVI, Arc/Info, ERDAS/Imagine?

Among the commercial image processing software packages, ENVI version 3.5 (from RSI) allows you to ingest ASTER data. Other packages that handle ASTER data include Imagine version 8.5 (from ERDAS), PCI version 8.2 (from PCI Geomatics), Matlab (from MathWorks), Noesys (from RSI), and Idrisi (from Clark University). The ASTER team at JPL has developed free tools for processing ASTER data. They are available from: <http://winvicar.jpl.nasa.gov/> Refer Appendix IV for more on available public domain software.

Where can I get help on understanding more about HDF & HDF-EOS formats?

HDF, developed by NCSA, is a public domain software that is acknowledged for its portability. HDF software includes I/O libraries and tools for analyses, visualization, and data conversion. NASA decided to incorporate a specific implementation of HDF for its EOS mission-derived data sets called HDF-EOS. This includes specific data models for storage and handling of swath, grid, and point primitives. There are a number of on-line sources of information on HDF, and HDF-EOS:

- <http://hdf.ncsa.uiuc.edu>
- <http://hdf.ncsa.uiuc.edu/hdfeos.html>
- <http://hdfeos.gsfc.nasa.gov/cfdocs/hdfeos/workshop.cfm>
- <http://hdfeos.gsfc.nasa.gov/cfdocs/hdfeos/RESOURCE.html>

Appendix IV provides more information on public domain software that handle HDF-EOS and the links to access and procure them.



Appendix I: Dump of HDF Metadata in a ASTER L1B file

coremetadata.0

```

SHORTNAME= "ASTL1B"
SIZEMBDATAGRANULE= 119.185000
PRODUCTIONDATETIME= "2001-04-14T07:24:17.000Z"
PLATFORMSHORTNAME= "AM-1"
INSTRUMENTSHORTNAME= "ASTER"
WESTBOUNDINGCOORDINATE= 29.260599
NORTHBOUNDINGCOORDINATE= -4.082604
EASTBOUNDINGCOORDINATE= 30.006667
SOUTHBOUNDINGCOORDINATE= -4.741722
TIMEOFDAY= "084727306000Z"
CALENDARDATE= "20000717"
FUTUREREVIEWDATE= "20001225"
SCIENCEREVIEWDATE= "20001109"
QAPERCENTMISSINGDATA= 0.001309
QAPERCENTOUTOFBOUNSDATA= 0.001309
QAPERCENTINTERPOLATEDDATA= 0.000000
REPROCESSINGACTUAL= "not reprocessed"
PGEVERSION= "03.00R02"
PROCESSINGLEVELID= "1B"
MAPPROJECTIONNAME= "Universal Transverse Mercator"

```

productmetadata.0

```

IDOFASTERGSDATAGRANULE= "ASTL1B 0007170847270104141228"
RECEIVINGCENTER= "EDOS"
PROCESSINGCENTER= "ASTER-GDS"
SENSORNAME= "VNIR"
POINTINGANGLE= 8.578000
SETTINGTIMEOFPOINTING= "2000-07-17T08:41:54Z"
SENSORNAME= "SWIR"
POINTINGANGLE= 8.547000
SETTINGTIMEOFPOINTING= "2000-07-17T08:41:53Z"
SENSORNAME= "TIR"
POINTINGANGLE= 8.567000
SETTINGTIMEOFPOINTING= "2000-07-17T08:41:53Z"
GAIN= ("01", "HGH")
GAIN= ("02", "HGH")
GAIN= ("3N", "NOR")
GAIN= ("3B", "NOR")
GAIN= ("04", "NOR")
GAIN= ("05", "NOR")
GAIN= ("06", "NOR")
GAIN= ("07", "NOR")
GAIN= ("08", "NOR")
GAIN= ("09", "NOR")
GEOMETRICDBVERSION= ("01.02", "2000-10-25")
RADIOMETRICDBVERSION= ("01.02", "2000-11-09")
COARSEDEMVERSION= ("1.00", "1997-09-03", "This data is generated from
GTOPO30")
SCENECLLOUDCOVERAGE= 7
QUADRANTCLOUDCOVERAGE= (4, 13, 1, 11)
SOURCEDATAPRODUCT= ("ASTL1A 0007170847270103051199", "2001-03-
05T15:23:38.000Z", "PDS")

```



ASTER Users Handbook

```
ASTEROPERATIONMODE= "OBSERVATION"  
ASTEROBSERVATIONMODE= ("VNIR1", "ON")  
ASTEROBSERVATIONMODE= ("VNIR2", "ON")  
ASTEROBSERVATIONMODE= ("SWIR", "ON")  
ASTEROBSERVATIONMODE= ("TIR", "ON")  
PROCESSEDBANDS= "01023N3B0405060708091011121314"  
ASTERSCENEID= (173, 176, 7)  
ORBITNUMBER= 3087  
RECURRENTCYCLENUMBER= (14, 58)  
FLYINGDIRECTION= "DE"  
SOLARDIRECTION= (37.043010, 57.701316)  
SPATIALRESOLUTION= (15, 30, 90)  
UPPERLEFT= (-4.082604, 29.341137)  
UPPERRIGHT= (-4.178226, 30.006667)  
LOWERLEFT= (-4.646324, 29.260599)  
LOWERRIGHT= (-4.741722, 29.926708)  
SCENECENTER= (-4.412223, 29.633727)  
SCENEORIENTATIONANGLE= -8.336200
```

productmetadata.1

```
SENSORSHORTNAME= ("ASTER_VNIR", "ASTER_SWIR", "ASTER_TIR")  
IDOFASTERGSDSDATABROWSE= "ASTL1A 0007170847270103051199B"
```

productmetadata.v

```
IMAGEDATAINFORMATION1= (4980, 4200, 1)  
MINANDMAX1= (42, 255)  
MEANANDSTD1= (60.425335, 6.740928)  
MODEANDMEDIAN1= (54, 148)  
NUMBEROFBADPIXELS1= (0, 0)  
CORINTEL1= "N/A"  
CORPARA1= "N/A"  
RESMETHOD1= "CC"  
MPMETHOD1= "UTM"  
PROJECTIONPARAMETERS1= (6378137.000000, 6356752.300000, 0.999600,  
0.000000, 0.471239, 0.000000, 500000.000000, 0.000000, 0.000000, 0.000000,  
0.000000, 0.000000, 0.000000)  
UTMZONECODE1= 35  
INCL1= 0.676000  
OFFSET1= -0.676000  
CONUNIT1= "W/m2/sr/um"  
IMAGEDATAINFORMATION2= (4980, 4200, 1)  
MINANDMAX2= (25, 251)  
MEANANDSTD2= (42.124893, 12.541837)  
MODEANDMEDIAN2= (29, 138)  
NUMBEROFBADPIXELS2= (0, 0)  
CORINTEL2= "N/A"  
CORPARA2= "N/A"  
RESMETHOD2= "CC"  
MPMETHOD2= "UTM"  
PROJECTIONPARAMETERS2= (6378137.000000, 6356752.300000, 0.999600,  
0.000000, 0.471239, 0.000000, 500000.000000, 0.000000, 0.000000, 0.000000,  
0.000000, 0.000000, 0.000000)  
UTMZONECODE2= 35  
INCL2= 0.708000  
OFFSET2= -0.708000  
CONUNIT2= "W/m2/sr/um"
```



ASTER Users Handbook

```
IMAGEDATAINFORMATION3N= (4980, 4200, 1)
MINANDMAX3N= (13, 209)
MEANANDSTD3N= (40.284557, 21.741985)
MODEANDMEDIAN3N= (17, 111)
NUMBEROFBADPIXELS3N= (0, 0)
CORINTEL3N= "N/A"
CORPARA3N= "N/A"
RESMETHOD3N= "CC"
MPMETHOD3N= "UTM"
PROJECTIONPARAMETERS3N= (6378137.000000, 6356752.300000, 0.999600,
0.000000, 0.471239, 0.000000, 500000.000000, 0.000000, 0.000000, 0.000000,
0.000000, 0.000000, 0.000000)
UTMZONECODE3N= 35
INCL3N= 0.862000
OFFSET3N= -0.862000
CONUNIT3N= "W/m2/sr/um"
IMAGEDATAINFORMATION3B= (4980, 4600, 1)
MINANDMAX3B= (20, 255)
MEANANDSTD3B= (60.560661, 15.758011)
MODEANDMEDIAN3B= (55, 137)
NUMBEROFBADPIXELS3B= (0, 0)
CORINTEL3B= "N/A"
CORPARA3B= "N/A"
RESMETHOD3B= "CC"
MPMETHOD3B= "UTM"
PROJECTIONPARAMETERS3B= (6378137.000000, 6356752.300000, 0.999600,
0.000000, 0.471239, 0.000000, 500000.000000, 0.000000, 0.000000, 0.000000,
0.000000, 0.000000, 0.000000)
UTMZONECODE3B= 35
INCL3B= 0.862000
OFFSET3B= -0.862000
CONUNIT3B= "W/m2/sr/um"
```

productmetadata.s

```
IMAGEDATAINFORMATION4= (2490, 2100, 1)
MINANDMAX4= (1, 255)
MEANANDSTD4= (35.554417, 25.348192)
MODEANDMEDIAN4= (9, 128)
NUMBEROFBADPIXELS4= (0, 0)
PROCESSINGFLAG4= 1
NUMBEROFMEASUREMENTS4= 266
MEASUREMENTPOINTNUMBER4= 224
AVERAGEOFFSET4= (-2.644275, 0.863551)
STANDARDDEVIATIONOFFSET4= (0.169957, 0.155915)
THRESHOLD4= (0.700000, 8.000000, 8.000000, 72.000000)
PCTIMAGEMATCH4= 47
AVGCORRELCOEF4= 0.900000
CTHLD4= -0.020000
CORINTEL4= "Corrected Intertelescope Error"
CORPARA4= "Corrected Parallax Error"
RESMETHOD4= "CC"
MPMETHOD4= "UTM"
PROJECTIONPARAMETERS4= (6378137.000000, 6356752.300000, 0.999600,
0.000000, 0.471239, 0.000000, 500000.000000, 0.000000, 0.000000, 0.000000,
0.000000, 0.000000, 0.000000)
UTMZONECODE4= 35
INCL4= 0.217400
```



ASTER Users Handbook

```
OFFSET4= -0.217400
CONUNIT4= "W/m2/sr/um"
IMAGEDATAINFORMATION5= (2490, 2100, 1)
MINANDMAX5= (1, 255)
MEANANDSTD5= (28.290176, 19.029987)
MODEANDMEDIAN5= (8, 128)
NUMBEROFBADPIXELS5= (0, 0)
PROCESSINGFLAG5= 1
NUMBEROFMEASUREMENTS5= 266
MEASUREMENTPOINTNUMBER5= 224
AVERAGEOFFSET5= (-2.644275, 0.863551)
STANDARDDEVIATIONOFFSET5= (0.169957, 0.155915)
THRESHOLD5= (0.700000, 8.000000, 8.000000, 72.000000)
PCTIMAGEMATCH5= 47
AVGCORRELCOEF5= 0.900000
CTHLD5= -0.020000
CORINTEL5= "Corrected Intertelescope Error"
CORPARA5= "Corrected Parallax Error"
RESMETHOD5= "CC"
MPMETHOD5= "UTM"
PROJECTIONPARAMETERS5= (6378137.000000, 6356752.300000, 0.999600,
0.000000, 0.471239, 0.000000, 500000.000000, 0.000000, 0.000000, 0.000000,
0.000000, 0.000000, 0.000000)
UTMZONECODE5= 35
INCL5= 0.069600
OFFSET5= -0.069600
CONUNIT5= "W/m2/sr/um"
IMAGEDATAINFORMATION6= (2490, 2100, 1)
MINANDMAX6= (1, 255)
MEANANDSTD6= (30.005451, 20.884729)
MODEANDMEDIAN6= (8, 128)
NUMBEROFBADPIXELS6= (0, 0)
PROCESSINGFLAG6= 1
NUMBEROFMEASUREMENTS6= 266
MEASUREMENTPOINTNUMBER6= 224
AVERAGEOFFSET6= (-2.644275, 0.863551)
STANDARDDEVIATIONOFFSET6= (0.169957, 0.155915)
THRESHOLD6= (0.700000, 8.000000, 8.000000, 72.000000)
PCTIMAGEMATCH6= 47
AVGCORRELCOEF6= 0.900000
CTHLD6= -0.020000
CORINTEL6= "Corrected Intertelescope Error"
CORPARA6= "Corrected Parallax Error"
RESMETHOD6= "CC"
MPMETHOD6= "UTM"
PROJECTIONPARAMETERS6= (6378137.000000, 6356752.300000, 0.999600,
0.000000, 0.471239, 0.000000, 500000.000000, 0.000000, 0.000000, 0.000000,
0.000000, 0.000000, 0.000000)
UTMZONECODE6= 35
INCL6= 0.062500
OFFSET6= -0.062500
CONUNIT6= "W/m2/sr/um"
IMAGEDATAINFORMATION7= (2490, 2100, 1)
MINANDMAX7= (1, 255)
MEANANDSTD7= (29.039158, 19.140051)
MODEANDMEDIAN7= (8, 128)
NUMBEROFBADPIXELS7= (0, 0)
```



```

PROCESSINGFLAG7= 1
NUMBEROFMEASUREMENTS7= 266
MEASUREMENTPOINTNUMBER7= 224
AVERAGEOFFSET7= (-2.644275, 0.863551)
STANDARDDEVIATIONOFFSET7= (0.169957, 0.155915)
THRESHOLD7= (0.700000, 8.000000, 8.000000, 72.000000)
PCTIMAGEMATCH7= 47
AVGCORRELCOEF7= 0.900000
CTHLD7= -0.020000
CORINTEL7= "Corrected Intertelescope Error"
CORPARA7= "Corrected Parallax Error"
RESMETHOD7= "CC"
MPMETHOD7= "UTM"
PROJECTIONPARAMETERS7= (6378137.000000, 6356752.300000, 0.999600,
0.000000, 0.471239, 0.000000, 500000.000000, 0.000000, 0.000000, 0.000000,
0.000000, 0.000000, 0.000000)
UTMZONECODE7= 35
INCL7= 0.059700
OFFSET7= -0.059700
CONUNIT7= "W/m2/sr/um"
IMAGEDATAINFORMATION8= (2490, 2100, 1)
MINANDMAX8= (1, 255)
MEANANDSTD8= (26.660021, 18.466541)
MODEANDMEDIAN8= (7, 128)
NUMBEROFBADPIXELS8= (0, 0)
PROCESSINGFLAG8= 1
NUMBEROFMEASUREMENTS8= 266
MEASUREMENTPOINTNUMBER8= 224
AVERAGEOFFSET8= (-2.644275, 0.863551)
STANDARDDEVIATIONOFFSET8= (0.169957, 0.155915)
THRESHOLD8= (0.700000, 8.000000, 8.000000, 72.000000)
PCTIMAGEMATCH8= 47
AVGCORRELCOEF8= 0.900000
CTHLD8= -0.020000
CORINTEL8= "Corrected Intertelescope Error"
CORPARA8= "Corrected Parallax Error"
RESMETHOD8= "CC"
MPMETHOD8= "UTM"
PROJECTIONPARAMETERS8= (6378137.000000, 6356752.300000, 0.999600,
0.000000, 0.471239, 0.000000, 500000.000000, 0.000000, 0.000000, 0.000000,
0.000000, 0.000000, 0.000000)
UTMZONECODE8= 35
INCL8= 0.041700
OFFSET8= -0.041700
CONUNIT8= "W/m2/sr/um"
IMAGEDATAINFORMATION9= (2490, 2100, 1)
MINANDMAX9= (1, 255)
MEANANDSTD9= (24.954695, 15.902023)
MODEANDMEDIAN9= (8, 128)
NUMBEROFBADPIXELS9= (0, 0)
PROCESSINGFLAG9= 1
NUMBEROFMEASUREMENTS9= 266
MEASUREMENTPOINTNUMBER9= 224
AVERAGEOFFSET9= (-2.644275, 0.863551)
STANDARDDEVIATIONOFFSET9= (0.169957, 0.155915)
THRESHOLD9= (0.700000, 8.000000, 8.000000, 72.000000)
PCTIMAGEMATCH9= 47

```



ASTER Users Handbook

```
AVGCORRELCOEF9= 0.900000
CTHLD9= -0.020000
CORINTEL9= "Corrected Intertelescope Error"
CORPARA9= "Corrected Parallax Error"
RESMETHOD9= "CC"
MPMETHOD9= "UTM"
PROJECTIONPARAMETERS9= (6378137.000000, 6356752.300000, 0.999600,
0.000000, 0.471239, 0.000000, 500000.000000, 0.000000, 0.000000, 0.000000,
0.000000, 0.000000, 0.000000)
UTMZONECODE9= 35
INCL9= 0.031800
OFFSET9= -0.031800
CONUNIT9= "W/m2/sr/um"
```

productmetadata.t

```
IMAGEDATAINFORMATION10= (830, 700, 2)
MINANDMAX10= (893, 2961)
MEANANDSTD10= (1227.876587, 98.543098)
MODEANDMEDIAN10= (1151, 1927)
NUMBEROFBADPIXELS10= (0, 0)
PROCESSINGFLAG10= 0
NUMBEROFMEASUREMENTS10= 500
MEASUREMENTPOINTNUMBER10= 22
AVERAGEOFFSET10= (-1.048756, -1.079842)
STANDARDDEVIATIONOFFSET10= (0.244948, 0.116378)
THRESHOLD10= (0.700000, 3.000000, 3.000000, 12.000000)
CORINTEL10= "Corrected Intertelescope Error"
CORPARA10= "N/A"
RESMETHOD10= "CC"
MPMETHOD10= "UTM"
PROJECTIONPARAMETERS10= (6378137.000000, 6356752.300000, 0.999600,
0.000000, 0.471239, 0.000000, 500000.000000, 0.000000, 0.000000, 0.000000,
0.000000, 0.000000, 0.000000)
UTMZONECODE10= 35
INCL10= 0.006882
OFFSET10= -0.006882
CONUNIT10= "W/m2/sr/um"
IMAGEDATAINFORMATION11= (830, 700, 2)
MINANDMAX11= (984, 2936)
MEANANDSTD11= (1330.100342, 112.198586)
MODEANDMEDIAN11= (1241, 1960)
NUMBEROFBADPIXELS11= (0, 0)
PROCESSINGFLAG11= 0
NUMBEROFMEASUREMENTS11= 500
MEASUREMENTPOINTNUMBER11= 22
AVERAGEOFFSET11= (-1.048756, -1.079842)
STANDARDDEVIATIONOFFSET11= (0.244948, 0.116378)
THRESHOLD11= (0.700000, 3.000000, 3.000000, 12.000000)
CORINTEL11= "Corrected Intertelescope Error"
CORPARA11= "N/A"
RESMETHOD11= "CC"
MPMETHOD11= "UTM"
PROJECTIONPARAMETERS11= (6378137.000000, 6356752.300000, 0.999600,
0.000000, 0.471239, 0.000000, 500000.000000, 0.000000, 0.000000, 0.000000,
0.000000, 0.000000, 0.000000)
UTMZONECODE11= 35
INCL11= 0.006780
```



ASTER Users Handbook

```
OFFSET11= -0.006780
CONUNIT11= "W/m2/sr/um"
IMAGEDATAINFORMATION12= (830, 700, 2)
MINANDMAX12= (1055, 2976)
MEANANDSTD12= (1428.515503, 117.746712)
MODEANDMEDIAN12= (1336, 2015)
NUMBEROFBADPIXELS12= (0, 0)
PROCESSINGFLAG12= 0
NUMBEROFMEASUREMENTS12= 500
MEASUREMENTPOINTNUMBER12= 22
AVERAGEOFFSET12= (-1.048756, -1.079842)
STANDARDDEVIATIONOFFSET12= (0.244948, 0.116378)
THRESHOLD12= (0.700000, 3.000000, 3.000000, 12.000000)
CORINTEL12= "Corrected Intertelescope Error"
CORPARA12= "N/A"
RESMETHOD12= "CC"
MPMETHOD12= "UTM"
PROJECTIONPARAMETERS12= (6378137.000000, 6356752.300000, 0.999600,
0.000000, 0.471239, 0.000000, 500000.000000, 0.000000, 0.000000, 0.000000,
0.000000, 0.000000, 0.000000)
UTMZONECODE12= 35
INCL12= 0.006590
OFFSET12= -0.006590
CONUNIT12= "W/m2/sr/um"
IMAGEDATAINFORMATION13= (830, 700, 2)
MINANDMAX13= (1245, 2893)
MEANANDSTD13= (1689.340332, 120.362442)
MODEANDMEDIAN13= (1600, 2069)
NUMBEROFBADPIXELS13= (0, 0)
PROCESSINGFLAG13= 0
NUMBEROFMEASUREMENTS13= 500
MEASUREMENTPOINTNUMBER13= 22
AVERAGEOFFSET13= (-1.048756, -1.079842)
STANDARDDEVIATIONOFFSET13= (0.244948, 0.116378)
THRESHOLD13= (0.700000, 3.000000, 3.000000, 12.000000)
CORINTEL13= "Corrected Intertelescope Error"
CORPARA13= "N/A"
RESMETHOD13= "CC"
MPMETHOD13= "UTM"
PROJECTIONPARAMETERS13= (6378137.000000, 6356752.300000, 0.999600,
0.000000, 0.471239, 0.000000, 500000.000000, 0.000000, 0.000000, 0.000000,
0.000000, 0.000000, 0.000000)
UTMZONECODE13= 35
INCL13= 0.005693
OFFSET13= -0.005693
CONUNIT13= "W/m2/sr/um"
IMAGEDATAINFORMATION14= (830, 700, 2)
MINANDMAX14= (1297, 2835)
MEANANDSTD14= (1765.809204, 115.020287)
MODEANDMEDIAN14= (1682, 2066)
NUMBEROFBADPIXELS14= (0, 0)
PROCESSINGFLAG14= 0
NUMBEROFMEASUREMENTS14= 500
MEASUREMENTPOINTNUMBER14= 22
AVERAGEOFFSET14= (-1.048756, -1.079842)
STANDARDDEVIATIONOFFSET14= (0.244948, 0.116378)
THRESHOLD14= (0.700000, 3.000000, 3.000000, 12.000000)
```

ASTER Users Handbook



```
CORINTEL14= "Corrected Intertelescope Error"  
CORPARA14= "N/A"  
RESMETHOD14= "CC"  
MPMETHOD14= "UTM"  
PROJECTIONPARAMETERS14= (6378137.000000, 6356752.300000, 0.999600,  
0.000000, 0.471239, 0.000000, 500000.000000, 0.000000, 0.000000, 0.000000,  
0.000000, 0.000000, 0.000000)  
UTMZONECODE14= 35  
INCL14= 0.005225  
OFFSET14= -0.005225  
CONUNIT14= "W/m2/sr/um"
```



Appendix II: ASTER Higher-Level Data Products



Decorrelation Stretch

| | |
|---------------------------|-------------------------------|
| Lead Investigator: | Ron Alley |
| Short Name: | AST_06 |
| Product Level: | 2 |
| Production Mode: | Routine |
| Absolute Accuracy: | N/A |
| Relative Accuracy: | N/A |
| Horizontal Resolution: | 15, 30, and 90 m |
| Units: | None |
| Product Size (Megabytes): | 85 (VNIR), 22 (SWIR), 3 (TIR) |

Product Description

This product, which is available for each of ASTER's three telescopes, is a decorrelation stretched image of ASTER radiance data. The Decorrelation stretch is a process to enhance (in image processing parlance, "stretch") the color differences found in a color image by a method that includes the removal of the inter-channel correlation found in the input pixels; hence, the term "decorrelation stretch". The image is produced at pixel resolutions of 15 m for VNIR, 30 m for SWIR, and 90 m for TIR. Decorrelation-stretched images provide an overview that enhances spectral reflectance variations.

Algorithm Description

If one views the pixels in an ASTER scene as a set of 3-vectors, a linear transformation can be found which results in removing the correlation among the vectors in the transformed space. This is an eigenvector problem, and can be thought of as a rotation of the coordinate system of the original vector space. Within this rotated space, each component is rescaled (contrast stretched) by normalizing the variances of the eigenvectors. If processing were to stop here, the result would be a principal component image. To produce the decorrelation stretched image, the principal component image is modified by the linear transformation that rotates the vectors back into the original coordinate system.

In practice, the original transformation, the variance normalization step, and the reverse transformation are combined into a single algebraic step.

Applications

These images are used as a visual aid in reviewing the ASTER scene data and making the selection of suitable scenes for further analysis and research. In particular, a decorrelation-stretched image would show the potential user which scenes have spectral variations large enough to be useful for subsequent spectral analysis

Constraints

The decorrelation stretch algorithm is best suited to the case where the input data of all three channels have a joint distribution that is Gaussian (or near Gaussian) in form. Fortunately the



algorithm is fairly insensitive to substantial deviations from the ideal. One should be aware, though, that if the distribution of the input pixels is strongly bimodal (or multimodal), the effectiveness of the decorrelation stretch is weakened, and there will be less diversity of color in this image than in other images.

Additionally, the decorrelation stretch algorithm is a method of color enhancement that exploits whatever interchannel differences that may exist. Implicit in this technique is the assumption that the differences are real, and not noise or processing artifacts. The algorithm single-mindedly produces a color enhanced output; if noise is a major component of the scene variation, the algorithm will enhance those noise differences to produce an output that, while colorful, will be painfully noisy.



Brightness Temperature at Sensor

| | |
|---------------------------|-----------|
| Lead Investigator: | Ron Alley |
| Short Name: | AST_04 |
| Product Level: | 2 |
| Production Mode: | On-Demand |
| Absolute Accuracy: | 1-2 C |
| Relative Accuracy: | 0.3 C |
| Horizontal Resolution: | 90 m |
| Units: | Degrees C |
| Product Size (Megabytes): | ~7 |

Product Description

The body of this product is the brightness temperature for ASTER's five thermal-infrared bands (8-12 μm , bands 10-14). Brightness temperature is the apparent observed temperature, assuming a surface emissivity of 1.0 (i.e., as if the object were a blackbody). The calculations are performed starting with the radiance at sensor as input; no atmospheric correction is included for this product.

Algorithm Description

The amount of radiance that an ASTER channel will observe when viewing a source of a particular temperature is calculated in the following manner. The spectral radiance at each wavelength (to a 0.01 μm precision) is computed using the Planck function. This value is multiplied by the normalized spectral response function at that wavelength, and the results of this calculation are integrated over the range of wavelengths that have a sensor response.

The above calculation was made for each of the five ASTER TIR channels at all temperatures (to a 0.01 degree C precision) that the ASTER TIR subsystem was designed to record (200 to 370 degrees Kelvin). The result is a table of observed radiances as a function of temperature. This table was used to construct a second table, which lists temperature as a function of radiance. This second table is stored as a lookup table, to be used to generate this product.

Applications

Brightness temperature has been used to observe volcanic ash clouds, detect ice leads in the Arctic, and to identify anthropogenic and natural fires, to name a few examples. The ASTER brightness temperature will be used as an alternate to radiance in the temperature/emissivity separation algorithm to report relative cloud-top temperature because there will be no routinely available applicable atmospheric correction to enable a calculation of exact cloud-top temperature. ASTER brightness temperatures can be acquired during the day or night and over all surface types (land, water, cloud, etc.).

Constraints



The algorithm is constrained only by the fact that it requires unsaturated input radiance values. The algorithm should work on TIR data acquired during the day or night and over land, clouds, water, or anything else not hotter than about 120 degrees C or colder than about -100 degrees C.



Surface Reflectance

| | |
|---------------------------|---|
| Lead Investigator: | Kurt Thome |
| Short Name: | AST_07 |
| Product Level: | 2 |
| Production Mode: | On-Demand |
| Absolute Accuracy: | 0.01 for reflectance < 0.15 7 % for reflectance > 0.15 |
| Relative Accuracy: | 0.005 |
| Horizontal Resolution: | 15, 30 m |
| Units: | None |
| Product Size (Megabytes): | 189 (VNIR), 79 (SWIR) |

Product Description

The Level-2 surface reflectance data set (AST07) contains surface reflectance for each of the nine VNIR and SWIR bands at 15-m and 30-m resolutions, respectively. The results are obtained by applying an atmospheric correction to radiances reported by the ASTER sensor. The atmospheric correction removes effects due to changes in satellite-sun geometry and atmospheric conditions. The atmospheric correction algorithm is applied to clear-sky pixels only and the results are reported as a number between 0 and 1.

Algorithm Description

The atmospheric correction algorithm used to retrieve the surface reflectance relies on a look-up table (LUT) approach. The LUT contains forward radiative transfer calculations from a Gauss-Seidel iteration code to compute at-satellite radiance for a set of assumed surface reflectance values and a variety of atmospheric conditions. The atmospheric correction is applied by using a set of input atmospheric conditions relating to the ASTER scene of interest to select a portion of the LUT. The output of the LUT search is a set of surface reflectance/at-sensor radiance pairs. Using linear interpolation on these pairs, a radiance reported by ASTER is converted to a surface reflectance. The atmospheric conditions are defined by the aerosol size distribution (or equivalently the aerosol type), the aerosol amount, surface pressure, and the sun-satellite geometry. The aerosol information is obtained from outside sources, for example MISR, MODIS, or climatological means. The scattering phase functions of the aerosol particles in the atmosphere are assumed to scatter as mie particles using the aerosol size distribution information supplied by MISR or MODIS. The results from this method will be in reflectance units (values between 0 and 1) with an accuracy dependent upon the accuracy of input atmospheric conditions and the surface slope. The model is expected to lose accuracy in terrain with high relief due to the assumption of horizontal homogeneity made in the radiative transfer code. Also because of this assumption, the model will give less accurate results in regions where the atmosphere or surface are not horizontally homogeneous on the scale of several pixels.

Applications



Accurate atmospheric correction removes effects of changes in satellite-sun geometry and atmospheric conditions and improves surface type classification and estimates of the Earth's radiation budget, and use of ASTER data for applications such as agricultural management requires atmospheric correction.

Constraints

This description applies to the atmospheric correction method used for the solar-reflective bands only for clear-sky pixels. This algorithm requires a digital elevation model providing slope and elevation for accurate modeling of surface reflectance. The model requires total and component optical depths as input. The algorithm is computed only for daytime image data for the VNIR - SWIR bands. The algorithm begins to break down at large view angles (not applicable for ASTER) and large solar zenith angles (>75 degrees). The algorithm's accuracy also degrades somewhat in regions around the backscatter direction due to strong surface BRDF effects. Uncertainty in the results also increases in regions of atmospheric heterogeneity.



Surface Radiance – VNIR, SWIR

| | |
|---------------------------|---|
| Lead Investigator: | Kurt Thome |
| Short Name: | AST_09 |
| Product Level: | 2 |
| Production Mode: | On-Demand |
| Absolute Accuracy: | 8% for reflectance > 0.1 15% for reflectance < 0.1 |
| Relative Accuracy: | 1% |
| Horizontal Resolution: | 15, 30 m |
| Units: | $\text{W m}^{-2} \text{sr}^{-1} \mu\text{m}^{-1}$ |
| Product Size (Megabytes): | 189 (VNIR), 79 (SWIR) |

Product Description

The Level-2 surface radiance data set (AST09) contains surface radiance for each of the nine VNIR and SWIR bands at 15-m and 30-m resolutions, respectively. The results are obtained by applying an atmospheric correction to radiances reported by the ASTER sensor. The atmospheric correction removes effects due to changes in satellite-sun geometry and atmospheric conditions. The atmospheric correction algorithm is applied to clear-sky pixels only and the results are reported as a number between 0 and 1.

Algorithm Description

The atmospheric correction algorithm used to retrieve the surface radiance relies on a look-up table (LUT) approach. The LUT contains forward radiative transfer calculations from a Gauss-Seidel iteration code to compute at-satellite radiance for a set of assumed surface reflectance values and a variety of atmospheric conditions. The atmospheric correction is applied by using a set of input atmospheric conditions relating to the ASTER scene of interest to select a portion of the LUT. The output of the LUT search is a set of surface radiance/at-sensor radiance pairs. Using linear interpolation on these pairs, a radiance reported by ASTER is converted to a surface radiance. The atmospheric conditions are defined by the aerosol size distribution (or equivalently the aerosol type), the aerosol amount, surface pressure, and the sun-satellite geometry. The aerosol information is obtained from outside sources, for example MISR, MODIS, or climatological means. The scattering phase functions of the aerosol particles in the atmosphere are assumed to scatter as mie particles using the aerosol size distribution information supplied by MISR or MODIS. The accuracy of the results from this method are dependent upon the accuracy of input atmospheric conditions and the surface slope. The model is expected to lose accuracy in terrain with high relief due to the assumption of horizontal homogeneity made in the radiative transfer code. Also because of this assumption, the model will give less accurate results in regions where the atmosphere or surface are not horizontally homogeneous on the scale of several pixels.



Applications

Accurate atmospheric correction removes effects of changes in satellite-sun geometry and atmospheric conditions and improves surface type classification and estimates of the Earth's radiation budget, and use of ASTER data for applications such as agricultural management requires atmospheric correction.

Constraints

This description applies to the atmospheric correction method used for the solar-reflective bands only for clear-sky pixels. This algorithm requires a digital elevation model providing slope and elevation for accurate modeling of surface reflectance. The model requires total and component optical depths as input. The algorithm is computed only for daytime image data for the VNIR - SWIR bands. The algorithm begins to break down at large view angles (not applicable for ASTER) and large solar zenith angles (>75 degrees). The algorithm's accuracy also degrades somewhat in regions around the backscatter direction due to strong surface BRDF effects. Uncertainty in the results also increases in regions of atmospheric heterogeneity



Surface Radiance – TIR

| | |
|---------------------------|---|
| Lead Investigator: | Frank Palluconi |
| Short Name: | AST_09T |
| Product Level: | 2 |
| Production Mode: | On-Demand |
| Absolute Accuracy: | 2% |
| Relative Accuracy: | 1% |
| Horizontal Resolution: | 90 m |
| Units: | $\text{W m}^{-2} \text{sr}^{-1} \mu\text{m}^{-1}$ |
| Product Size (Megabytes): | 14 |

Product Description

This product provides surface leaving radiance, in $\text{W m}^{-2} \text{sr}^{-1} \mu\text{m}^{-1}$, for the five ASTER TIR channels at 90 m spatial resolution. In addition, the down welling sky irradiance in $\text{W m}^{-2} \mu\text{m}^{-1}$ for the five ASTER TIR channels is also provided. Atmospheric correction has been applied and the surface leaving radiance is valid for the clear sky portion of scenes. This radiance includes both surface emitted and surface reflected components. The surface radiance is only of known accuracy for cloud-free pixels since insufficient information is available about cloud properties for a valid correction of cloudy pixels.

Accurate atmospheric correction is intended to remove the effect of the atmosphere providing the opportunity to use these radiances in the determination of surface spectral emissivity and surface kinetic temperature. This atmospheric correction, along with similar corrections for other Terra instruments, marks the first implementation of operational atmospheric correction in environmental satellites. This parameter is generated only upon request, and the data can be collected during either the daytime or nighttime.

Algorithm Description

The radiance measured by the ASTER instrument includes emission, absorption, and scattering by the constituents of the earth's atmosphere. The purpose of atmospheric correction is to remove these effects providing estimates of the radiation emitted and reflected at the surface. Atmospheric correction is necessary to isolate those features of the observation that are intrinsic to the surface from those caused by the atmosphere.

The approach involves two fundamental elements: 1) the use of a radiation transfer model capable of estimating the magnitude of atmosphere emission, absorption, and scattering, and 2) the acquisition of all the necessary atmospheric parameters (i.e. temperature, water vapor, ozone, aerosols) at the time and location of the measurement to be corrected. MODTRAN is the chosen radiation transfer model.

Applications

Surface leaving radiance is closely associated with the thermal properties of the surface itself nearly independent of the overlying atmosphere. If the spectral emissivity of the surface is



known, the surface kinetic temperature can be directly obtained given the information provided with this product. Surface kinetic temperature can be used in a number of applications ranging from derivations of sensible heat flux to estimates of plant stress. Several methods of separating surface leaving radiance into estimates of spectral emissivity and surface kinetic temperature exist including the algorithm used for this process by ASTER. Spectral emissivity can be used to estimate surface composition, which has wide application in geology, environmental assessment and urban planning.

Constraints

The surface leaving radiance is only of known accuracy for cloud-free pixels. As this data product does not correct for the presence of water or ice clouds it is of uncertain value when such clouds are present, however, a cloud mask is included in the quality assurance "QA plane" portion of the product, allowing the user to avoid cloudy pixels. In addition, the cloud identity products from MODIS and MISR may be used if the spatial resolution of these products is acceptable. This product is used within the ASTER operational data product production framework as an input to the generation of surface spectral emissivity for the five ASTER TIR channels and the derivation of surface kinetic temperature.



Surface Emissivity

| | |
|---------------------------|--------------------------------|
| Lead Investigator: | Alan Gillespie and S. Rokugawa |
| Short Name: | AST_05 |
| Product Level: | 2 |
| Production Mode: | On-Demand |
| Absolute Accuracy: | 0.05 - 0.1 |
| Relative Accuracy: | 0.005 |
| Horizontal Resolution: | 90 m |
| Units: | None |
| Product Size (Megabytes): | 9 |

Product Description

The Level-2 land surface emissivity product contains surface emissivity at 90-m resolution generated only over the land from ASTER's five thermal infrared channels. Surface emissivity is required to derive land surface temperature (AST08) data, also at a resolution of 90 meters. The emissivity product is critical for deriving accurate land surface temperatures. It is therefore important in studies of surface energy and water balance. The emissivity product is also useful for mapping geologic and land-cover features.

Current sensors provide only limited information useful for deriving surface emissivity and researchers are required to use emissivity surrogates such as land-cover type or vegetation index in making rough estimates of emissivity and hence land surface temperatures. The five thermal infrared channels of the ASTER instrument enable direct surface emissivity estimates. Mapping of thermal features from optical sensors such as Landsat and AVHRR has been used for many developmental studies. These instruments, however, lack the spectral coverage, resolution and radiometric accuracy that will be provided by the ASTER instrument.

Algorithm Description

Read in the land-leaving radiance and down-welling sky irradiance vectors for each pixel. Estimate the emissivity spectrum using the Normalized Emissivity Method and iteratively compensate for reflected skylight. Normalize the emissivity spectrum using the average emissivity for each pixel. Calculate the min-max difference (MMD) of the normalized spectrum and estimate the minimum emissivity using a regression that relates the MMD and the minimum emissivity. Scale the normalized emissivities using the minimum emissivity. Compensate for reflected skylight using the refined emissivities. Use the emissivity value to calculate a temperature using Planck's Law.

Applications

Emissivity is useful in identifying surface composition. Many minerals -- especially silicate minerals that make up the bulk of the Earth's surface -- have distinctive thermal infrared emissivity spectra, but ambiguous or non-distinctive VNIR spectra. Quartz, feldspars, amphiboles, and pyroxenes all are in this category. Carbonate rocks also have distinctive



spectra, although the diagnostic features are unresolved by ASTER. Because other minerals -- especially iron-bearing and hydrated minerals -- have distinctive VNIR and SWIR spectra, surface composition mapping is best undertaken with the full range of ASTER bands, not just the TIR bands alone.

Rock and soil emissivities also contrast with vegetation, snow and water. Therefore, emissivity data are useful for mapping forest clearings and snow coverage.

Atmospheric gases such as SO_2 , emitted from volcanoes, absorb ground-emitted thermal radiation selectively. Therefore, emissivity maps are useful in recognizing the presence of volcanic emissions, although special processing is required to quantify them. The same comments apply to industrial pollution.

Constraints

Currently there are no constraints, and the algorithm should work with TIR data acquired during the day or night. The algorithm will return incorrect values for clouds, however, because the atmospheric corrections will have been inaccurate due to a lack of knowledge of cloud height. Therefore, if a pixel is classified as "cloud" on the basis of its spectral and temperature characteristics a notation to that effect will be made in the QA plane. Because clouds radiate to the ground, pixels not covered by clouds but in their vicinity will also have inaccurate emissivities and spectra, and therefore these pixels are also noted in the QA plane. For cold surfaces viewed through a warm or humid atmosphere correction for reflected skylight can be inaccurate, leading to inaccurate emissivity estimates.



Surface Kinetic Temperature

| | |
|---------------------------|--------------------------------|
| Lead Investigator: | Alan Gillespie and S. Rokugawa |
| Short Name: | AST_08 |
| Product Level: | 2 |
| Production Mode: | On-Demand |
| Absolute Accuracy: | 1-4 K |
| Relative Accuracy: | 0.3 K |
| Horizontal Resolution: | 90 m |
| Units: | degrees K |
| Product Size (Megabytes): | 3.5 |

Product Description

The Level-2 land surface kinetic temperature product contains surface temperatures at 90-m resolution generated only over the land from ASTER's five thermal infrared channels. Land surface temperatures are determined from Planck's Law, using the emissivities from AST05 to scale the measured radiances after correction for atmospheric effects. Surface temperatures are important in studies of surface energy and water balance. They are also useful in studies of volcanism and thermal pollution.

Current sensors provide only limited information useful for deriving surface emissivity, and therefore land surface temperature estimates can be inaccurate. The five thermal infrared channels of the ASTER instrument enable direct surface emissivity estimates, and accurate temperature estimation.

Algorithm Description See AST_05, Surface Emissivity.

Applications

The derived land surface temperature has applications in studies of surface energy and water balance. Temperature data will be used in the monitoring and analysis of volcanic processes, day and night temperature data will be used to estimate thermal inertia, and thermal data will be used for high-resolution mapping of fires as a complement to MODIS global fire data. Thermal data are especially useful in fire studies because they can “see through” smoke to the burning terrain below.

Constraints

See AST_05, Surface Emissivity. For cold surfaces viewed through a warm or humid atmosphere correction for reflected skylight can be inaccurate, leading to inaccurate emissivity estimates. The error increases as the emissivity decreases. Therefore, even if some emissivities are erroneous, surface temperatures may be accurate, provided some of the emissivities are near unity.



Polar Surface and Cloud Classification

| | |
|---------------------------|-----------|
| Lead Investigator: | Ron Welch |
| Short Name: | AST13POL |
| Product Level: | 2 |
| Production Mode: | On-Demand |
| Absolute Accuracy: | 3% |
| Relative Accuracy: | 3% |
| Horizontal Resolution: | 30 m |
| Units: | None |
| Product Size (Megabytes): | 42 |

Product Description

This Level-2 product is a polar classification map. The polar regions are defined as all earth surfaces lying pole-ward from 60 N or 60 S. The algorithm classifies each pixel of a scene into 8 classes: water cloud, ice cloud, aerosol/dust, water, land, snow/ice, slush ice, and shadow. This product is produced at 30-m spatial resolution and uses a combination of visible, near-infrared and infrared channels. Both daytime and nighttime classifications will be available, with the daytime algorithm applied for solar zenith angles less than 85 degrees, and the nighttime algorithm applied in all cases using only thermal infrared channels. Only the daytime algorithm is available at this time. This is an on-request product.

This data product builds on work over the past decade with imagery taken from LANDSAT TM, AVIRIS, TIMS, and MAS satellite and aircraft sensors. The improved spectral coverage, resolution, and radiometric accuracy enables ASTER to provide remotely sensed polar data of unprecedented accuracy.

Algorithm Description

The methodology implemented in this algorithm is a neural-network classifier. The neural network technique is chosen because of its advantages in accuracy and speed when compared to more conventional techniques such as maximum likelihood. To classify a scene, additional spectral features first are generated from the original channels. Several of these additional features are nonlinear combinations of the original channels, which are constructed to improve separability between classes. Classification is then performed using a trained neural network classifier with as input an optimal subset of all features.

Applications

Since greenhouse forcings are expected to be amplified in the polar regions, the changes in these regions may act as early warning indicators of global climate shifts. Cloud cover is expected to be altered by greenhouse forcings, and cloud changes are expected to have a significant effect on sea ice conditions and regional ice-albedo feedbacks, especially to the polar heat balance which directly affects surface melting. ASTER polar data will be used to monitor changes in surface conditions, notably temperature, albedo, and sea ice breakup.



This ASTER polar data product also provides complementary validation to the global-scale polar data and cloud property retrievals from MODIS. In particular, this data set will be used to cross-validate the MODIS cloud optical thickness and effective particle sizes which directly impact the Earth's radiative budget. In addition, only ASTER has the spatial resolution necessary to fully analyze the three-dimensional effects of clouds.

Constraints

The daytime classification algorithm expects as input all the ASTER channels. Furthermore, the algorithm expects the gain selections for VNIR and SWIR channels to be both “LOW”. The algorithm has not been applied to data with other gain selections.

The nighttime algorithm utilizes only the thermal infrared channels as input. Furthermore, the nighttime algorithm is developed by using only thermal infrared channels of daytime images. This is due to the fact that the human experts are less confident in classifying thermal infrared images by visual inspection. Therefore, daytime images are used to create training data sets for the classifier.



Digital Elevation Model (DEM)

| | |
|----------------------------------|------------------------|
| Lead Investigator: | Mike Abrams, Roy Welch |
| Short Name: | AST14DEM |
| Product Level: | 3 |
| Production Mode: | On-Demand |
| Absolute Accuracy: | ≥ 7 m |
| Relative Accuracy: | ≥ 10 m |
| Horizontal Resolution: | 30 m |
| Units: | meters |
| Product Size (Megabytes): | 25 |

Product Description

This data set contains topographic information derived from the along-track, 15 m ASTER optical stereo data acquired in near-infrared bands 3N and 3B. It can be created as a Relative DEM (no ground control) or an Absolute DEM (with ground control, which must be supplied by the user). These high spatial resolution DEMs (up to 7 m absolute horizontal and vertical accuracy with appropriate ground control, and up to 10 m relative accuracy without ground control) can be used to derive absolute slope and slope aspect good to 5 degrees over horizontal distances of more than 100 m. ASTER DEMs should meet 1:50,000 to 1:250,000 map accuracy standards.

This is an on-request product which will be generated by the Land Processes DAAC at EROS Data Center at a rate of one 60 km X 60 km stereo pair/day. Based on simulations of instrument operations, mission planning, cloud cover and illumination, an ASTER digital stereo data set with a base/height ratio of 0.6 should be acquired for all of the Earth's land surface below 82 degrees latitude by the end of the 6 year mission. ASTER stereo pairs also can be processed to DEMs by users operating their own software.

Generation of elevation models from stereo photographic data, now a routine adjunct to standard surveying methods, has been developed over the past 60 years based on the principles of photogrammetry. Extensions of these principles to the generation of DEMs from optical, digital stereo satellite data has been implemented over the past two decades. Examples of these satellite stereo systems include SPOT, JERS-1 OPS, and MOMS. Currently, there are large areas of the globe for which no consistent, high-resolution, widely available elevation models exist. ASTER DEMs will help provide much needed coverage over many of these areas.

Algorithm Description

An autocorrelation approach using commercial software at the LP-DAAC will produce DEMs from Level-1A or 1B digital stereo pairs.

Applications

Topographic data as well as derived slope and slope aspect are basic to all aspects of land surface



research including; cartography, climate modeling, biogeochemistry, biogeography, geophysics, geology, geomorphology and soil science. Digital elevation data are also required for atmospheric and radiometric correction of most satellite observations of the land surface. Digital elevation data are also used for practical engineering applications such as studies of drainage and runoff, and site suitability studies for urban development, waste containment, and recreation.

Constraints

This product will be produced using off the shelf commercial software. Absolute accuracy depends on availability of user-provided ground control points.



Appendix III: Metadata Cross Reference Table

If you know the name of a metadata attribute, but don't know which hdf attribute contains it, use this table to find out. (Please ignore case--sometimes an item is represented in all upper case, sometimes in mixed or lower case.)



Attribute Name

Location

| | | |
|---------------------------|---------------------------------|---------------------------|
| | AdditionalAttributeName | coremetadata.0 |
| | ASTEROBSERVATIONMODE | |
| formatted_product_summary | ASTERObservationMode | productmetadata.0 |
| | ASTEROPERATIONMODE | |
| formatted_product_summary | ASTEROperationMode | productmetadata.0 |
| | ASTERSCENEID | formatted_product_summary |
| | ASTERSceneID | productmetadata.0 |
| | AUTOMATICQUALITYFLAG | |
| formatted_product_summary | AutomaticQualityFlag | coremetadata.0 |
| | AutomaticQualityFlagExplanation | |
| coremetadata.0 | AVERAGEOFFSET10 | level_1_carryover |
| | AVERAGEOFFSET11 | level_1_carryover |
| | AVERAGEOFFSET12 | level_1_carryover |
| | AVERAGEOFFSET13 | level_1_carryover |
| | AVERAGEOFFSET14 | level_1_carryover |
| | AVERAGEOFFSET4 | level_1_carryover |
| | AVERAGEOFFSET5 | level_1_carryover |
| | AVERAGEOFFSET6 | level_1_carryover |
| | AVERAGEOFFSET7 | level_1_carryover |
| | AVERAGEOFFSET8 | level_1_carryover |
| | AVERAGEOFFSET9 | level_1_carryover |
| | AVGCORRELCOEF4 | level_1_carryover |
| | AVGCORRELCOEF5 | level_1_carryover |
| | AVGCORRELCOEF6 | level_1_carryover |
| | AVGCORRELCOEF7 | level_1_carryover |
| | AVGCORRELCOEF8 | level_1_carryover |
| | AVGCORRELCOEF9 | level_1_carryover |
| | BadPixelSegments1 | badpixelinformation |
| | BadPixelSegments10 | badpixelinformation |
| | BadPixelSegments11 | badpixelinformation |
| | BadPixelSegments12 | badpixelinformation |
| | BadPixelSegments13 | badpixelinformation |
| | BadPixelSegments14 | badpixelinformation |
| | BadPixelSegments2 | badpixelinformation |
| | BadPixelSegments3B | badpixelinformation |
| | BadPixelSegments3N | badpixelinformation |
| | BadPixelSegments4 | badpixelinformation |
| | BadPixelSegments5 | badpixelinformation |



Attribute NameLocation

| | | |
|---------------------------|-------------------------|---------------------------|
| | BadPixelSegments6 | badpixelinformation |
| | BadPixelSegments7 | badpixelinformation |
| | BadPixelSegments8 | badpixelinformation |
| | BadPixelSegments9 | badpixelinformation |
| | BandScaleFactors | productmetadata.0 |
| | BANDSCALEFACTORS | |
| formatted_product_summary | CALENDARDATE | formatted_product_summary |
| | CalendarDate | coremetadata.0 |
| | COARSEDEMVERSION | |
| formatted_product_summary | CoarseDEMVersion | productmetadata.0 |
| | CORINTEL1 | level_1_carryover |
| | CORINTEL10 | level_1_carryover |
| | CORINTEL11 | level_1_carryover |
| | CORINTEL12 | level_1_carryover |
| | CORINTEL13 | level_1_carryover |
| | CORINTEL14 | level_1_carryover |
| | CORINTEL2 | level_1_carryover |
| | CORINTEL3B | level_1_carryover |
| | CORINTEL3N | level_1_carryover |
| | CORINTEL4 | level_1_carryover |
| | CORINTEL5 | level_1_carryover |
| | CORINTEL6 | level_1_carryover |
| | CORINTEL7 | level_1_carryover |
| | CORINTEL8 | level_1_carryover |
| | CORINTEL9 | level_1_carryover |
| | CORPARA1 | level_1_carryover |
| | CORPARA10 | level_1_carryover |
| | CORPARA11 | level_1_carryover |
| | CORPARA12 | level_1_carryover |
| | CORPARA13 | level_1_carryover |
| | CORPARA14 | level_1_carryover |
| | CORPARA2 | level_1_carryover |
| | CORPARA3B | level_1_carryover |
| | CORPARA3N | level_1_carryover |
| | CORPARA4 | level_1_carryover |
| | CORPARA5 | level_1_carryover |
| | CORPARA6 | level_1_carryover |
| | CORPARA7 | level_1_carryover |



Attribute NameLocation

| | | |
|---------------------------|--------------------------|---------------------------|
| | CORPARA8 | level_1_carryover |
| | CORPARA9 | level_1_carryover |
| | CTHLD4 | level_1_carryover |
| | CTHLD5 | level_1_carryover |
| | CTHLD6 | level_1_carryover |
| | CTHLD7 | level_1_carryover |
| | CTHLD8 | level_1_carryover |
| | CTHLD9 | level_1_carryover |
| | DayNightFlag | coremetadata.0 |
| | EASTBOUNDINGCOORDINATE | |
| formatted_product_summary | EastBoundingCoordinate | coremetadata.0 |
| | ExclusionGRingFlag | coremetadata.0 |
| | FlyingDirection | productmetadata.0 |
| | FutureReviewDate | coremetadata.0 |
| | GAIN | formatted_product_summary |
| | Gain | productmetadata.0 |
| | GenerationDateandTime | productmetadata.0 |
| | GENERATIONDATEANDTIME | |
| level_1_carryover | GEOMETRICDBVERSION | |
| formatted_product_summary | GeometricDBVersion | productmetadata.0 |
| | GRingPointLatitude | coremetadata.0 |
| | GRingPointLongitude | coremetadata.0 |
| | GRingPointSequenceNo | coremetadata.0 |
| | IDOFASTERGDSDATAGRANULE | |
| level_1_carryover | IDofASTERGDSDataGranule | |
| productmetadata.0 | InputPointer | coremetadata.0 |
| | INSTRUMENTSHORTNAME | |
| formatted_product_summary | InstrumentShortName | coremetadata.0 |
| | LocalGranuleID | coremetadata.0 |
| | LOWERLEFT | formatted_product_summary |
| | LowerLeft | productmetadata.0 |
| | LowerRight | productmetadata.0 |
| | LOWERRIGHT | formatted_product_summary |
| | MAPPROJECTIONNAME | |
| formatted_product_summary | MapProjectionName | coremetadata.0 |
| | MEASUREMENTPOINTNUMBER10 | |
| level_1_carryover | MEASUREMENTPOINTNUMBER11 | |



level_1_carryover

MEASUREMENTPOINTNUMBER12

level_1_carryover



Attribute NameLocation

| | |
|---------------------------|--|
| level_1_carryover | MEASUREMENTPOINTNUMBER13 |
| level_1_carryover | MEASUREMENTPOINTNUMBER14 |
| level_1_carryover | MEASUREMENTPOINTNUMBER4 |
| level_1_carryover | MEASUREMENTPOINTNUMBER5 |
| level_1_carryover | MEASUREMENTPOINTNUMBER6 |
| level_1_carryover | MEASUREMENTPOINTNUMBER7 |
| level_1_carryover | MEASUREMENTPOINTNUMBER8 |
| level_1_carryover | MEASUREMENTPOINTNUMBER9 |
| | MPMETHOD1 level_1_carryover |
| | MPMETHOD10 level_1_carryover |
| | MPMETHOD11 level_1_carryover |
| | MPMETHOD12 level_1_carryover |
| | MPMETHOD13 level_1_carryover |
| | MPMETHOD14 level_1_carryover |
| | MPMETHOD2 level_1_carryover |
| | MPMETHOD3B level_1_carryover |
| | MPMETHOD3N level_1_carryover |
| | MPMETHOD4 level_1_carryover |
| | MPMETHOD5 level_1_carryover |
| | MPMETHOD6 level_1_carryover |
| | MPMETHOD7 level_1_carryover |
| | MPMETHOD8 level_1_carryover |
| | MPMETHOD9 level_1_carryover |
| | NORTHBOUNDINGCOORDINATE |
| formatted_product_summary | NorthBoundingCoordinate coremetadata.0 |
| | NUMBEROFBADPIXELS1 level_1_carryover |
| | NUMBEROFBADPIXELS10 |
| level_1_carryover | NUMBEROFBADPIXELS11 |
| level_1_carryover | NUMBEROFBADPIXELS12 |
| level_1_carryover | NUMBEROFBADPIXELS13 |
| level_1_carryover | NUMBEROFBADPIXELS14 |
| level_1_carryover | |



level_1_carryover

level_1_carryover

NUMBEROFBADPIXELS2 level_1_carryover
NUMBEROFBADPIXELS3B

NUMBEROFBADPIXELS3N

NUMBEROFBADPIXELS4 level_1_carryover
NUMBEROFBADPIXELS5 level_1_carryover
NUMBEROFBADPIXELS6 level_1_carryover
NUMBEROFBADPIXELS7 level_1_carryover



Attribute NameLocation

| | | |
|-------------------|-----------------------------------|------------------------|
| | NUMBEROFBADPIXELS8 | level_1_carryover |
| | NUMBEROFBADPIXELS9 | level_1_carryover |
| | NumberOfElement1 | badpixelinformation |
| | NumberOfElement10 | badpixelinformation |
| | NumberOfElement11 | badpixelinformation |
| | NumberOfElement12 | badpixelinformation |
| | NumberOfElement13 | badpixelinformation |
| | NumberOfElement14 | badpixelinformation |
| | NumberOfElement2 | badpixelinformation |
| | NumberOfElement3B | badpixelinformation |
| | NumberOfElement3N | badpixelinformation |
| | NumberOfElement4 | badpixelinformation |
| | NumberOfElement5 | badpixelinformation |
| | NumberOfElement6 | badpixelinformation |
| | NumberOfElement7 | badpixelinformation |
| | NumberOfElement8 | badpixelinformation |
| | NumberOfElement9 | badpixelinformation |
| | NUMBEROFMEASUREMENTS10 | |
| level_1_carryover | | NUMBEROFMEASUREMENTS11 |
| level_1_carryover | | NUMBEROFMEASUREMENTS12 |
| level_1_carryover | | NUMBEROFMEASUREMENTS13 |
| level_1_carryover | | NUMBEROFMEASUREMENTS14 |
| level_1_carryover | | NUMBEROFMEASUREMENTS4 |
| level_1_carryover | | NUMBEROFMEASUREMENTS5 |
| level_1_carryover | | NUMBEROFMEASUREMENTS6 |
| level_1_carryover | | NUMBEROFMEASUREMENTS7 |
| level_1_carryover | | NUMBEROFMEASUREMENTS8 |
| level_1_carryover | | NUMBEROFMEASUREMENTS9 |
| | OperationalQualityFlag | coremetadata.0 |
| | OperationalQualityFlagExplanation | |
| coremetadata.0 | OrbitNumber | productmetadata.0 |
| | ParameterName | coremetadata.0 |
| | ParameterValue | coremetadata.0 |



| | |
|----------------|-------------------|
| PCTIMAGEMATCH4 | level_1_carryover |
| PCTIMAGEMATCH5 | level_1_carryover |
| PCTIMAGEMATCH6 | level_1_carryover |
| PCTIMAGEMATCH7 | level_1_carryover |
| PCTIMAGEMATCH8 | level_1_carryover |



Attribute NameLocation

| | | |
|---------------------------|------------------------|---------------------------|
| | PCTIMAGEMATCH9 | level_1_carryover |
| | PGEVersion | coremetadata.0 |
| | PGEVERSION | formatted_product_summary |
| | PlatformShortName | coremetadata.0 |
| | PointingAngle | productmetadata.0 |
| | POINTINGINFO | formatted_product_summary |
| | PROCESSEDBANDS | level_1_carryover |
| | ProcessedBands | productmetadata.0 |
| | ProcessingCenter | productmetadata.0 |
| | PROCESSINGCENTER | |
| formatted_product_summary | | |
| | PROCESSINGCENTER | level_1_carryover |
| | PROCESSINGFLAG10 | level_1_carryover |
| | PROCESSINGFLAG11 | level_1_carryover |
| | PROCESSINGFLAG12 | level_1_carryover |
| | PROCESSINGFLAG13 | level_1_carryover |
| | PROCESSINGFLAG14 | level_1_carryover |
| | PROCESSINGFLAG4 | level_1_carryover |
| | PROCESSINGFLAG5 | level_1_carryover |
| | PROCESSINGFLAG6 | level_1_carryover |
| | PROCESSINGFLAG7 | level_1_carryover |
| | PROCESSINGFLAG8 | level_1_carryover |
| | PROCESSINGFLAG9 | level_1_carryover |
| | PROCESSLEVELID | formatted_product_summary |
| | ProcessLevelID | coremetadata.0 |
| | PROJECTIONPARAMETERS1 | |
| level_1_carryover | | |
| | PROJECTIONPARAMETERS10 | |
| level_1_carryover | | |
| | PROJECTIONPARAMETERS11 | |
| level_1_carryover | | |
| | PROJECTIONPARAMETERS12 | |
| level_1_carryover | | |
| | PROJECTIONPARAMETERS13 | |
| level_1_carryover | | |
| | PROJECTIONPARAMETERS14 | |
| level_1_carryover | | |
| | PROJECTIONPARAMETERS2 | |
| level_1_carryover | | |
| | PROJECTIONPARAMETERS3B | |
| level_1_carryover | | |
| | PROJECTIONPARAMETERS3N | |
| level_1_carryover | | |
| | PROJECTIONPARAMETERS4 | |
| level_1_carryover | | |



level_1_carryover

PROJECTIONPARAMETERS5

level_1_carryover

PROJECTIONPARAMETERS6

level_1_carryover

PROJECTIONPARAMETERS7

level_1_carryover

PROJECTIONPARAMETERS8



Attribute NameLocation

PROJECTIONPARAMETERS9

| | |
|---------------------------|---|
| level_1_carryover | QAAlertEigenvalOOR QA_alert_table QAAlertLUTEextrpReqd QA_alert_table QAAlertNumAddlBadPixels QA_alert_table QAAlertNumPixAllBndsOOR |
| QA_alert_table | QAAlertNumTempImposs QA_alert_table QAAlertNumTempOOR QA_alert_table QAAlertOffDiagElemOOR QA_alert_table QAAlertOffDiagInpLTLim QA_alert_table QAAlertPctBadPixels QA_alert_table QAAlertPctFailPixels QA_alert_table QAAlertPctHiUncertPixels QA_alert_table QAALERTSUMMARY |
| formatted_product_summary | QACritAlertsCnt QA_alert_table QANonCritAlertsCnt QA_alert_table QAPercentCloudCover coremetadata.0 QAPERCENTINTERPOLATEDDATA |
| formatted_product_summary | QAPercentInterpolatedData coremetadata.0 QAPercentMissingData coremetadata.0 QAPERCENTMISSINGDATA |
| formatted_product_summary | QAPERCENTOUTOFBOUNDSDATA |
| formatted_product_summary | QAPercentOutofBoundsData coremetadata.0 QASatLUTEextrpReqd QA_alert_table QASatNumAddlBadPixels QA_alert_table QASatNumPixAllBndsOOR QA_alert_table QASatNumTempOOR QA_alert_table QASatPctBadPixels QA_alert_table QASatPctFailPixels QA_alert_table QASatPctHiUncertPixels QA_alert_table QASummaryOfAlerts QA_alert_table QuadrantCloudCoverage productmetadata.0 QUADRANTCLOUDCOVERAGER |
| formatted_product_summary | QUADRANTCLOUDCOVERAGER |
| level_1_carryover | RadiometricDBVersion productmetadata.0 RADIOMETRICDBVERSION |
| formatted_product_summary | RECEIVINGCENTER |



formatted_product_summary

ReceivingCenter productmetadata.0
RecurrentCycleNumber productmetadata.0



Attribute NameLocation

| | |
|---------------------------|--|
| | ReprocessingActual coremetadata.0 |
| | REPROCESSINGACTUAL |
| formatted_product_summary | |
| | RESMETHOD1 level_1_carryover |
| | RESMETHOD10 level_1_carryover |
| | RESMETHOD11 level_1_carryover |
| | RESMETHOD12 level_1_carryover |
| | RESMETHOD13 level_1_carryover |
| | RESMETHOD14 level_1_carryover |
| | RESMETHOD2 level_1_carryover |
| | RESMETHOD3B level_1_carryover |
| | RESMETHOD3N level_1_carryover |
| | RESMETHOD4 level_1_carryover |
| | RESMETHOD5 level_1_carryover |
| | RESMETHOD6 level_1_carryover |
| | RESMETHOD7 level_1_carryover |
| | RESMETHOD8 level_1_carryover |
| | RESMETHOD9 level_1_carryover |
| | SceneCenter productmetadata.0 |
| | SCENECENTER formatted_product_summary |
| | SceneCloudCoverage productmetadata.0 |
| | SCENECLLOUDCOVERAGE |
| level_1_carryover | |
| | SCENECLLOUDCOVERAGE |
| formatted_product_summary | |
| | SceneOrientationAngle productmetadata.0 |
| | SCENEORIENTATIONANGLE |
| formatted_product_summary | |
| | ScienceReviewDate coremetadata.0 |
| | SensorName productmetadata.0 |
| | SettingTimeofPointing productmetadata.0 |
| | ShortName coremetadata.0 |
| | SizeMBECSDataGranule coremetadata.0 |
| | SIZEMBECSDATAGRANULE |
| formatted_product_summary | |
| | SolarDirection productmetadata.0 |
| | SOLARDIRECTION formatted_product_summary |
| | SourceDataProduct productmetadata.0 |
| | SOURCEDATAPRODUCT |
| formatted_product_summary | |
| | SOURCEDATAPRODUCT level_1_carryover |
| | SouthBoundingCoordinate coremetadata.0 |
| | SOUTHBOUNDINGCOORDINATE |
| formatted_product_summary | |
| | SpatialResolution productmetadata.0 |



Attribute NameLocation

| | | |
|---------------------------|---------------------------|---------------------------|
| formatted_product_summary | SPATIALRESOLUTION | |
| level_1_carryover | STANDARDDEVIATIONOFFSET10 | |
| level_1_carryover | STANDARDDEVIATIONOFFSET11 | |
| level_1_carryover | STANDARDDEVIATIONOFFSET12 | |
| level_1_carryover | STANDARDDEVIATIONOFFSET13 | |
| level_1_carryover | STANDARDDEVIATIONOFFSET14 | |
| level_1_carryover | STANDARDDEVIATIONOFFSET4 | |
| level_1_carryover | STANDARDDEVIATIONOFFSET5 | |
| level_1_carryover | STANDARDDEVIATIONOFFSET6 | |
| level_1_carryover | STANDARDDEVIATIONOFFSET7 | |
| level_1_carryover | STANDARDDEVIATIONOFFSET8 | |
| level_1_carryover | STANDARDDEVIATIONOFFSET9 | |
| | THRESHOLD10 | level_1_carryover |
| | THRESHOLD11 | level_1_carryover |
| | THRESHOLD12 | level_1_carryover |
| | THRESHOLD13 | level_1_carryover |
| | THRESHOLD14 | level_1_carryover |
| | THRESHOLD4 | level_1_carryover |
| | THRESHOLD5 | level_1_carryover |
| | THRESHOLD6 | level_1_carryover |
| | THRESHOLD7 | level_1_carryover |
| | THRESHOLD8 | level_1_carryover |
| | THRESHOLD9 | level_1_carryover |
| | TIMEOFDAY | formatted_product_summary |
| | TimeofDay | coremetadata.0 |
| | UPPERLEFT | formatted_product_summary |
| | UpperLeft | productmetadata.0 |
| | UPPERRIGHT | formatted_product_summary |
| | UpperRight | productmetadata.0 |
| | UTMZONECODE1 | level_1_carryover |
| | UTMZONECODE10 | level_1_carryover |
| | UTMZONECODE11 | level_1_carryover |
| | UTMZONECODE12 | level_1_carryover |



UTMZONECODE13 level_1_carryover
UTMZONECODE14 level_1_carryover
UTMZONECODE2 level_1_carryover
UTMZONECODE3B level_1_carryover
UTMZONECODE3N level_1_carryover



Attribute NameLocation

UTMZONECODE4 level_1_carryover
UTMZONECODE5 level_1_carryover
UTMZONECODE6 level_1_carryover
UTMZONECODE7 level_1_carryover
UTMZONECODE8 level_1_carryover
UTMZONECODE9 level_1_carryover
VersionID coremetadata.0
WESTBOUNDINGCOORDINATE

formatted_product_summary

WestBoundingCoordinate coremetadata.0



Appendix IV: Public Domain Software for Handling HDF-EOS Format

ASTER data products are stored in a specific implementation of HDF called HDF-EOS. This format is very flexible and accommodates the wide range of products available from the EOS instruments. Although HDF is a flexible storage format, it can be a daunting task getting data out of HDF and into a users image analysis and display package. Fortunately several image analysis and display packages are able to ingest ASTER data making it easy for users that have those packages to begin working with the data. Users are cautioned that some of these packages do not always ingest the files correctly and care should be taken to check the file has been ingested correctly. There are also other programs that allow users to search the metadata associated with a product. The EOS project maintains a list of software packages that are able to work with EOS data at:

<http://hdfeos.gsfc.nasa.gov/hdfeos/viewingHDFEOS.html>

There have been a number of public domain software packages to handle HDF-EOS that have been developed over the last few years. Following is a list of such software and URL addresses to procure them:

1) **WINVICAR**: JPL has developed an image analysis package (WINVICAR) that works under Windows NT, 2000 and XP. This package includes programs for getting ASTER data out of HDF and into ASCII, BINARY and WINVICAR format. There are also programs to dump the metadata from ASTER data files. For more information: <http://winvicar.jpl.nasa.gov>

2) **HEG (HDF-to-GeoTiff) Tool**: This tool was developed by the ECS Project Office to fulfill the needs of the image processing and GIS communities as they grappled with the HDF-EOS format. The tool converts HDF-EOS swath and grid data to HDF-EOS Grid, GeoTIFF, or to a generic binary format. The tool can be used to re-project data from its original format to other standard projections, to subset data and to mosaic adjacent files together. Swath data can also be converted to Grid data. For more information:

<http://hdfeos.gsfc.nasa.gov/hdfeos/details.cfm?swID=4>

HEG's User Guide is available from:

http://hdfeos.gsfc.nasa.gov/hdfeos/software/HEG/HEG_UsersGuide.pdf

3) **Java HDF Viewer (JHV)**: This is a visualization tool developed by NCSA for browsing HDF4 files. It has a nested hierarchical structure that allows easy navigation of the different component object files. Since it is written in Java, it is machine-independent, and hence easily portable across platforms. For more information: <http://hdf.ncsa.uiuc.edu/java-hdf-html/jhv/> JHV's User Guide is available from:

<ftp://ftp.ncsa.uiuc.edu/HDF/HDF/java/source/unpacked/docs/UsersGuide/JHV2.7/index.html>

4) **MultiSpec**: This is a tool developed by Purdue University for interactively analyzing multispectral and hyperspectral image data serving especially the Macintosh and Windows platforms. For more information: <http://www.ece.purdue.edu/~biehl/MultiSpec/>



5) **Webwinds:** This is a java-based visualization tool developed by Lee Elson and his team at JPL. It supports a range of different functions and runs on a variety of platforms. For more information: <http://www.sci-conservices.com/rel4/webpage/wwhome.html>

Documentation on Webwinds is available from:

<http://www.sci-conservices.com/rel4/webpage/webhelp.html>

There are yet more public domain software packages that are available that include HDF and HDF-EOS utilities, format converters, and metadata readers. If you are interested in any of them, a good starting point would be the EOS/ECS project office's hdfeos page:

<http://hdfeos.gsfc.nasa.gov/hdfeos/softwarelist.cfm>



Appendix V: LP-DAAC Data Sets Available through EDC via the EDG

DATA CENTER Defined as: EDC-ECS (ECS LAND PROCESSES DAAC)

EOSDIS Core System Data Sets:

ASTER L1A Reconstructed Unprocessed Instrument Data V002
 ASTER L1B Registered Radiance at Sensor V002
 ASTER L2 Decorrelation Stretch VNIR V002
 ASTER L2 Decorrelation Stretch SWIR V002
 ASTER L2 Decorrelation Stretch TIR V002
 ASTER Digital Elevation Model V002
 ASTER Expedited L1A Reconstructed Unprocessed Instrument Data V002
 ASTER Expedited L1B Registered Radiance at Sensor V002

ASTER L1A Reconstructed Unprocessed Instrument Data V003
 ASTER L1B Registered Radiance at Sensor V003
 ASTER L2 Decorrelation Stretch VNIR V003
 ASTER L2 Decorrelation Stretch SWIR V003
 ASTER L2 Decorrelation Stretch TIR V003
 ASTER Digital Elevation Model V003
 ASTER Expedited L1A Reconstructed Unprocessed Instrument Data V003
 ASTER Expedited L1B Registered Radiance at Sensor V003

MODIS/Terra Albedo 16-Day L3 Global 1km ISIN Grid V001
 MODIS/Terra BRDF/Albedo Model-1 16-Day L3 Global 1km ISIN Grid V001
 MODIS/Terra Geolocation Angles Daily L2G Global 1km ISIN Grid Day V001
 MODIS/Terra Geolocation Angles Daily L2G Global 1km ISIN Grid Night V001
 MODIS/Terra Land Cover Type 96-Day L3 Global 1km ISIN Grid V001
 MODIS/Terra Land Surface Temperature/Emissivity 5-Min L2 Swath 1km V001
 MODIS/Terra Land Surface Temperature/Emissivity 8-Day L3 Global 1km ISIN Grid V001
 MODIS/Terra Land Surface Temperature/Emissivity Daily L3 Global 1km ISIN Grid V001
 MODIS/Terra Leaf Area Index/FPAR 8-Day L4 Global 1km ISIN Grid V001
 MODIS/Terra Nadir BRDF-Adjusted Reflectance 16-Day L3 Global 1km ISIN Grid V001
 MODIS/Terra Net Photosynthesis 8-Day L4 Global 1km ISIN Grid V001
 MODIS/Terra Observation Pointers Daily L2G Global 1km ISIN Grid Day V001
 MODIS/Terra Observation Pointers Daily L2G Global 1km ISIN Grid Night V001
 MODIS/Terra Observation Pointers Daily L2G Global 500m ISIN Grid V001
 MODIS/Terra Surface Reflectance 8-Day L3 Global 500m ISIN Grid V001
 MODIS/Terra Surface Reflectance Daily L2G Global 500m ISIN Grid V001
 MODIS/Terra Surface Reflectance Quality Daily L2G Global 1km ISIN Grid V001
 MODIS/Terra Thermal Anomalies/Fire 5-Min L2 Swath 1km V001
 MODIS/Terra Thermal Anomalies/Fire 8-Day L3 Global 1km ISIN Grid V001
 MODIS/Terra Thermal Anomalies/Fire Daily L2G Global 1km ISIN Grid Day V001
 MODIS/Terra Thermal Anomalies/Fire Daily L2G Global 1km ISIN Grid Night V001
 MODIS/Terra Thermal Anomalies/Fire Daily L3 Global 1km ISIN Grid V001
 MODIS/Terra Vegetation Indices 16-Day L3 Global 1km ISIN Grid V001



MODIS/Terra Vegetation Indices 16-Day L3 Global 500m ISIN Grid V001

- MODIS/Terra Albedo 16-Day L3 Global 0.25Deg CMG V003
- MODIS/Terra Albedo 16-Day L3 Global 1km ISIN Grid V003
- MODIS/Terra BRDF/Albedo Model-1 16-Day L3 Global 1km ISIN Grid V003
- MODIS/Terra BRDF/Albedo Parameters 16-Day L3 Global 0.25Deg CMG V003
- MODIS/Terra Geolocation Angles Daily L2G Global 1km ISIN Grid Day V003
- MODIS/Terra Geolocation Angles Daily L2G Global 1km ISIN Grid Night V003
- MODIS/Terra Land Cover Type 96-Day L3 Global 1km ISIN Grid V003
- MODIS/Terra Land Surface Temperature/Emissivity 5-Min L2 Swath 1km V003
- MODIS/Terra Land Surface Temperature/Emissivity 8-Day L3 Global 1km ISIN Grid V003
- MODIS/Terra Land Surface Temperature/Emissivity Daily L3 Global 1km ISIN Grid V003
- MODIS/Terra Land Surface Temperature/Emissivity Daily L3 Global 5km ISIN Grid V003
- MODIS/Terra Leaf Area Index/FPAR 8-Day L4 Global 1km ISIN Grid V003
- MODIS/Terra Nadir BRDF-Adjusted Reflectance 16-Day L3 Global 1km ISIN Grid V003
- MODIS/Terra Net Photosynthesis 8-Day L4 Global 1km ISIN Grid V003
- MODIS/Terra Observation Pointers Daily L2G Global 1km ISIN Grid Day V003
- MODIS/Terra Observation Pointers Daily L2G Global 1km ISIN Grid Night V003
- MODIS/Terra Observation Pointers Daily L2G Global 250m ISIN Grid V003
- MODIS/Terra Observation Pointers Daily L2G Global 500m ISIN Grid V003
- MODIS/Terra Surface Reflectance 8-Day L3 Global 250m ISIN Grid V003
- MODIS/Terra Surface Reflectance 8-Day L3 Global 500m ISIN Grid V003
- MODIS/Terra Surface Reflectance Daily L2G Global 250m ISIN Grid V003
- MODIS/Terra Surface Reflectance Daily L2G Global 500m ISIN Grid V003
- MODIS/Terra Surface Reflectance Quality Daily L2G Global 1km ISIN Grid V003
- MODIS/Terra Thermal Anomalies/Fire 5-Min L2 Swath 1km V003
- MODIS/Terra Thermal Anomalies/Fire 8-Day L3 Global 1km ISIN Grid V003
- MODIS/Terra Thermal Anomalies/Fire Daily L2G Global 1km ISIN Grid Day V003
- MODIS/Terra Thermal Anomalies/Fire Daily L2G Global 1km ISIN Grid Night V003
- MODIS/Terra Thermal Anomalies/Fire Daily L3 Global 1km ISIN Grid V003
- MODIS/Terra Vegetation Indices 16-Day L3 Global 1km ISIN Grid V003
- MODIS/Terra Vegetation Indices 16-Day L3 Global 250m ISIN Grid V003
- MODIS/Terra Vegetation Indices 16-Day L3 Global 500m ISIN Grid V003

- Landsat-7 Calibration Parameter File V002
- Landsat-7 LOR Floating Scenes V002
- Landsat-7 Level-0R WRS-Scene V002

DATA CENTER Defined as: EDC-L1 (L1 LAND PROCESSES DAAC)

- Landsat-7 Level-0R IGS Scene Metadata V002
- Landsat-7 Level-1 Floating Scenes V002
- Landsat-7 Level-1 WRS-Scene V002



ASTER Users Handbook

DATA CENTER Defined as: EDC (LAND PROCESSES DAAC)

Non-EOSDIS Core System Data Sets:

Advanced Solid-State Array Spectroradiometer Data Collection

Aircraft Scanners

AVHRR 1-KM Orbital Segments

Global 30-Arc Second Elevation Data Set

Global Land Cover Test Sites

NASA Landsat Data Collection

North American Landscape Characterization

Spaceborne Imaging Radar-C Precision