

NILU : EMEP/CCC-Report 1/95
REFERENCE : O-7726
DATE : MARCH 1996

REVISION : NOVEMBER 2001

**EMEP Co-operative Programme for Monitoring and Evaluation
of the Long-range Transmission of Air Pollutants in Europe**

EMEP manual for sampling and chemical analysis



Norwegian Institute for Air Research
P.O. Box 100
N-2007 Kjeller, Norway
Tel.: +47 63898000 – Fax: +47 63898050

Revisions

Revision	Date of release	Pages affected
1/96	29 March 1996	All pages
1/2001	November 2001	Ch. 1 Ch. 3.2 to 3.7 (page 3-13 to 3-51) Ch. 3.10-12 and 4.17-18 New chapters on heavy metals Ch. 3.13 and 4.19 New chapters on PCBs Ch. 3.14 and 4.20 New chapters on PAHs – pages Ch. 5.1 Revised “Job description for EMEP’s NQAM” – page 5-2 Ch. 5.2 New “EMEP Data Quality Objectives (DQO)” – Pages 5-3 – 5-4 Minor changes on pages 3-3, 3-60, 5-5, 5-9, 5-10, 5-12, 5-14, 5-21, 6-14
1/2002	May 2002	Ch. 6.4 New flag system – pages 6-9 – 6-13 Ch. 3.15 and 4.21 New chapters on particulate matter

The Chemical Co-ordination Centre of EMEP (CCC) will forward future revisions to EMEP’s National Quality Assurance Managers, to the EMEP participating laboratories and to members of the Steering Body of EMEP. Other scientists will receive the revisions upon request to the CCC. When requiring a revised version, a copy of this page should be enclosed.

Preface

This Manual replaces the Manual for Sampling and Chemical Analysis from 1977, which was worked out in EMEP's start phase. The first revision of this manual came in 1996 where major parts have been rewritten and complemented with methods for more components such as methods for volatile organic components. Many of the methods both for sampling and analysis from the early years were replaced by new and better methods in order to meet today's more strict requirements to data quality. The Manual was extended with a section on quality assurance, which is based on the Quality Assurance Plan for EMEP.

In 2001 the manual was updated including heavy metals, PCB and PAHs. The present version is extended further including measurements of particulate matter.

Revisions and extensions in the manual are also expected in the years to come. The newest version is always found on the online homepage of the EMEP manual, <http://www.nilu.no/projects/ccc/manual/index.html>

Many scientists have contributed with large or small parts to this Manual. In alphabetic order we have contributions from Torunn Berg, Christian Dye, Jan Erik Hanssen, Terje Krognnes, John Munthe, Anni Reissell, Jan Schaug, Norbert Schmidbauer, Arne Semb, Kjetil Tørseth, Hilde Thelle Uggerud and Wenche Aas. Kristine Aasarød and Lisbeth Berntsen Storaas have put together our typed and handwritten contributions and the many changes in the text into one Manual.

Norwegian Institute for Air Research

Contents

	Page
Preface	i
1. Introduction	1-1
2. Siting criteria.....	2-1
2.1 Representativeness within an area	2-1
2.2 Representativeness with respect to topographic features.....	2-3
2.2.1 Technical facilities	2-3
2.2.2 Documentation.....	2-3
2.2.3 Distance between sites	2-4
2.3 References.....	2-4
3. Sampling methods.....	3-1
3.1 Precipitation amounts and determination of major ions in precipitation samples.....	3-1
3.1.1 Introduction.....	3-1
3.1.2 Principle	3-1
3.1.3 Site requirements	3-1
3.1.4 Sampling equipment	3-2
3.1.5 Sampling procedure	3-5
3.1.6 Chemical analyses.....	3-7
3.1.7 Calculation and reporting of results	3-8
3.1.8 Quality assurance	3-8
3.1.9 Special problems in precipitation sampling and analysis.....	3-10
3.1.10 References.....	3-11
3.2 Sampling of sulphur dioxide, sulphate, nitric acid, ammonia, nitrate and ammonium using the filter pack method.....	3-13
3.2.1 Introduction on the various sampling methods	3-13
3.2.2 Principle of using filter pack	3-14
3.2.3 Interference	3-14
3.2.4 Sampling equipment	3-15
3.2.5 Site requirements	3-17
3.2.6 Sampling procedure	3-18
3.2.7 Cleaning of filters	3-20
3.2.8 Impregnation of filters	3-22
3.2.9 Extraction from filters.....	3-24
3.2.10 Calculation of results	3-26
3.2.11 Quality assurance	3-27
3.2.12 References.....	3-28
3.3 Sampling of nitrogen dioxide.....	3-30
3.3.1 Determination of nitrogen dioxide using the iodide absorption method.....	3-31
3.3.1.1 Introduction	3-31
3.3.1.2 Principle.....	3-31
3.3.1.3 Sampling efficiency and interference	3-31
3.3.1.4 Sampling equipment.....	3-31
3.3.1.5 Commercial supply.....	3-33
3.3.1.6 Site requirements	3-33
3.3.1.7 Preparation of the absorption system.....	3-33
3.3.1.8 Sampling procedure.....	3-34
3.3.1.9 Preparation of samples and chemical analysis.....	3-34
3.3.1.10 Calculation of the air concentration.....	3-35
3.3.1.11 References	3-35

3.4	Sampling of sulphur dioxide, sulphate, nitric acid, ammonia, nitrate and ammonium using annular denuders	3-37
3.4.1.1	Introduction	3-37
3.4.1.2	Principle	3-37
3.4.1.3	Sampling equipment	3-37
3.4.1.4	Commercial supply	3-39
3.4.1.5	Site requirements	3-39
3.4.1.6	Sampling procedure	3-39
3.4.1.7	Preparation of samples for chemical analyses	3-40
3.4.1.8	Calculation of results	3-41
3.4.1.9	Quality assurance	3-41
3.4.1.10	Comments with respect to the denuder sampling procedure	3-42
3.4.1.11	References	3-42
3.5	Cleaning and impregnation of filters	3-43
3.6	Extraction from filters	3-43
3.7	Determination of light hydrocarbons in air	3-51
3.7.1	Introduction	3-51
3.7.2	Principle	3-51
3.7.3	Sampling equipment	3-51
3.7.4	Sampling procedure	3-51
3.7.5	Cleaning of canisters before the first use	3-51
3.7.6	Commercial supply	3-53
3.7.7	References	3-53
3.8	Determination of aldehydes and ketones in ambient air	3-54
3.8.1	Introduction	3-54
3.8.2	Principle	3-54
3.8.3	Sampling equipment	3-55
3.8.4	Commercial supply	3-55
3.8.5	Preparation of ozone-scrubber	3-55
3.8.6	Sampling procedure	3-58
3.8.7	Sampling handling	3-59
3.8.8	Procedure for blank sample preparation	3-59
3.8.9	References	3-59
3.9	Determination of ozone	3-60
3.9.1	Introduction	3-60
3.9.2	Field of application	3-60
3.9.3	Principle	3-60
3.9.4	Reagents and materials	3-61
3.9.5	Apparatus	3-61
3.9.5.1	UV photometric ambient ozone analyzer	3-61
3.9.5.2	Apparatus for calibration	3-63
3.9.5.3	Calibration of the ambient ozone analyzer	3-64
3.9.6	Cooperation with WMO GAW on surface ozone measurements	3-65
3.9.7	References	3-65
3.10	Sampling of heavy metals in precipitation	3-66
3.10.1	Introduction	3-66
3.10.2	Siting criteria	3-66
3.10.3	Sampling procedure	3-66
3.10.3.1	Equipment	3-66
3.10.3.2	Cleaning	3-67
3.10.3.3	Standard operating procedure	3-68
3.10.4	Conservation and filtering precipitation samples	3-69
3.10.4.1	Sample storage	3-69
3.10.4.2	Filtration of precipitation	3-70
3.10.5	Field blanks	3-70
3.10.6	Measuring the influence of dry deposition	3-70
3.10.7	Quality assurance	3-70
3.10.8	References	3-71

3.11	Sampling of heavy metals in particles	3-73
3.11.1	Introduction.....	3-73
3.11.2	Sampling equipment	3-73
3.11.2.1	The air sampler	3-73
3.11.2.2	Filters.....	3-74
3.11.3	Sampling procedure	3-74
3.11.4	Field blanks.....	3-74
3.11.5	Extraction from filters.....	3-75
3.11.6	Filter blanks	3-75
3.11.7	Calculation of results	3-75
3.11.8	Quality assurance.....	3-76
3.12	Sampling of mercury in precipitation and air	3-79
3.12.1	Introduction.....	3-79
3.12.2	Sampling methods for mercury in precipitation.....	3-79
3.12.2.1	Sampler design and materials.....	3-79
3.12.2.2	Washing procedure for glass equipment	3-80
3.12.2.3	Sampling procedure.....	3-81
3.12.2.4	Quality control – Quality assurance	3-82
3.12.2.5	Field blanks	3-82
3.12.2.6	Special problems	3-83
3.12.2.7	Summary.....	3-83
3.12.3	Sampling methods for total gaseous mercury in air.....	3-84
3.12.3.1	Sampler design and cleaning procedure	3-84
3.12.3.2	Sampling procedure.....	3-84
3.12.3.3	Sample storage.....	3-85
3.12.3.4	Volume standardisation.....	3-85
3.12.3.5	Quality control - Quality assurance	3-85
3.12.3.6	Special problems	3-86
3.12.3.7	Summary.....	3-86
3.12.4	Intercomparisons.....	3-86
3.12.5	Commercial supply	3-87
3.12.6	References.....	3-87
3.13	Sampling of persistent organic pollutants pesticides and PCBs	3-89
3.13.1	Principle.....	3-89
3.13.2	Equipment for air sampling	3-89
3.13.3	Sampling procedure	3-90
3.13.4	Weighing filters	3-91
3.13.5	Extracting samples.....	3-91
3.13.6	Cleaning of equipment.....	3-92
3.13.6.1	Cleaning of the sampler.....	3-92
3.13.6.2	Cleaning of PUF-plugs.....	3-92
3.13.6.3	Cleaning of glass equipment.....	3-92
3.13.6.4	Cleaning of other equipment	3-92
3.14	Sampling of polycyclic aromatic hydrocarbons (PAH) in air.....	3-93
3.14.1	Principle.....	3-93
3.14.2	Sampling equipment and instruments	3-93
3.14.3	Cleaning of equipment.....	3-93
3.14.3.1	Glass equipment	3-93
3.14.3.2	Glass fibre filter.....	3-93
3.14.3.3	Extraction timbles.....	3-93
3.14.3.4	Sampler.....	3-93
3.14.3.5	PUF-plugs.....	3-94
3.14.3.6	XAD-2	3-94
3.14.4	Sampling	3-94
3.14.5	Weighing filters	3-95
3.14.6	Extraction.....	3-95
3.14.7	Pre-concentration	3-95
3.15	Measurement of PM ₁₀ particles.....	3-96
3.15.1	Introduction.....	3-96

3.15.2	Sampling equipment.....	3-96
3.15.2.1	Impactor inlet.....	3-97
3.15.3	Filters.....	3-99
3.15.4	Interference.....	3-99
3.15.5	Sampling procedure.....	3-100
3.15.6	Maintenance and calibration.....	3-100
3.15.7	Weighing procedure.....	3-101
3.15.8	Filter blanks.....	3-101
3.15.9	Commercial supply.....	3-102
3.15.10	References.....	3-103
3.15.11	Measurements of PM _{2.5} and PM _{1.0}	3-103
3.15.11.1	List of Candidate CEN PM _{2.5} reference instruments.....	3-103
3.15.11.2	Manufactures with PM _{1.0} inlet.....	3-104
4.	Chemical analysis.....	4-1
4.1	Determination of sulphate, nitrate, chloride, ammonium, sodium, potassium, calcium, and magnesium with ion chromatography.....	4-1
4.1.1	Scope and Application.....	4-1
4.1.2	Principle.....	4-1
4.1.3	Interferences.....	4-1
4.1.4	Instrumentation.....	4-2
4.1.4.1	The Dionex (Dionex Corporation, Sunnyvale, CA, USA) system.....	4-2
4.1.4.2	The Waters (Waters Association, Milford, MA, USA) system.....	4-3
4.1.5	Reagents and standards.....	4-5
4.1.5.1	Eluent solutions.....	4-5
4.1.5.2	Stock standard solutions.....	4-5
4.1.5.3	Calibration solutions.....	4-6
4.1.6	Procedure.....	4-6
4.1.7	Calculation of the results.....	4-7
4.1.8	References.....	4-7
4.2	Determination of sulphate in precipitation.....	4-8
4.2.1	Spectrophotometric by the barium perchlorate-Thorin method.....	4-8
4.2.1.1	Field of application.....	4-8
4.2.1.2	Principle.....	4-8
4.2.1.3	Instrumentation.....	4-8
4.2.1.4	Chemicals.....	4-8
4.2.1.5	Reagents.....	4-9
4.2.1.6	Calibration.....	4-9
4.2.1.7	Analytical procedure.....	4-10
4.2.1.8	Interferences.....	4-10
4.2.1.9	References.....	4-10
4.2.2	Automatic Spectrophotometric by the barium perchlorate-Thorin method.....	4-10
4.2.2.1	Field of application.....	4-10
4.2.2.2	Principle.....	4-10
4.2.2.3	Instrumentation.....	4-11
4.2.2.4	Chemicals.....	4-11
4.2.2.5	Reagents.....	4-12
4.2.2.6	Calibration and analytical procedure.....	4-12
4.2.2.7	Expression of results.....	4-13
4.2.2.8	References.....	4-13
4.3	Determination of nitrate in precipitation.....	4-14
4.3.1	The manual spectrophotometric Griess method.....	4-14
4.3.1.1	Field of application.....	4-14
4.3.1.2	Principle.....	4-14
4.3.1.3	Instrumentation.....	4-14
4.3.1.4	Chemicals.....	4-14
4.3.1.5	Reagents.....	4-15
4.3.1.6	Calibration.....	4-15
4.3.1.7	Analytical procedure.....	4-16

4.3.1.8	References	4-16
4.3.2	Automatic spectrophotometric Griess method	4-16
4.3.2.1	Field of application	4-16
4.3.2.2	Principle	4-17
4.3.2.3	Instrumentation	4-17
4.3.2.4	Chemicals	4-18
4.3.2.5	Reagents	4-18
4.3.2.6	Calibration and analytical procedure	4-19
4.3.2.7	Expression of results	4-20
4.3.2.8	Interferences	4-20
4.3.2.9	References	4-20
4.4	Determination of ammonium in precipitation	4-21
4.4.1	Spectrophotometric by the indophenol blue method	4-21
4.4.1.1	Field of application	4-21
4.4.1.2	Principle	4-21
4.4.1.3	Instrumentation	4-21
4.4.1.4	Chemicals	4-21
4.4.1.5	Reagents	4-21
4.4.1.6	Calibration	4-22
4.4.1.7	Analytical procedure	4-22
4.4.1.8	Interferences	4-23
4.4.1.9	References	4-23
4.4.2	Automatic spectrophotometric determination of ammonium by the indophenol blue method	4-23
4.4.2.1	Field of application	4-23
4.4.2.2	Principle	4-23
4.4.2.3	Instrumentation	4-23
4.4.2.4	Chemicals	4-24
4.4.2.5	Reagents	4-24
4.4.2.6	Calibration and analytical procedure	4-25
4.4.2.7	Expression of results	4-26
4.4.2.8	Interferences	4-26
4.4.2.9	References	4-26
4.5	Determination of chloride in precipitation	4-27
4.5.1	Spectrophotometric mercury thiocyanate-iron method	4-27
4.5.1.1	Field of application	4-27
4.5.1.2	Principle	4-27
4.5.1.3	Instrumentation	4-27
4.5.1.4	Chemicals	4-27
4.5.1.5	Reagents	4-27
4.5.1.6	Calibration	4-28
4.5.1.7	Analytical procedure	4-28
4.5.1.8	Interferences	4-28
4.5.1.9	References	4-28
4.6	Determination of sodium, potassium, magnesium, and calcium in precipitation	4-29
4.6.1	Determination by flame atomic spectroscopy (AAS or AES)	4-29
4.6.1.1	Field of application	4-29
4.6.1.2	Principle	4-29
4.6.1.3	Interferences	4-29
4.6.1.4	Instrumentation	4-29
4.6.1.5	Chemicals	4-30
4.6.1.6	Reagents	4-30
4.6.1.7	Calibration solutions and stock solutions	4-30
4.6.1.8	Calibration of the instrument	4-31
4.6.1.9	Analytical procedure	4-31
4.7	Determination of pH in precipitation	4-32
4.7.1	Potentiometric method	4-32
4.7.1.1	Principle	4-32

4.7.1.2	Instrumentation	4-33
4.7.1.3	Chemicals.....	4-33
4.7.1.4	Reagents.....	4-33
4.7.1.5	Calibration.....	4-34
4.7.1.6	Analytical procedure.....	4-34
4.7.1.7	Performance test of the electrode pair.....	4-34
4.7.2	References	4-34
4.8	Determination of strong and weak acids in precipitation	4-36
4.8.1	Coulometric titration method	4-36
4.8.1.1	Field of application	4-36
4.8.1.2	Principle	4-36
4.8.1.3	Instrumentation	4-36
4.8.1.4	Chemicals and reagents.....	4-37
4.8.1.5	Analytical procedure.....	4-37
4.8.1.6	Expression of results.....	4-39
4.8.1.7	References.....	4-39
4.8.2	Coulometric titration of strong acid by means of an instrument for automatic plotting of Gran's function	4-40
4.8.2.1	Field of application	4-40
4.8.2.2	Principle	4-40
4.8.2.3	Instrumentation	4-40
4.8.2.4	Chemicals and reagents.....	4-43
4.8.2.5	Calibration.....	4-43
4.8.2.6	Analytical procedure.....	4-43
4.8.2.7	Expression of results.....	4-44
4.9	Determination of conductivity.....	4-46
4.9.1	Principle	4-46
4.9.2	Instrumentation.....	4-46
4.9.3	Chemicals	4-46
4.9.4	Calibration solutions.....	4-47
4.9.5	Calibration of the instrument.....	4-47
4.9.6	Measurement procedure	4-47
4.9.7	Maintenance and storage of measurement cell.....	4-48
4.10	Determination of sulphur dioxide as sulphate ions on impregnated filters	4-49
4.10.1	Determination of sulphur dioxide as sulphate by ion chromatography.....	4-49
4.10.2	Determination of sulphur dioxide as sulphate spectrophotometric by the barium perchlorate – Thorin method.....	4-49
4.10.2.1	Field of application	4-49
4.10.2.2	Principle	4-49
4.10.2.3	Instrumentation	4-49
4.10.2.4	Chemicals.....	4-49
4.10.2.5	Reagents.....	4-49
4.10.2.6	Calibration.....	4-49
4.10.2.7	Analytical procedure.....	4-49
4.10.2.8	Expression of results.....	4-50
4.10.2.9	References.....	4-50
4.11	Determination of nitrogen dioxide as nitrite.....	4-51
4.11.1	Determination of nitrite in extracts from impregnated glass sinters.....	4-51
4.11.1.1	Scope and application	4-51
4.11.1.2	Principle	4-51
4.11.1.3	Instrumentation	4-51
4.11.1.4	Chemicals.....	4-51
4.11.1.5	Reagents and solutions.....	4-52
4.11.1.6	Analytical procedure.....	4-52
4.12	Determination of nitric acid and ammonia absorbed on impregnated filters.....	4-53
4.12.1	Determination of nitrate ions by ion chromatography.....	4-53
4.12.2	Spectrophotometric determination of nitric acid by reduction to nitrite and reaction with sulphanilic acid.....	4-53

4.12.3	Automatic spectrophotometric determination of nitric acid by reduction to nitrite and reaction with sulphanilic acid	4-53
4.12.4	Determination of ammonium ions by ion chromatography	4-53
4.12.5	Spectrophotometric determination of ammonia as ammonium by the indophenol blue method.....	4-53
4.12.6	Automatic spectrophotometric determination of ammonia as ammonium by the indophenol blue method.....	4-53
4.13	Determination of sulphate in aerosol filters	4-54
4.13.1	Determination of sulphate ions by ion chromatography	4-54
4.13.2	Determination of sulphate spectrophotometric by the barium perchlorate – Thorin method.....	4-54
4.13.2.1	Field of application	4-54
4.13.2.2	Principle.....	4-54
4.13.2.3	Instrumentation.....	4-54
4.13.2.4	Chemicals	4-54
4.13.2.5	Reagents	4-54
4.13.2.6	Calibration	4-54
4.13.2.7	Analytical procedure	4-54
4.13.2.8	Expression of results	4-54
4.14	Determination of nitrate and ammonium in aerosol filters	4-55
4.14.1	Determination of nitrate ions by ion chromatography	4-55
4.14.2	Spectrophotometric determination of nitrate by reduction to nitrite and reaction with sulphanilic acid	4-55
4.14.3	Automatic spectrophotometric determination of nitrate by reduction to nitrite and reaction with sulphanilic acid	4-55
4.14.4	Determination of ammonium ions by ion chromatography	4-55
4.14.5	Spectrophotometric determination of ammonium by the indophenol blue method	4-55
4.14.6	Automatic spectrophotometric determination of ammonium by the indophenol blue method.....	4-55
4.15	Determination of light hydrocarbons	4-56
4.15.1	Instrumentation	4-56
4.15.1.1	VOC air analyser (Chrompack, Middelburg, The Netherlands).....	4-56
4.15.1.2	Gas chromatography (GC 9000 Chrompack).....	4-57
4.15.1.3	Gases and materials	4-57
4.15.2	Analytical Procedure.....	4-57
4.15.3	Quality assurance.....	4-57
4.15.3.1	Calibration	4-57
4.15.3.2	Maintenance	4-58
4.15.4	References.....	4-58
4.16	Determination of aldehydes and ketones in ambient air	4-64
4.16.1	Instrumentation	4-64
4.16.1.1	Chemicals	4-64
4.16.2	Analytical procedure.....	4-64
4.16.3	Blanks	4-65
4.16.4	Preparation of hydrazones	4-65
4.16.5	Calibration	4-65
4.16.6	Quantification	4-66
4.16.7	Interferences.....	4-66
4.16.8	References.....	4-66
4.17	Analytical methods for determination of heavy metals	4-67
4.17.1	Introduction.....	4-67
4.17.2	Washing procedures.....	4-68
4.17.3	Determination of Cd, Pb, Cu, Zn, Cr, Ni and As by the use of inductively coupled plasma mass spectrometry (ICP-MS).....	4-68
4.17.3.1	Introduction	4-68
4.17.3.2	Principles	4-69
4.17.3.3	Interferences	4-69
4.17.3.4	Calibration and standardisation	4-73

4.17.4	Determination of Cd, Pb, Cu, Zn, Cr, Ni and As by the use of graphite furnace atomic absorption spectroscopy (GF-AAS)	4-75
4.17.4.1	Introduction	4-75
4.17.4.2	Principles	4-75
4.17.4.3	Interference	4-76
4.17.4.4	Instrumentation	4-76
4.17.4.5	Reagents and standards	4-77
4.17.4.6	Instrument procedure	4-78
4.17.4.7	Setting up a temperature programme	4-79
4.17.4.8	Instrument performance	4-79
4.17.4.9	Chemical modifiers	4-80
4.17.4.10	Sequence of analysis	4-80
4.17.5	Determination of zinc by flame atomic absorption spectroscopy (F-AAS)	4-81
4.17.5.1	Introduction	4-81
4.17.5.2	Principles	4-81
4.17.5.3	Interferences	4-81
4.17.5.4	Instrumentation	4-82
4.17.5.5	Reagents and standards	4-82
4.17.5.6	Instrumental procedure	4-83
4.17.5.7	Instrument performance	4-83
4.17.5.8	Sequence of analysis	4-83
4.17.6	References	4-84
4.18	Analysis of mercury in precipitation and air	4-85
4.18.1	Analysis of mercury in precipitation	4-85
4.18.1.1	Instrumentation	4-85
4.18.1.2	Sample storage and handling	4-85
4.18.1.3	Chemicals and glassware	4-85
4.18.1.4	Pre-treatment	4-86
4.18.1.5	Preparation of reducing vessels	4-87
4.18.1.6	Reduction step	4-87
4.18.1.7	Detection	4-87
4.18.1.8	Calibration	4-87
4.18.1.9	Quality control - Quality assurance	4-88
4.18.1.10	Special problems	4-88
4.18.1.11	Summary	4-88
4.18.2	Analysis of mercury in air	4-88
4.18.2.1	Sample pre-treatment	4-88
4.18.2.2	Analysis	4-89
4.18.2.3	Calibration	4-89
4.18.2.4	Quality assurance	4-90
4.18.2.5	Detection limit	4-90
4.18.2.6	Special problems	4-91
4.18.2.7	Summary	4-91
4.18.3	References	4-91
4.19	Determination of persistent organic pollutants (pesticides and PCBs)	4-93
4.19.1	Principle	4-93
4.19.2	Materials and equipment	4-93
4.19.2.1	Glassware	4-93
4.19.2.2	Other equipment	4-94
4.19.2.3	Analytical equipment and accessories	4-94
4.19.2.4	Chemicals and gases	4-95
4.19.3	Cleaning and pre-treatment	4-96
4.19.3.1	Cleaning of the sampler	4-96
4.19.3.2	Cleaning of PUF-plugs	4-96
4.19.3.3	Cleaning of glass equipment	4-96
4.19.3.4	Cleaning of other equipment	4-96
4.19.3.5	Check and pre-treatment of solvents and chemicals	4-96
4.19.3.6	Cleaning of diethyl ether	4-96
4.19.3.7	Pre-treatment of sodium sulphate	4-96

4.19.3.8	Pre-treatment of silica.....	4-97
4.19.3.9	Cleaning of soxhlet thimbles.....	4-97
4.19.3.10	Cleaning of cotton wool.....	4-97
4.19.4	Gas cleaning.....	4-97
4.19.4.1	Gas bottle exchange.....	4-97
4.19.5	Special procedures.....	4-98
4.19.6	Treatment of adsorbents.....	4-98
4.19.7	Sample preparation.....	4-98
4.19.7.1	Principle.....	4-98
4.19.7.2	Sulphuric acid treatment of acid-stable substances.....	4-98
4.19.7.3	Alkaline hydrolysis of acid-labile substances.....	4-99
4.19.7.4	Silica chromatography.....	4-99
4.19.7.5	If the sample contains silica particles.....	4-99
4.19.8	Standards.....	4-99
4.19.8.1	Concentrated standard.....	4-101
4.19.8.2	Calibration standard.....	4-102
4.19.8.3	Internal standard (ISTD).....	4-102
4.19.8.4	Recovery standard (RSTD).....	4-102
4.19.8.5	Standard addition.....	4-102
4.19.8.6	Quality assurance of standards.....	4-102
4.19.9	Separation and quantification.....	4-102
4.19.9.1	Principle.....	4-102
4.19.9.2	Gas chromatographic conditions.....	4-103
4.19.9.3	GC/MS-analysis.....	4-104
4.19.10	Calibration of instruments.....	4-108
4.19.10.1	Control of concentrations of standards.....	4-108
4.19.10.2	Frequency of GC injections of quantification standard.....	4-109
4.19.10.3	Analysis of control samples.....	4-109
4.19.11	Recovery test.....	4-109
4.19.12	Quality assurance.....	4-109
4.19.12.1	General principles.....	4-109
4.19.12.2	Administrative routines.....	4-110
4.19.12.3	Sample journal.....	4-110
4.19.12.4	Sample handling form.....	4-110
4.19.12.5	Instrument logbook.....	4-111
4.19.12.6	Standard journal.....	4-111
4.19.12.7	Acceptance of results.....	4-111
4.19.12.8	Reporting of results.....	4-111
4.19.12.9	Storage.....	4-112
4.19.12.10	Validation of the method.....	4-112
4.19.12.11	Testing of blank values.....	4-112
4.19.12.12	Participation in laboratory intercomparisons.....	4-113
4.19.13	Reference.....	4-113
4.20	Determination of polycyclic aromatic hydrocarbons (PAHs) in air.....	4-114
4.20.1	Introduction.....	4-114
4.20.2	Equipment and instruments.....	4-114
4.20.2.1	Gas chromatography/mass spectrometry (GC/MS).....	4-114
4.20.2.2	Liquid chromatograph.....	4-114
4.20.2.3	Soxhlet equipment.....	4-114
4.20.2.4	Glass equipment.....	4-115
4.20.2.5	Other equipment.....	4-115
4.20.3	Chemicals and gases.....	4-115
4.20.4	Cleaning of equipment and chemicals.....	4-116
4.20.4.1	Glass equipment.....	4-116
4.20.4.2	Glass fibre filter.....	4-116
4.20.4.3	Extraction thimbles.....	4-116
4.20.4.4	Sampler.....	4-116
4.20.4.5	Sodium sulphate.....	4-116
4.20.4.6	PUF-plugs.....	4-116

4.20.4.7	Drying	4-117
4.20.4.8	XAD-2	4-117
4.20.5	Gas cleaning	4-117
4.20.5.1	Gas bottle exchange	4-117
4.20.5.2	Special procedures	4-117
4.20.6	Treatment of adsorbents	4-118
4.20.7	Analysis	4-118
4.20.7.1	Adding internal standards	4-118
4.20.7.2	Clean-up	4-118
4.20.7.3	Sample clean-up using HPLC	4-119
4.20.7.4	Cleaning of the column	4-120
4.20.8	Calibration and quantification	4-120
4.20.8.1	PAH-standards	4-120
4.20.8.2	Main standard	4-122
4.20.8.3	Internal standards	4-122
4.20.8.4	Recovery standard	4-123
4.20.8.5	Quantification standard	4-123
4.20.8.6	Control standard	4-123
4.20.8.7	Retention standard, HPLC	4-124
4.20.9	Separation and quantification	4-124
4.20.9.1	GC separation	4-124
4.20.9.2	Mass spectrometry (MS)	4-124
4.20.9.3	Quantification	4-126
4.20.9.4	GC/MS-analysis	4-127
4.20.9.5	Detection limit	4-127
4.20.10	Quality assurance	4-128
4.20.10.1	Reception and storage of samples	4-128
4.20.10.2	Standard mixtures	4-128
4.20.10.3	Control standard	4-128
4.20.10.4	Recovery of internal standard	4-128
4.20.10.5	Blanks	4-129
4.20.10.6	Control of results	4-129
4.21	Chemical speciation	4-130
4.21.1	Introduction	4-130
4.21.2	Extraction	4-130
4.21.3	Determination of the inorganic components	4-130
4.21.4	Determination of heavy metals	4-131
4.21.5	EC/OC determination	4-131
4.21.6	Chemical characterization of the OC fraction	4-132
4.21.7	Analysis of mineral dust	4-133
4.21.8	References	4-135
5.	Quality assurance	5-1
5.1	Job description for EMEP's National Quality Assurance Manager	5-2
5.2	EMEP Data Quality Objectives (DQO)	5-3
5.2.1	DQO for the acidifying and eutrophying compounds	5-3
5.2.2	DQO for heavy metals	5-4
5.3	Quality Assurance Plan	5-4
5.4	Measurement sites	5-5
5.4.1	Information about a monitoring site	5-5
5.5	Field and laboratory operations	5-6
5.5.1	Common guidelines for field and laboratory activities	5-6
5.5.1.1	Audits	5-6
5.5.2	Field operations	5-7
5.5.2.1	Instrumentation	5-7
5.5.2.2	Changing of samples at the site	5-8
5.5.2.3	Sample storage and transportation	5-8
5.5.2.4	Field blanks	5-8
5.5.2.5	Comparison of different field instruments	5-9

5.5.2.6	Precision of field instruments and measurement systems.....	5-10
5.5.3	Laboratory operations.....	5-10
5.5.3.1	Chemical analysis.....	5-10
5.6	Determination of accuracy.....	5-11
5.6.1	Determination of systematic errors.....	5-11
5.6.2	Determination of precision.....	5-13
5.6.3	Calculation example for precision.....	5-14
5.7	Calculation of detection limit.....	5-18
5.7.1	Basic assumption.....	5-18
5.7.2	Statistical considerations.....	5-19
5.7.2.1	Data distribution.....	5-19
5.7.2.2	Detection limit.....	5-19
5.7.2.3	Winsorization procedure.....	5-20
5.7.3	Calculation example for air samples.....	5-20
5.8	Training of personnel.....	5-22
5.8.1	Training of station personnel.....	5-22
5.8.2	Training of laboratory personnel.....	5-22
5.9	References.....	5-23
6.	Data handling and data reporting.....	6-1
6.1	Data checking.....	6-1
6.1.1	Statistical tests.....	6-1
6.1.2	Ion balance.....	6-2
6.1.3	Conductivity.....	6-3
6.1.4	Calculation of ion balance and conductivity.....	6-3
6.1.5	Use of time series plots in data checking.....	6-5
6.1.6	Other methods for data check.....	6-6
6.2	Rejection of data.....	6-7
6.3	Classification of precipitation samples.....	6-8
6.4	Data flags.....	6-9
6.4.1	Group 9: Missing.....	6-9
6.4.2	Group 8: Undefined.....	6-10
6.4.3	Group 7: Value unknown.....	6-10
6.4.4	Group 6: Mechanical problem.....	6-10
6.4.5	Group 5: Chemical problem.....	6-11
6.4.6	Group 4: Extreme or inconsistent values.....	6-11
6.4.7	Group 3.....	6-12
6.4.8	Group 2: Exception flags assigned by the database co-ordinator.....	6-12
6.4.9	Group 1: Exception flags for accepted, irregular data.....	6-13
6.4.10	Group 0.....	6-13
6.5	Data reporting.....	6-14
6.6	References.....	6-15

EMEP manual for sampling and chemical analysis

1. Introduction

The “Cooperative programme for monitoring and evaluation of long-range transmission of air pollutants in Europe” (EMEP) was launched in 1977 as a response to the growing concern over the effects on the environment caused by acid deposition. EMEP was organized under the auspices of the United Nations Economic Commission for Europe (ECE). Today EMEP is an integral component of the cooperation under the Convention on Long-range Transboundary Air Pollution.

The main objective of EMEP is to provide governments with information on deposition and concentration of air pollutants, as well as on the quantity and significance of long-range transmission of pollutants and transboundary fluxes. The programme includes three main elements: emission data, measurements of air and precipitation quality, and atmospheric dispersion models. The work is co-ordinated by three international centres: two centres for modelling activities and one Chemical Co-ordinating Centre (CCC) for coordination of the chemical measurements.

This manual describes the standard recommended methods for sampling and chemical analysis for the EMEP measurement network. The methods and procedures are generally derived from the development and experience gained within EMEP as well as information provided by similar programmes in North America, World Meteorological Organization, various research programmes and numerous EMEP workshops.

The measurements within EMEP are carried out by national laboratories, reporting the results to a common data base at the CCC. Experience has shown that measurements should be standardized as much as possible to obtain data which are comparable and of sufficient quality to allow meaningful comparisons with model calculations, calculation of trends and other statistical evaluations. In addition, quality assurance has to be carried out on both the national level and by the CCC to ensure satisfactory data quality. This applies both to individual samples and particularly to long-term aggregated values, such as seasonal or yearly mean values and trends. It is particularly important to avoid errors which may result in systematically too low or too high results, and undefined changes in the data quality over time, which may cause problems in trend analyses.

For the majority of the methods, the necessary quality assurance is facilitated by a combination of simple and robust sampling techniques with well-described sampling equipment, and use of synthetic control samples for the chemical analyses.

The representativity of a site is a highly relevant question for a measurement network such as EMEP. This can only be determined in relation to the purpose of the measurements. For EMEP the site must be positioned in such a way that the air quality and the precipitation is representative of a larger region. In order for the site to be representative, influences and contamination from local sources must be avoided.

During the period of EMEP operations, considerable improvements have taken place with respect to the development of instrumentation for chemical analysis.

EMEP's measurement programme and recommended methods described in the manual

Components	Measurement period	Measurement frequency	Sampling methods in field	Methods in laboratory
Gas				
SO ₂	24 hours	daily	KOH impregnated filters	IC / (Thorin)
NO ₂	24 hours	daily	Nal impregnated glass frit	IC / Griess
O ₃	hourly means stored	continuously	UV absorption	
HNO ₃	24 hours	daily	denuder	IC / Griess after reduction
NH ₃	24 hours	daily	denuder	IC / Indophenol
Light hydrocarbons C2-C7	10-15 mins	twice weekly	steel canisters	GC
Ketones and aldehydes (VOC)	8 hours	twice weekly	DNPH cartridge	HPLC
Hg	24 hours	weekly	Gold traps	CV-AFS
Particles				
SO ₄ ²⁻	24 hours	Daily	aerosol filter	IC / (Thorin)
NO ₃ ⁻	24 hours	Daily	aerosol filter after denuder	IC / Griess after reduction
NH ₄ ⁺	24 hours	Daily	aerosol filter after denuder	IC / Indophenol
Na ⁺ , Mg ²⁺ , Ca ²⁺ , K ⁺ , Cl ⁻	24 hours	Daily	aerosol filter	IC / AAS / AES
PM ₁₀	24 hours	Daily	EN 12341	micro balance
PM _x	24 hours	Daily	To be decided	micro balance
Mineral dust	24 hours	Daily	EN 12341	INAA, PIXE, XRF
EC and OC	24 hours	Daily	EN 12341	Thermo desorption and oxidation
OC-speciation	24 hours	once a week	EN 12341	LC-MS
Cd, Pb (first priority), Cu, Zn, As, Cr, Ni (second priority)	weekly	weekly	EN 12341	ICP-MS / GF-AAS
Gas + particles				
HNO ₃ (g)+NO ₃ ⁻ (p),	24 hours	daily	Filter pack	IC / Griess after reduction
NH ₃ (g)+NH ₄ ⁻ (p)	25 hours	daily	Filter pack	IC / Indophenol
POPs (PAH, PCB, HCB, chlordane, lindane, a-HCH, DDT/DDE)	to be decided	to be decided	PUF (polyurethane foam) sampler	GC-MS

Components	Measurement period	Measurement frequency	Sampling methods in field	Methods in laboratory
Precipitation				
Amount	24 hours (weekly)	daily (weekly)	rain gauge	By weight
SO ₄ ²⁻	24 hours (weekly)	daily (weekly)	wet only	IC
H ⁺	24 hours (weekly)	daily (weekly)	wet only	titration
pH	24 hours (weekly)	daily (weekly)	wet only	pH meter
NH ₄ ⁺	24 hours (weekly)	daily (weekly)	wet only	IC / Indophenol
NO ₃ ⁻	24 hours (weekly)	daily (weekly)	wet only	IC / Griess after reduction
Na ⁺	24 hours (weekly)	daily (weekly)	wet only	IC / AES
Mg ²⁺	24 hours (weekly)	daily (weekly)	wet only	IC / AAS
Cl ⁻	24 hours (weekly)	daily (weekly)	wet only	IC / Thiocyanate
Ca ²⁺	24 hours (weekly)	daily (weekly)	wet only	IC / AAS
K ⁺	24 hours (weekly)	daily (weekly)	wet only	IC / AES
κ (conductivity)	24 hours (weekly)	daily (weekly)	wet only	Cond-meter
Cd, Pb (first priority)	weekly	weekly	wet-only	ICP-MS / GF-AAS
Cu, Zn, As, Cr, Ni (second priority)	weekly	weekly		
Hg ²⁺	weekly (1 sampler) (or monthly (2 samplers))	weekly (or monthly)	wet only IVL sampler	CV-AFS
POPs (PAH, PCB, HCB, chlordane, lindane, a-HCH, DDT/DDE)	to be decided	to be decided	wet-only	

2. Siting criteria

2.1 Representativeness within an area

The site chosen for sampling and measurements should be representative of a larger area. The size of this area is determined by the variability of the air and precipitation quality, and the desired spatial resolution in the concentration and deposition fields. Urban and industrial areas, and the areas immediately outside such areas are not to be included, because these make up a very small fraction of the total area covered by EMEP, and the higher concentrations in such areas are caused by national emissions. The purpose of EMEP is to provide Parties with information on the deposition and concentration of air pollutants, as well as on the quantity and significance of the long-range transmission of pollutants and fluxes across national boundaries.

The size of the site's area of representativeness should be larger than the size resolution of the atmospheric dispersion models which are available for the evaluation of the long-range transmission and deposition of air pollutants. EMEP models and emission surveys have up to now employed a grid sizes of 150*150 km², this spatial resolution is now being improved to 50*50 km² in some models.

When the major part of the emissions influencing the air quality in an area are situated outside that area, selection of the site involves mainly consideration of the effects of the immediate surroundings and emissions within the nearest 20 km. These local emissions should not be allowed to result in unrepresentative measured air concentrations or precipitation chemistry at the site, which means that their influence must be evaluated and compared with the measurements. In practice, emissions of sulphur dioxide and nitrogen dioxide within the nearest 100 m should be avoided, emissions within the nearest 2 km should be less than 100 kg/year, and emissions within the nearest 20 km less than 1000 kg/year. In addition, consideration of local meteorological conditions, such as prevailing wind directions and formation of stagnant air should be considered.

The situation is more complicated if the site is located within an area of major emissions. In principle, the representativeness of a particular site within such an area can be determined by the use of models, provided that the models are adequate and the emissions and the meteorology are known in adequate detail. Since the distribution of emissions is uneven, the distributions of ambient concentrations at ground level are skewed, with median concentrations typically less than the area mean values. Variations in airborne concentrations within a given grid are caused by both short-term random fluctuations in the meteorological parameters responsible for dispersion and advection, by deposition processes and interactions with the surface, and by differences in the exposure towards dominating emissions in the long term. Seilkop (1994) used daily measured values for clusters of 3-5 neighbouring sites in 6 areas of the eastern USA to determine 95% confidence limits for these values, assuming that these reflect the spatial representativeness of the sites. As could be expected, for areas where the main source of sulphur dioxide is emissions from large power plants, daily variabilities were quite high for sulphur dioxide. In this situation no single site can

be expected to reflect an area mean value on a day-to-day basis. Other papers presented at the EMEP-WMO workshop in Passau (EMEP/CCC-Report 2/94) also show the difficulty in explaining or predicting individual high concentrations at individual sites on a daily basis by existing models. However, on a more long-term basis, inter-grid variabilities are generally much smaller. Sites within areas with large emission sources should therefore be expected to be representative only on a monthly or yearly averaging period.

Representativeness is more readily achieved for secondary pollutants such as sulphate aerosol and ozone.

Ammonia is a special problem, since the emissions are mainly linked with animal husbandry and agricultural activities. Stabling of animals, storage and application of manure, and grazing of fertilized pasture by cattle, are important emission sources, and should be avoided in the nearest surroundings of the site.

For precipitation, local emission sources of sulphur dioxide or nitrogen oxides are generally of less importance, but sources of dust and ammonia should be avoided. Even if a wet-only precipitation collector is used, a dusty environment may cause serious contamination problems.

Guidelines specifying minimum distances to emission sources have been given in the EMEP Quality Assurance Plan (Schaug, 1988). These were based on similar guidelines from North American monitoring programmes. Table 2.1.1 sums up these recommendations:

Table 2.1.1: Minimum distance to emission and contamination sources.

Type	Minimum distance	Comment
Large pollution sources (towns, power plants, major motorways)	50 km	Depending on prevailing wind directions
Small scale domestic heating with coal, fuel oil or wood	100 m	Only one emission source at minimum distance
Minor roads	100 m	Up to 50 vehicles/day
Main roads	500 m	Up to 500 vehicles/day
Application of manure, stabling of animals.	2 km	Depending on the number of animals and size of fertilized field or pastures
Grazing by domestic animals on fertilized pasture	500 m	Depending on the number of animals and size of fertilized field or pastures

The distances given in this table should be taken only as indicative, an appraisal of local emissions' influence on the air and precipitation chemistry at the site must be made on the basis of considerations of meteorological and topographic conditions, and the estimated emissions from the activities mentioned above.

2.2 Representativeness with respect to topographic features

The site must be representative also with respect to exposure to the air mass. Valleys or other locations which are subject to formation of stagnant air under inversion conditions should be avoided, also mountaintops and passes (cols). The ideal is a well exposed site in moderately undulating terrain, or, if valleys cannot be avoided, on the side of the valley above the most pronounced night-time inversion layer. Coastal sites with pronounced diurnal wind variations due to land-sea breeze effects are also not recommended. Vegetation is a sink for many air pollutants, and it is important to avoid situations where sheltering by vegetation, e.g. by a stand of trees, results in lowered concentration when the wind is blowing from a particular direction.

The choice of a site, and the proper location of the precipitation collector is also important in order to ensure that the precipitation samples are representative for precipitation over a larger area. The collector should not be exposed to strong winds, but should also not be sheltered by tall trees or buildings. The annual precipitation amount at the site, as measured by an ordinary meteorological precipitation gauge, should not differ markedly from the precipitation amounts at adjacent sites in the national precipitation network, and the daily precipitation amounts should also be correlated with those from the adjacent sites.

The location of the sampler should conform to WMO site requirements for precipitation gauges (WMO, 1971). There should be no obstacles, such as trees, above 30° from the rim of the precipitation collector, and buildings, hedges, or topographical features which may give rise to updraughts or downdraughts should be avoided. Consideration of the prevailing wind directions during precipitation events is recommended in connection with locating the sampler.

Of particular concern is potential contamination from sedimentation of soil dust particles from the immediate surroundings. Gravel roads, farmyards, and tilled agricultural fields within a distance of 100 m to 1 km should be avoided. The ground cover should preferably be short grass.

2.2.1 *Technical facilities*

Air sampling and monitoring equipment requires a small building, or shed, and supply of electricity. The room containing pumps and control units should preferably be kept at approximately 20°C. A refrigerator must also be available for storage of samples. A telephone line is useful for the transfer of ozone measurement data via a modem from a data logger. Access to the site by car should be limited to the persons directly in charge of the sampling and the measurements.

2.2.2 *Documentation*

The land use, and the topography of the immediate surroundings, and preferably also the meteorological conditions (wind rose, climatological data) should be available in the form of maps, tables and diagrams.

An inventory of emissions in the nearest 20 km is also required.

In order to evaluate the representativeness of the site, information on the air quality and deposition for several sites within the same area is generally required. Such information may be provided by detailed mathematical modelling if the sources of air pollutants are known in sufficient detail. Another possibility is to run measurements at several sites for a limited time period. Simple and relatively inexpensive measurement techniques are now available for the determination of long-term average concentrations of sulphur dioxide, nitrogen dioxide and ammonia, using passive samplers. For precipitation, weekly or even monthly sample collection at a number of sites within the same area will serve to determine the representativeness of the chosen site.

2.2.3 Distance between sites

The maximum distance between adjacent sites within the EMEP network should be carefully considered. This again depends on the size resolution of the models which are being used, and the spatial gradients in the concentration fields which are due to large-scale transport, transformation and deposition effects.

The (spatial) correlation between measured concentrations of air pollutants in Europe is highly anisotropic, and depends on the position and strength of emission sources, wind directions, topography and the chemical and physical properties of the various pollutants. An recent evaluation by the EMEP Bureau recommended a distance between the sites of 150–200 km in central parts of Europe, and about 300 km in areas which are mainly influenced by emissions more than 500 km away. Spatial covariance analyses of annual average concentration values give rather variable ranges of covariance from one year to another, but the range is usually 300–600 km.

2.3 References

WMO (1971) Guide to meteorological instrument and observing practices.

Geneva, World Meteorological Organization (WMO No. 8 TP 3).

Seilkop, S.V. (1994) Representativeness of surface site air concentrations relative to an 80 km grid. To appear in Proceedings of the conference on regional photochemical measurement and modeling studies.

Berge, E., Schaug, J., Sandnes, H. and Kvalvågnes, I. (1994) A comparison of results from the EMEP/MSC-W acid deposition model and the EMEP monitoring sites during the four seasons of 1989. In: *EMEP Workshop on the Accuracy of Measurements. Passau 1993*. Edited by T. Berg and J. Schaug. Kjeller, Norwegian Institute for Air Research (EMEP/CCC-Report 2/94). pp. 209–266.

EMEP(1994) The status of monitoring within EMEP: Distribution of monitoring sites and implementation of measurement programme. Note by the Bureau (EB.AIR/GE.1/R.90).

3. Sampling methods

3.1 Precipitation amounts and determination of major ions in precipitation samples

3.1.1 Introduction

The purpose of sampling and chemical analysis of precipitation in the EMEP network is generally to give an accurate indication of precipitation chemical composition, which can be used to derive deposition by scaling with precipitation amounts, both on short-term (day-month) and on long-term bases.

In connection with the determination of transboundary fluxes and deposition of air pollutants, the concentrations of sulphate, ammonium and nitrate in precipitation are particularly important. However, determination of one or more of the sea-salt constituents (Na, Cl, Mg) is also necessary in order to determine the fraction of sulphate concentration which is due to marine sea-spray aerosols; and determination of the base cations Ca, K, and Mg is desirable in order to give an indication of the large-scale deposition of bases which is needed in connection with the determination of critical loads.

Finally, pH and conductivity should also be determined in order to give an indication of the overall composition of the samples, and to check the consistency of the chemical analyses.

3.1.2 Principle

Precipitation is collected in a vessel, with a defined horizontal opening. The collecting vessel must be constructed from a material, which does not alter the chemical composition of the sample, and shall give a reliable measure of the amount of precipitation on a daily basis. The concentration of the major anions and cations are determined by chemical analysis.

3.1.3 Site requirements

In order for the measurements to be useful for validation of models of long-range transport and deposition of air pollutants the site for precipitation collection should be chosen, and the collection of rain and snow for analyses should be made in such a way that the concentrations are representative of rainfall composition over a larger area. For this purpose, the following requirements have been worked out:

1. The annual precipitation amount at the site, as measured by an ordinary meteorological precipitation gauge, should not differ markedly from the precipitation amounts at adjacent sites in the national precipitation network, and the daily precipitation amounts should also be correlated with those from the adjacent sites.
2. The location of the sampler should conform to WMO site requirements for precipitation gauges (WMO, 1971). There should be no obstacles, such as trees, above 30° from the rim of the precipitation collector, and buildings, hedges, or topographical features which may give rise to updraughts or

downdraughts should be avoided. Consideration of the prevailing wind directions during precipitation events is recommended in connection with locating the sampler.

3. Of particular concern is the sedimentation of soil dust particles from the immediate surroundings. Gravel roads, farmyards, and tilled agricultural fields in the near surroundings within a distance of 100 m to 1 km should be avoided. Other potential local contamination sources include local residential heating with wood, peat or coal. Potassium is an indicator of such contamination. Local high ammonia concentrations from farming activities should also be avoided.

Supply of electricity is necessary for the operation of wet-only precipitation samplers. For the operation of the sampling site a small room is needed to store samples, equipment, and documents. This must be equipped with a refrigerator for the storage of collected precipitation samples.

3.1.4 *Sampling equipment*

The sampling equipment consists in principle of a funnel and a receiving vessel, as indicated on Figure 3.1.1. In order for the sample not to be contaminated from the ground during heavy rain, the rim of the funnel should be positioned 1.5–2 m above the ground level. It is recommended that the sampler be further protected from sedimentation of dust and adsorption of gases during dry periods by an automatic lid, which opens after activation of a precipitation sensor. The precipitation sensor is usually based on measuring the electrical conductivity between a pair of gold-plated electrodes on a suitable non-conducting surface. The sensor is electrically heated to a temperature of 1–2 degrees above the ambient temperature so that the water film evaporates after the precipitation event. The sensitivity of the sensor is important, a precipitation amount of 0.05 mm/h should be sufficient for the lid opening mechanism to be activated.

Precipitation collectors are commercially available and a list of instruments and manufacturers' addresses is given below (Table 3.1.1). In selecting one of these, reference should be made to available field test results (e.g. Winkler et al., 1989; Granat et al., 1993), and the climatic conditions at the site should also be considered.

Bulk samplers are recommended only if it can be shown that the contamination by dry deposition of dust and gases e.g. ammonia is negligible, and during periods when the precipitation is mainly in the form of snow. Wet-only samplers are unsuitable for collection of snow, because of generally poor aerodynamic designs, and because heating of the funnel to melt the snow may cause serious evaporation and concentration of the sample. The response of the conductivity sensors to dry snow is also poor.

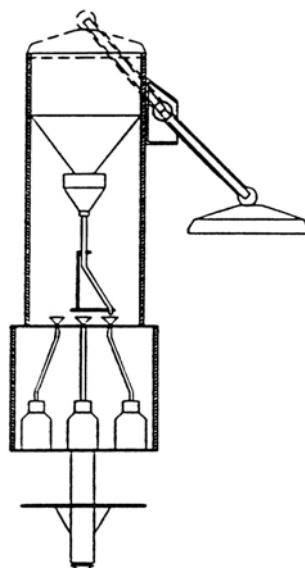

Figure 3.1.1: Precipitation collector type PR1410.

Table 3.1.1: Commercially available wet-only collectors.

Name	Manufacturers address	Comments
ERNI	Firma Eigenbrodt, Königsmor/ Kr. Harburg, D-21255 Germany. http://www.eigenbrodt.de	Rather bulky design. Old models have a relatively insensitive precipitation sensor, and funnel made from stainless steel. Replacement of these parts is possible.
MISU	Department of Meteorology, Stockholm University, S-106 91, Stockholm, Sweden. http://www.misu.su.se	Simple design, modest size and good collection efficiency.
ECN (PR1410)	Van Essen Instruments BV, PO Box 553, NL-2600 An Delft, The Netherlands. http://www.vanessen.com/	Good geometrical design. Can be used to collect up to 7 (daily) samples without attention.
APC 70	Hydrolog Limited 63 Constitution Street Edinburgh EH6 7AF, UK http://www.hydrolog.co.uk/	
WADOZ	Dipling, A. und Kroneis, W., Werkstätten für Messgeräte G.M.B.H., Iglaseegasse 30-32, A-1190 Wien, Austria. http://www.kroneis.co.at	

All materials that come in contact with the sample must be chemically inert. Polyethylene, tetrafluoroethylene and tetrafluoroethylene-fluorinated ethyl-propylene copolymer are generally recommended because of their excellent chemical properties. The mechanical properties of these materials must be taken into account in the construction of samplers, however. Polyethylene may become brittle when exposed to sunlight, and should be replaced after 1 year of use involving exposure to sunlight. Borosilicate glass should be properly acid-washed and rinsed in deionized water prior to use, but the use of glass is not generally recommended. Soft glass will contaminate the sample with alkali and alkaline earth cations. Metals and artificial materials with unknown chemical properties or

composition should be avoided. If such materials have to be used in joints or in other constructional details, boil a sample of the material in deionized water and analyze the water afterwards as a precipitation sample!

The construction principles for precipitation gauges are relatively simple. The sampler should not be too large or bulky, because this will obstruct the air flow around the sampler. On the other hand, the diameter of the collector must be large enough to provide samples large enough for chemical analysis. In practice, a diameter of 20 cm is sufficient. If a funnel is used, there should be a vertical section of at least 5 cm height.

For a general review of errors in the collection of precipitation in precipitation gauges, reference is made to Sevruck (1989). There are 4 sources of error if the sampler is equipped with a sensor-activated automatic lid:

- (1) aerodynamic error, when the gauge fails to catch the same amount of precipitation which falls on the surface,
- (2) evaporation errors, when part of the precipitation evaporates after the precipitation event, and before the amount is collected or measured, and
- (3) the wetting error, which occurs because not all of the precipitation is transferred to the measuring cylinder,
- (4) Failure of the lid to open in situations with light precipitation or snow.

The aerodynamic error is reduced by proper design of the collector, and by choosing the sampling site carefully. It cannot be entirely eliminated and may be very serious at windy sites, and particularly for snow. Use of a windshield (Nipher or Wyoming) may be necessary for sites where a large fraction of the precipitation is in the form of snow.

However, at many sites the collected amounts of precipitation will be a good measure of the precipitation amounts even if no particular measures have been taken. Consultation and co-operation with meteorological services running precipitation gauge networks is strongly recommended when selecting sites and precipitation collecting equipment.

The evaporation effect is reduced if an automatic closing lid is used, but the lid must form an airtight seal with the rim of the collector. For bulk collectors of the funnel and bottle type, diffusion through the funnel stem reduces the evaporation effect.

The wetting error is due to the liquid film on the inside of the collector. The equivalent volume of this liquid film is related to the internal surface of the collector, and may be determined experimentally, for example by weighing the collector in dry condition, spraying with water, "emptying", and weighing again.

It is not unusual to find a wetting error corresponding to 0.2 mm of precipitation. Winkler et al. (1989) have measured the wetting film on several commercially available precipitation collectors.

Evaporation changes are particularly serious, since this may result in a significant concentration of the sample. Electrical heating of the precipitation collector in order to melt precipitation in the form of snow is therefore not recommended. It is acceptable, however, to apply electrical heating when the lid is firmly closed.

In order to obtain a more accurate measure of the precipitation amount, WMO GAW has equipped their sites with a rain gauge in addition to the wet-only collector. This improves the measurements of deposition, and will, provided that the Steering Body agrees, be implemented also for EMEP sites as one step in a harmonization process.

When precipitation is in the form of snow, it is advisable to use a special snow collector, in the form of an open polyethylene cylinder of diameter 20 cm. The height of the cylinder should be at least twice the diameter to prevent "blow-out". The snow collector should be equipped with a tight-fitting polyethylene lid, which is put on when the collector and sample is brought indoors for the sample to melt.

Proper design, construction and maintenance of the sampling equipment is essential in order to avoid serious errors because of poor performance of the precipitation sensor and automatic lid system. The sensor should be designed with a response which will cause the lid to open when the precipitation intensity exceeds 0.05 mm/h.

Additional equipment at the sampling site will include:

- Spare parts for precipitation collectors,
- Distilled(deionized) water storage bottle,
- Polyethylene spray bottle,
- Filter paper or tissue paper for cleaning,
- Disposable plastic gloves,
- Acetone for cleaning,
- Measuring cylinders,
- Funnel,
- Balance, 0-500 g.,
- Storage bottles, transport containers.

3.1.5 Sampling procedure

Samples are collected on a daily basis, at the same time as used in the official precipitation measurement network. Usually this will be at 0800 local time. If daylight savings time (summer time) has been introduced, samples should be collected according to the "normal" time. The daily sample collection involves transfer of the sample to a sample storage and transport bottle, measuring the sample volume, and cleaning of the equipment which has been used. The exact procedure will vary according to the equipment used at the sites. A detailed, written standard operating procedure must be worked out for each site and should be readily available at the site, in the national language of the operator. As an example, the procedure could consist of the following steps:

1. Collect the equipment needed for change of samples. Label the storage and transport bottle with station code and name, and start and end of the sampling period.
2. If there is any chance for the operator to touch the inside of the collecting funnel, disposable polyethylene gloves should be put on.
3. Exchange the collection bottle in the precipitation sample collector and put on a screw-stopper. Check that the collection equipment functions correctly by putting a drop of water on the precipitation sensor. Examine the collector funnel for visible contamination such as insects, leaves or tree-needles, organic debris. If this is found, remove the contamination and rinse with distilled water. If a bulk collector is used, the collecting funnel should be rinsed with distilled water every day. After the distilled water has drained off, put on the new collection bottle.
4. Take the collection bottle indoors to the room assigned to function as the sampling laboratory.
5. Weigh the bottle, transfer a suitable aliquot (50-100ml) to the labelled storage and transport bottle. (Alternatively, measure the volume in a graduated cylinder. Use a large cylinder (0-250 ml) for large samples, and a small (0-25 ml) cylinder for small samples).
6. Put the storage and transport bottle in the refrigerator until it can be sent to the laboratory for chemical analysis.
7. Pour out the remainder of the sample, rinse with distilled water and place the collecting bottle upside down in a clean place to dry. Also rinse the graduated cylinders.
8. Take off and discard the disposable plastic gloves.
9. Fill in the field sample registration form, and take time to record usual and unusual events which may have influenced the sampling. Examples are given below (these should be elaborated for each site, because of the different conditions):
 - Visible contamination of the sample or the collection funnel (describe the contamination, see 3 above)
 - Agricultural tilling and sowing (in the surroundings or on adjacent fields).
 - Fertilizing
 - Liming
 - Manure spreading
 - Burning of stubble, or other fires in the area
 - Construction work
 - Unusual smell, (try to describe the smell)
 - Strong haze (visibility)
 - Pollen

- Visible deposition of dust
- Strong winds, e.g. in connection with thunderstorms.

3.1.6 Chemical analyses

Most of the major ions in precipitation samples may be determined by ion chromatography, which is the generally recommended method for anions such as chloride, nitrate and sulphate. Table 3.1.2 gives a list of alternative recommended methods, with reference to more detailed descriptions and procedures in Section 4. It is not recommended to filter samples.

Table 3.1.2: Recommended and alternative methods for chemical analysis of precipitation within EMEP.

METHODS		
Component or parameter	Recommended methods	Alternative
Conductivity	Conductivity cell and resistance bridge	
Hydrogen ion (H ⁺)	Potentiometry (glass electrode) pH<5.0	Titration
Ammonium ion (NH ₄ ⁺)	Ion chromatography	Spectrophotometry (indophenol blue colour reaction)
Sodium ion (Na ⁺)	Atomic absorption spectrophotometry (AAS)	Ion chromatography
Potassium ion (K ⁺)	AAS	Ion chromatography
Magnesium ion (Mg ²⁺)	AAS	Ion chromatography
Calcium (Ca ²⁺)	AAS	Ion chromatography
Sulphate ion (SO ₄ ²⁻)	Ion chromatography	
Nitrate ion (NO ₃ ⁻)	Ion chromatography	Reduction to nitrite and diazotation
Chloride ion (Cl ⁻)	Ion chromatography	Displacement of SCN ⁻ in Hg (SCN) ₄ ²⁻ , determination of coloured Fe(SCN) complex.
Bicarbonate ion (HCO ₃ ⁻)	Titration	
Formate ion (HCOO ⁻)	Ion chromatography	
Acetate ion (CH ₃ COO ⁻)	Ion chromatography	

The last three anions are not part of the ordinary EMEP measurement programme. They are included here, however, because they are found in precipitation samples in concentrations comparable to some of the other ions, and may be necessary to explain the ion balance and measured conductivities, particularly for samples with pH above 5. Note that most of the components can be determined by ion chromatography, which is strongly recommended for the anions sulphate, nitrate and chloride. However, ion chromatography holds no advantages over conventional methods when it comes to determination of ammonia and base cations.

3.1.7 Calculation and reporting of results

The amount of precipitation is to be calculated from the collected sample volume, simply by dividing by the area of the sampling orifice. No corrections are to be made for sampling errors, such as undercatch, evaporation or the part of the sample remaining in the collector because of the wetting effect. An assessment of these errors should be performed and be available.

Additionally, the amount of precipitation measured by rain gauge should be reported to the CCC.

Conductivity and pH is reported in $\mu\text{S}/\text{cm}$ and in pH units, respectively. All other parameters are reported as elemental concentrations in mg/litre. Note especially that nitrate, ammonium and sulphate concentrations are to be given as equivalent weight concentrations of nitrogen and sulphur. Table 3.1.3 gives reporting units and conversion factors.

Table 3.1.3: Units and conversion factors.

Ion	Reporting form	Mol /mg
Sulphate (SO_4^{2-})	mg S/litre	$31.19 \cdot 10^{-6}$
Nitrate (NO_3^-)	mg N/litre	$71.39 \cdot 10^{-6}$
Chloride	mg Cl/litre	$28.21 \cdot 10^{-6}$
Hydrogen (H^+)	(pH)	
Ammonium (NH_4^+)	mg N/litre	$71.39 \cdot 10^{-6}$
Sodium (Na^+)	mg Na/litre	$43.50 \cdot 10^{-6}$
Potassium (K^+)	mg K/litre	$25.57 \cdot 10^{-6}$
Magnesium (Mg_2^+)	mg Mg/litre	$41.13 \cdot 10^{-6}$
Calcium (Ca_2^+)	mg Ca/litre	$24.95 \cdot 10^{-6}$
Conductivity	$\mu\text{S}/\text{cm}$	

Before the results are sent to the CCC, they should be examined for internal consistency by the responsible laboratory. The procedure for this examination is given under Section 6, which also contains data flags and gives information on data reporting.

3.1.8 Quality assurance

Site operation

Standard operation procedure must be available at the site, together with necessary equipment, deionized water for cleaning and rinsing, replacement parts for precipitation collector. Operators should be trained and required to carry out all necessary operations under the surveillance of an experienced analytical chemist or person responsible for the quality control. Operators should also be instructed on how to fill in the field sample registration form with the remarks column (see above) and to use this column extensively for reporting of conditions at the site.

If bulk samplers are used the funnel and collecting vessel must be cleaned every day.

The site should be inspected at least once a year, and the operation of the site examined by the National Quality Assurance Manager.

Field blanks and control samples

In order to check on possible contamination on the site, field blank tests should be carried out at least once every month. For this purpose, 50–100 ml deionized water samples are to be poured into the sample collector at the time of collection a day without precipitation, and subjected to the same procedure as an ordinary precipitation sample.

The quality of the precipitation chemistry data is strongly linked with the performance of the chemical laboratory. Control samples should be prepared, and analysed regularly as ordinary precipitation samples, in order to keep an independent check on the chemical analyses performed. Standard rainwater samples are available from NIST and BCR, and it is advised to use such samples as an external reference solution analysed only 2–4 times during the year, and in-laboratory prepared control samples for daily control work. The control samples should approximate the expected mean concentration level in the precipitation samples, and may be prepared from the following compounds:

(NH₄)₂SO₄
Nitric acid
CaSO₄ · 2H₂O
MgSO₄ · 7H₂O
NaCl
KCl

Sample transportation

The transportation time should be as short as possible and the samples contained together with freezer packs in insulated boxes.

Chemical laboratory

It is expected that the chemical laboratory is accredited under one of the laboratory accreditation systems, or is performing close to these standards, e.g. ISO 17025.

The laboratory must keep check on its performance, with respect to detection limits, precision and repeatability, by repeated analyses of control solutions of known composition, analyses of synthetic rain samples prepared by other laboratories (preferably traceable to NIST or other certified standards), and reanalysis of at least 5% of all samples.

Quality control samples are to be included in the sample series each day, and if results are differ more from the expected than the targets for accuracy and precision, full reanalysis of the sample series must be carried out. Results of the analyses of control samples are to be reported to the CCC.

Data reporting and validation

The chemical analysis data should be used to check the data for consistency, by calculating the ion balance and by comparing measured and calculated electrical conductivity (Section 6).

Results from the analysed control samples should also be checked, in order to ascertain that the chemical laboratory's performance has been acceptable.

Results should also be compared with the site operator's notes, to see if untypical results are due to special activities or conditions at the site. If it is decided to reject or to correct data, the reason for the correction should be stated, and the data should be flagged. Examples of such permissible corrections may include contamination from nearby fields due to manuring or tilling, high concentrations of potassium and ammonium indicating contamination by bird droppings, a.o. Such samples should be excluded from the calculation of monthly, or yearly weighted mean concentrations.

Comparison of reported sample volumes with daily precipitation amounts from a standard meteorological rain gauge at the site is strongly advised, since this gives an independent control of the sample collection.

This assessment of the data should be carried out on a monthly basis, as soon as chemical analysis data are available.

3.1.9 Special problems in precipitation sampling and analysis

The above procedures relate to normal operations of a precipitation site, assuming that there are no particular problems with the collection of the samples. This is normally the case, at least for the main constituents, at most of the EMEP sites.

By collecting samples on a daily basis, and storing the collected samples refrigerated and in the dark, it is generally hoped to avoid biodegradation of the samples. As the precipitation is now gradually becoming less acid, there may be more reason to make sure that such bio-degradation does not take place. Bacterial growth will primarily reduce the concentration of ammonium ions and organic ions.

The acidity of a sample is usually determined by the concentrations of non-marine ("excess") sulphate and nitrate, less the concentration of base cations such as ammonium, calcium, potassium and magnesium. However, if the pH is higher than 5, dissociation of dissolved carbonic acid and organic acids such as formic and acetic acid may also contribute to the observed concentration of hydrogen ions, and the equilibrium concentration of ammonium ion is a function both of the pH and the ambient concentration of gaseous ammonia. For a discussion of the chemical equilibria involving ammonia and carbon dioxide, reference is made to Charlson and Rodhe (1982). Formic and acetic acid are thought to be formed mainly by oxidation of hydrocarbons via formaldehyde and acetaldehyde, and concentrations in precipitation samples are typically 2–20 micro-equivalents/litre (Keene and Galloway, 1988). Other organic acids may also be present, either as a

result of photochemical oxidation processes, or generally from decay of organic materials.

While the contamination of the sample by soil dust of local origin should be avoided, there is also evidence of large-scale atmospheric transport of fly ash, soil dust and desert dust. The input of base cations from such sources is large enough to be of importance in the assessment of critical loads in relation to soil acidification.

Installations of emission control devices in the latest decades have reduced the emissions of fly ash and other alkaline dust. Only total emissions in weight units are usually available, data on the chemical composition and size distributions are lacking.

Wind erosion may be a serious problem in agricultural areas, and the soil dust has sometimes been transported over quite considerable distances. Significant amounts of soil dust and alkaline material also becomes airborne in connection with agricultural tilling and harvesting operation. Burning of straw and stubble also releases alkaline material in addition to soot.

Desert dust from Sahara is frequently observed in the Mediterranean countries, occasionally also in Northern Europe. In addition to quartz and feldspar minerals, Sahara dust also contains calcite, which is readily soluble in precipitation samples.

Feldspar and clay minerals may be partly soluble in precipitation samples and contribute to the concentrations of base cations. Aluminium ions may also be present in the precipitation samples.

Determination of the main inorganic ions and pH also allow the calculation of the ionic balance of the samples, provided that the pH is less than 5. For samples with higher pH, determination of the concentrations of anions of weak acids, e.g. formate, acetate, and bicarbonate, may be necessary in order to determine the ion balance and to explain measured conductivities.

3.1.10 References

- Charlson, R.J. and Rodhe, H. (1982) Factors controlling the acidity of natural rainwater. *Nature*, 295, 683-685.
- Granat, L., Areskaug, H., Hovmand, M., Devenish, M., Schneider, B., Bieber, E., Marquardt, W., Reissell, A., Järvinen, O., Hanssen, J.E., and Sjöberg, K. (1992). Intercomparison of precipitation collectors for chemical analysis, HELCOM intercalibration -second stage. (Baltic Sea Environment Proceedings, 41). pp. 15-88.
- Keene, W.C. and Galloway, J.N. (1988) The biogeochemical cycling of formic and acetic acid through the troposphere, an overview of our current understanding. *Tellus*, 40B, 322-334.

Sevruk, B., ed. (1989) Precipitation measurement. Proceedings international workshop on precipitation measurements, St. Moritz, Switzerland, 3-7 December 1989. Geneva, World Meteorological Organization (WMO/TD 328) (Instruments and observing methods. Report 48).

Winkler, P., Jobst, S., and Harder, C.(1989) Meteorologische Prüfung und Beurteilung von Sammelgeräten für die nasse Deposition. München, Gesellschaft für Strahlen- und Umweltforschung (BTP-Bericht 1/89).

WMO (1971) Guide to meteorological instrument and observing practices. Geneva, World Meteorological Organization (WMO No. 8 TP 3).

3.2 Sampling of sulphur dioxide, sulphate, nitric acid, ammonia, nitrate and ammonium using the filter pack method

3.2.1 Introduction on the various sampling methods

The most commonly used method for sulphur dioxide measurements in EMEP today is the alkaline impregnated filter method. This is the recommended method, preferably in combination with ion chromatography, because it combines a small extraction volume and low measurement uncertainty with a large air volume, and therefore gives a good measurement accuracy even at low sulphur dioxide concentrations. At sites with annual average above $10 \mu\text{g S/m}^3$ the absorbing solution method can still be recommended and would give satisfactory results. Only few of the EMEP sites experience such concentrations at present. The UV-fluorescence monitor is the recommended procedure in EU; and many sites in EMEP also prefer using this due to its convenient sampling procedure and high time resolution. However, one disadvantage is the need of regular maintenance and skilled workers. The monitor needs frequent calibration, which is often difficult because most of the background stations are in remote areas. The sensitivity of the monitor is generally not as good as the manual method, giving uncertain results at concentrations below $1 \mu\text{g S/m}^3$. UV-fluorescence is therefore not recommended on background stations within the EMEP network.

Nitric acid in the gaseous state readily reacts with other atmospheric constituents to form nitrates in the form of atmospheric particles. If ammonium nitrate is formed, the reaction is reversible, and its presence requires a dissociation product of gaseous nitric acid and ammonia, which in turn depends on temperature and relative humidity (Stelson and Seinfeld, 1982). Sampling artifacts due to the volatile nature of ammonium nitrate, and possibly due to interaction with other atmospheric constituents make separation of these gases and particles by a simple aerosol filter unreliable. This can be achieved using denuders where one takes advantage of the different diffusion velocities of gas and aerosol particles in a sampling device, which is simply a tube coated on the inside by an absorbing reagent, usually sodium chloride or sodium carbonate. The same sampling principle may also be used for sampling of ammonia, using citric, oxalic, or phosphoric acid as the absorbent. Because the diffusion speed of ammonia in air is about twice that of nitric acid, a shorter diffusion tube will achieve >95% absorption. If the flow is laminar, minimal deposition of particles occur, and if the tube has proper dimensions in relation to the flow rate and the diffusion speed of gaseous nitric acid in air, nitric acid is efficiently deposited to the walls of the tube.

Two different denuder systems are available for sampling and determination of gaseous nitric acid and ammonia. The first procedure uses simple cylindrical tubes, as introduced by Ferm (1979). The second procedure uses so-called annular denuders, where the air is passed through the annular space between two concentric cylinders as described by Allegrini et al. (1987). This arrangement allows the airflow rate to be increased, and makes the subsequent chemical analyses somewhat less demanding. Two large field intercomparisons have been made for gaseous nitric acid, one in Italy (Allegrini et al., 1989), and one in the USA (Hering et al., 1988). Reference is made to these publications for further information on the performances of different sampling systems. Methods for

sampling and determination of ammonia have been compared in the field by Allegrini et al. (1992). The principles of using denuders are described in [section 3.4](#).

Denuders can be rather impractical and are relatively expensive, and as filter packs are mostly more reliable and less demanding in terms of sampling and sample preparation, this procedure is often chosen. However, since the filter pack technique is poorer when it comes to separate gas and particle phase, only the sum of nitric acid and nitrate and for the sum of ammonium and ammonia are obtained. Information on the partition between the gaseous and the particle formed may sometimes be inferred also from filter pack data. This may be the situation in areas where the concentration of gaseous ammonia is usually high, or where the concentrations of both nitric acid and ammonia gas concentrations are so low that the partial pressure product necessary for ammonium nitrate to be present is not reached. The separation of $\text{SO}_2/\text{SO}_4^{2-}$ is good in both techniques.

3.2.2 Principle of using filter pack

The first filter in the air stream is an aerosol filter for collecting the airborne particles containing sulphate, ammonium and nitrate. This is followed by an alkaline impregnated filter which will collect HNO_3 , SO_2 , HNO_2 , HCl , and other volatile acidic substances. Nitric acid and sulphur dioxide will react with potassium hydroxide on this impregnated filter to give potassium nitrate and potassium sulphite. The absorption of SO_2 is quantitative at a relative humidity above 30% at temperature down to -10°C (Lewin et al., 1977). Oxidizing species in air e.g. ozone are believed to convert most of the sulphite to sulphate during the sampling. It is also possible to include a third acid-impregnated filter for alkaline air component such as NH_3 . Ammonia is effectively retained on a filter impregnated with citric or oxalic acid. When a 3-filter pack is applied the acid impregnated filter should be the last in the air stream

Since the filter pack method cannot separate gaseous nitrogen compounds from aerosols only the sum can be given. In other words, the concentration of nitrates in air equals the sum of the nitrate found on the aerosol filter and nitrate found on the alkaline impregnated filter. The same for ammonium where the sum of ammonium concentration equals the sum of ammonium collected on the aerosol front filter and ammonia collected on the acid impregnated filter.

The filter material should not absorb SO_2 and should have acceptable collection efficiency for submicron particles. Cellulose filters are acceptable for this purpose, e.g. Whatman 40 filters, but membrane filters, e.g. teflon, are preferred.

3.2.3 Interference

During sampling, salts can react with aerosol particles containing sulphuric acid. The resulting volatile acid, e.g. nitric acid and hydrochloric acid will react with the potassium hydroxide on the impregnated filter to give potassium nitrate and potassium chloride. This will, however, not affect the measured concentration of sulphate in airborne particles or sulphur dioxide.

A bias may be introduced if the aerosol filter becomes wet during sampling since it is possible to have an absorption of sulphur dioxide on cellulose based filters.

This gives an overestimation of the sulphate concentrations in aerosols and a corresponding underestimation of the sulphur dioxide. Another source of error could be that the absorption of sulphur dioxide on the impregnated filter is not 100 per cent effective. Experiments with a second KOH-impregnated filter behind the first have, however, not given measurable amount of sulphur dioxide.

It may be possible to loose components before the analysis due to incomplete extraction from the filter.

3.2.4 Sampling equipment

Air intake and filter pack

A diagram showing the sampling principle is given in Figure 3.2.1. The air intake should have a cylindrical, vertical section 15 cm wide and at least 25 cm high. This air intake reduce the sampling efficiency for particles larger than 10 μm a.e.d., such as soil dust particles, large sea spray droplets, large pollen, and fog droplets. The filter pack is placed directly in the air intake, and it should have separate supports for the aerosol and the impregnated filters in order to avoid contamination from one filter to the next. An exploded view of a filter pack and its components is shown in Figure 3.2.2.

It is important to avoid leaks in the filter pack. The filter pack in Figure 3.2.2 should be tightened to the torque specified by the producer. Care should be taken to avoid materials in the filter pack which may be a source of contamination or absorb sulphur dioxide or other air components which are to be determined. Teflon, polyethylene, polypropylene, PVC, and polycarbonate are recommended materials. Ordinary rubber and nylon contains sulphur and should be avoided. Nylon will absorb nitric acid.

Since the absorption of sulphur dioxide is only quantitative at relative humidities above 30, sampling with a filter pack should take place outdoor, only sheltered from the ambient air by the air inlet. Additions of glycerol may improve the absorption efficiency of the impregnated filter at low humidities. Typical air volume, sampling rate, and flow velocity through the filters are respectively 20 m^3 , 15 l/min., and 15 cm/s.

Pump and gas meter

The filter pack should be connected to the sampling line with an airtight seal, using either a nut and gasket, or push-fitted tubing. The sampling line connects the air intake and filter pack to a pump and a gas meter in series. The pump should be a membrane pump of sufficient capacity to allow 15 l/min. against a pressure difference of 10-20 kPA (0.1 atm.), which is the typical pressure drop across two filters. It is essential that the pump is leakproof against outside air in order to allow reliable metering of the air volume at the outlet of the pump. A dry bellows-type gas meter may be used for recording of the air sample volume. This is a relative inexpensive instrument, which is readily available commercially. The accuracy of commercial gas meters is typically within $\pm 5\%$; calibration not less than once or twice a year is therefore mandatory. Better accuracy is obtainable with a wet gas meter. Both devices will record the air volume at the temperature and pressure conditions in the pump. If the pump and gas meter is kept at room

temperature, no corrections are usually required, and the air volume is then assumed to be the sample air volume at 20 °C. If deviations of more than ± 5 °C are expected, the temperature in the gas meter surroundings has to be recorded and the air volume corrected accordingly.

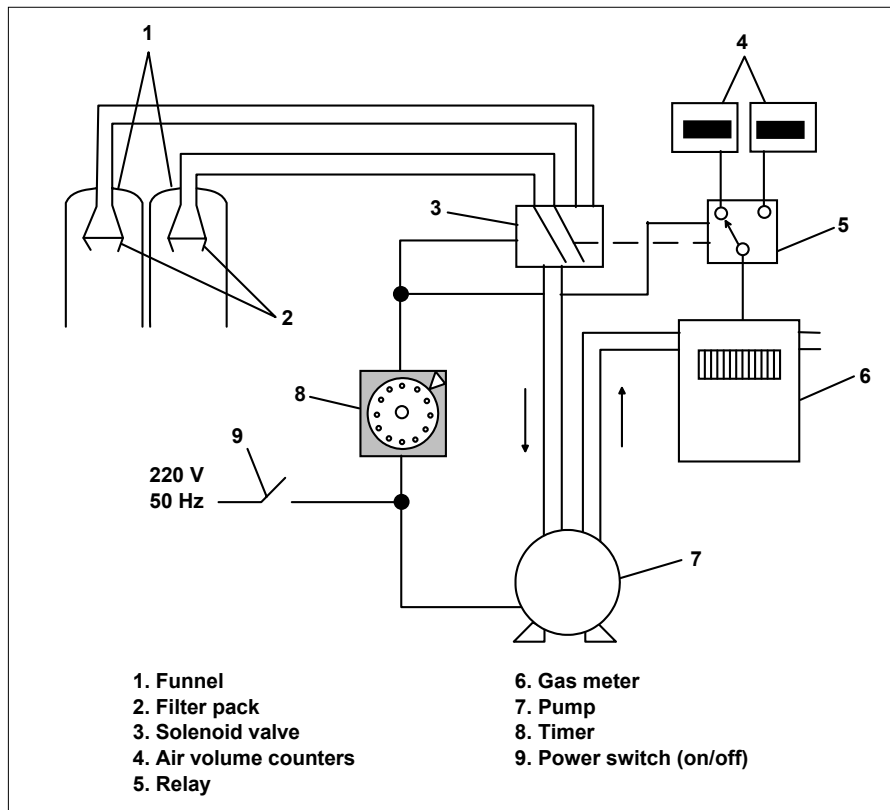

Figure 3.2.1: Sampling principle.

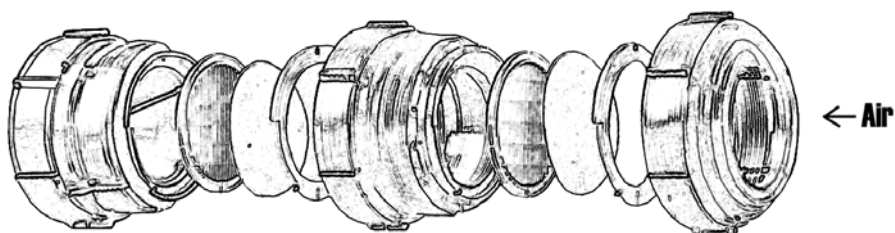

Figure 3.2.2: Filter pack with one aerosol filter and one impregnated filter for gases.

Sequential sampling

In order to facilitate operation of the sampler, it is possible to connect two or more air inlet and filter pack units to the same pump and gas metering device, letting timers control valves. This enables a collection of samples (exposed filter packs) and an inserting of new filter packs at a convenient time and without interruption of the sampling process. A schematic indication of how this may be carried out is indicated in Figure 3.2.1.

Mass flow controllers

It is possible to use mass flow controllers to control the sampling rate or to provide dynamic dilution of span gases for calibration purposes. In principle, these determine the heat capacity of the gas or air flowing through a capillary, and the temperature difference between two points is used to control the position of a needle valve. The disadvantage of this system is, besides the costs, the pressure differences 0.7–1.1 atm (10–16 psi) required over the needle valve to make the control function reliable. This makes it impractical to use this type of device to control the sampling rate in front of the pump unless the needle valve is replaced by another control valve requiring less pressure drop. The device can, however, preferably be used at the outlet of the pump to keep the sampling rate constant over the sampling period. Low-pressure mass flow controllers are available. The flowmeter must be properly calibrated, and a suitable recording instrument added, if a mass flowmeter is to be used as the only measure of the sample volume.

Commercial supply

A list containing only some of the suppliers of the various types of equipment is given below:

Prefilter for collection of aerosols:

Teflon filter by Gelman, Zefluor 2 µm.

Cellulose filters for impregnation with potassium hydroxide to be used for sampling of sulphur dioxide:

47 mm Whatman 40 (W40) cellulose filter

Whatman International Ltd., Maidstone, England

Filter packs for two or three filters, with clamp and wrench:

NILU Products, P.O. Box 100, NO-2027 Kjeller, Norway

Membrane pump:

GAST, Model DOA-P101-BN

MFG. Corp., Benton Harbor, Mich. USA

Gas meter:

FLONIDAN

Gallus 2000 G1.6

Islandsvej 29

DK-8700 Horsens, Denmark

Mass flow controller:

TYLAN GmbH

Kirchhoffstrasse 8

Eching, Germany

3.2.5 Site requirements

The sampler should be located at least 100 m from small-scale local sources, e.g. generators or houses heated with petroleum, coal, or wood.

Samplers for gas and aerosols should normally be located in a shelter with temperature regulation. The gas meter should be kept at $20\text{ }^{\circ}\text{C} \pm 5\text{ }^{\circ}\text{C}$.

Nitric acid is very reactive and is readily absorbed by vegetation and by other surfaces. It is therefore particularly important for this species that the site is well exposed and is not sheltered by tall vegetation close to the sampler. Ammonia is emitted mainly from decomposition of urine, and from the application of manure. To find representative sites for this component may therefore be very difficult, as a basic rule the measurements at the site should not be influenced by emissions, which take place within a radius of 2 km from the site. Within this radius there should be no stabling of domestic animals, no grazing by cattle or sheep on fertilized pastures, and no application of manure to agricultural fields.

Even more pertinent to ammonia than to other pollutants is the reporting of activities, which could affect the data, e.g. spreading of manure in adjacent agricultural areas. These data need to be flagged in the database.

3.2.6 *Sampling procedure*

Mounting and dismounting of filter packs

It is recommended that the filter pack is assembled and dismounted in the laboratory only. When assembling the filter pack, the parts should be tightened to the torque specified by the manufacturer to prevent leaks. Airtight protection covers need to be mounted in both ends of the filter pack. One random selected complete filter pack should be checked every second week for leaks. Each filter pack should be tagged with the site code in the laboratory before it is sent to the site.

Exposed filter packs should be opened in the laboratory and the filters put into plastic bags, which in advance, have been tagged with site code, start and stop of sampling, and filter type. The filters are now ready for a chemical treatment and the analysis. Normally there is a delay between this step and the time when actual chemical treatment and the analysis takes place. During this period the samples are to be kept in a refrigerator.

It is important to wear a pair of disposable plastic gloves when working with the filters and the filter packs.

Changing of filter packs at the site

At the site, and before the filter pack is mounted in the sampling line, the site operator has to write the start date on the filter pack, and likewise the end date of the sampling after exposure. Further details are to be written into the site journal and copied into site reporting forms, worked out for this purpose.

The sampling procedures may be slightly different from one air sampling system to another. When a two line sampling system is used with a timer, the exposure of a new filter pack starts at a preset time; an example of a recommended procedure at the site is as given below. The start and end of exposure should be between 0700 - 0900 local time:

- mark an unexposed filter pack with start date,
- read the pressure behind the exposed filter pack and record the reading in the journal,
- read the counter in the volume meter and record the volume in the journal,
- remove (unscrew) the air intake or funnel covering the exposed filter pack and remove (unscrew) the filter pack,
- dismount the covers from the new unexposed filter pack and mount them on the exposed filter pack,
- mount the new unexposed filter pack and the air intake,
- read the pressure behind the unexposed filter pack and record the reading in the journal,
- reset if necessary the counter or volume meter of the new filter pack,
- write the start of the exposure of the new filter pack in the journal,
- activate or programme the timer if necessary,
- put the exposed old filter pack in a plastic bag, seal it and put it in the refrigerator,
- copy the information from the journal into the site reporting form.

Transportation of samples from and to the laboratory

It is recommended to ship a one weeks supply of filter packs from the laboratory to the site, and vice versa, once every week. One extra filter pack, complete with filters, should be added as a field blank (i.e. one field blank every week). This filter pack should be handled in every way as the ones to be exposed, returned with the other filter packs from the batch, dismounted, and the filters given the same chemical treatment and analysis as the exposed filters.

Once every week the field operator fetch the seven exposed filters from the refrigerator as well as the one unexposed (field blank) filter pack, and put the filter packs in the transportation box together with the site reporting form covering the past week. Field reporting forms should always be put in a separate plastic bag in case of accidental leaks from precipitation samples, which may be contained in the same transportation box. Mail the transportation box to the laboratory.

Maintenance and calibration

The sampling equipment should be maintained in accordance with the manufacturer's specifications.

Accurate volume readings are important for the resulting measurement's accuracy, and the volume meters may need frequent calibrations. Calibrations should under no circumstances be less frequent than once or twice every year. The accuracy must be better than 5%.

Written instructions for maintenance and calibration need to be available at the site, and the operator should be familiar with the contents.

Use of filter blanks

It is recommended that 10 samples from each new batch of filters are analysed as laboratory filter blanks. The purpose of the filter blanks is to control the quality of

the filters rather than to estimate the laboratory detection limit. Normally, the blank values should be sufficiently low that their values can be ignored. If high blank values are found a problem has occurred which has to be identified and solved, e.g. by using filters or chemicals from another batch, and by inspection of the routines in the laboratory.

3.2.7 *Cleaning of filters*

Cellulose filters may contain small amounts of impurities and a cleaning of filters may therefore be necessary before use.

The cleaning process is demanding and it may therefore be omitted if the filter blanks from a new batch of filters are lower than the requirements given in Table 3.2.1, otherwise cleaning must be done. Following the cleaning, some filters are impregnated and the requirements for impregnation and extraction solutions are the same as those given in Table 3.2.1. See more details in 3.2.8 and 3.2.9.

Membrane filters should be tested at regular intervals in order to see if impurities occur. NILU make use of teflon filters; impurities have not been detected so far.

Table 3.2.1 Recommended requirements.

SO ₄ ²⁻	Better than	0.01 µg S/ml
Cl ⁻	“ “	0.01 µg Cl/ml
NO ₃ ⁻	“ “	0.01 µg N/ml
NH ₄ ⁺	“ “	0.01 µg N/ml

General procedure for cleaning

Figure 3.2.3 presents equipment, made of teflon, used for cleaning of filters. The procedure below is designed for cleaning of Whatman-40 cellulose filters (W40). The contents from 5-7 packages of W40 filters are put into a filter container with a perforated disk in each end, after which 20 litres of the cleaning solution is pumped through the filter container. After cleaning the filters should be rinsed with 20 litres deionized water.

After the rinsing, the clamps in both ends of the container should be tightened in order to force as much water as possible out from the filters. A filter pack loaded with aerosol filter, an alkaline impregnated filter, and an acid impregnated filter should next be connected to the intake side of the filter container, and the outlet side be connected to a vacuum pump in order to remove most of the remaining water in the cleaned filters.

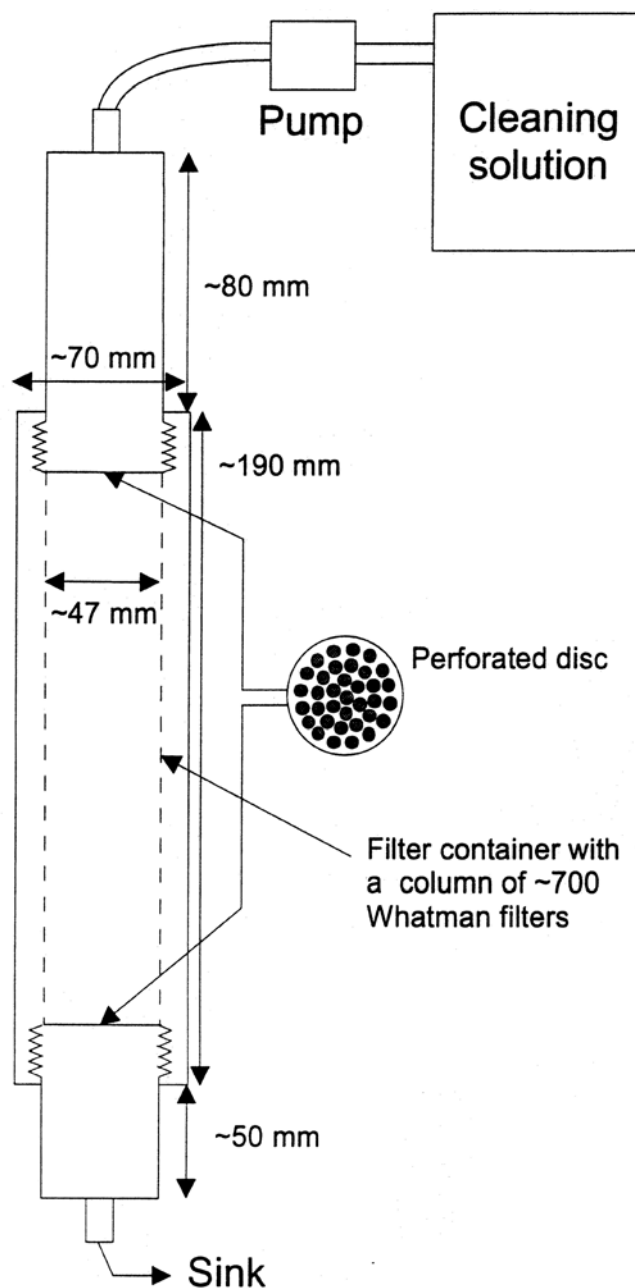

Figure 3.2.3: Equipment for cleaning of filters.

In the final step the container which still should be connected to the vacuum pump and filter pack, should be heated to, and kept overnight, at 100°C with the vacuum pump operating, in order to remove the last trace of water. After cooling the cleaned filters should be put in a plastic bag equipped with a zipper and the bag put in a desiccator. The filters inside the bag must not be bent, but must remain flat as in the original package. Before the filters are put into the bag, the bag should be labelled with the date of cleaning and cleaning reagent.

Tweezers and disposable gloves must always be used when handling filters.

After the cleaning 5 filters should be selected at random and the concentrations of cations and anions contained in the filters be determined as described in this manual. The concentrations found should be filled into the laboratory journal, and the label on the plastic bag signed and dated again if the concentrations are less than the detection limit of the analytical instrument. If one of the concentrations is higher than the detection limit, the cleaning must be repeated.

Cleaning of filters to be impregnated with KOH

The cleaning procedure is as described above. In order to avoid excessive blank values, the Whatman 40 filters used for acid gases may be washed with 20 litres 0.1 M K₂CO₃ (14 g K₂CO₃ pr. litre solution). After cleaning the filters should be rinsed with 20 litres water. If the SO₂, HNO₃ or NH₃ concentrations are high in the laboratory, the filters should be dried in a dry box, which is supplied with clean air.

Cleaning of filters to be impregnated with citric or oxalic acid

The cleaning procedure is as described above. The filters should be cleaned with 20 litres 0.1 M citric acid (25 g citric acid dihydrate pr. litre solution) if citric acid will be used for impregnation, or with 20 litres 0.1 M oxalic acid (13 g oxalic acid dihydrate pr. litre solution). After cleaning the filters should be rinsed with 20 litres of water.

3.2.8 Impregnation of filters

General procedure for impregnation solutions

A solution to be used for impregnation should be prepared the same day the impregnation of a new series of filters will take place. Before impregnation, the purity of the solution must be checked by adding 300 µl of the impregnation solution to 10 ml of the extraction solution, and the sample analysed. The following requirements to the impregnation solution should be met, or the concentrations should be lower than the instrument detection limit, table 3.2.1.

The recommended chemicals are given in Table 3.2.2.

Table 3.2.2: Specifications for chemicals used for impregnation.

Reagent	Quality	Formula
Oxalic acid	Merck p.a. 495 or corresponding	Oxalic acid dihydrate
Citric acid	Merck p.a. 244 or corresponding	Citric acid monohydrate
Potassium hydroxide	Merck p.a. 5033	KOH

The concentrations found should be filled into the laboratory journal.

Particularly for ammonia the chance for contamination is severe, since the ammonia concentrations in laboratories may reach 1-5 µg N/m³. The control of the impregnation solution is therefore important. The chemicals used for impregnation should be stored separated from the other laboratory chemicals. In

particular, the container with citric or oxalic acid should be stored together with the impregnated filters in a desiccator.

Procedure for impregnation of filters

The following procedure may be used. The filters are placed on plastic stoppers after which the impregnation solution is dripped on the filter (Table 3.2.3). The filters may be dried in air, usually is half an hour sufficient. When the filters are dried they must be placed in plastic bags and the zippers closed. The bags should be labelled with type of filters and date.

Disposable gloves and tweezers must be used when handling the filters.

Table 3.2.3: Impregnation of filters and recommended requirements to purity after impregnation.

Impregnation solution	Preparation	Volume	Purity requirement:
Alkaline filter: 1.0 M KOH/10% glycerol in methanol	5.6 g KOH, 10 ml glycerol, methanol to 100 ml volume	300 µl	Cl ⁻ < 0.01 mg Cl/l NO ₃ ⁻ <0.01 mg N/l SO ₄ ²⁻ <0.01 mg S/l
Acid filter: 0.33 M oxalic acid	3.0 g oxalic acid, methanol to 100 ml volume	300 µl	NH ₄ ⁺ <0.01 mg N/l
or 0.1 M citric acid	2.1 g citric acid, methanol to 100 ml volume	300 µl	NH ₄ ⁺ <0.01 mg N/l

Control of the impregnated filters

5 filters should be selected at random after drying and analysed as described in this manual. The requirements to the concentrations are identical to the ones in Table 3.2.3. If the requirements are not met, all filters from the impregnation batch should be thrown and a new batch made. If the requirements are met the bags should be signed and dated.

The concentrations found should be filled into the laboratory journal.

Storage of impregnated filters

The bags filled with impregnated filters should be stored in desiccators; alkaline impregnated filters in one desiccator and acid impregnated ones in a different one. The desiccator for KOH impregnated filter should have KOH at the bottom, and the one for acid impregnated filter should have citric acid at the bottom.

Impregnated filters should not be stored more than 3 months before use.

Summary of quality assurance steps

- Disposable gloves and tweezers should be used when handling the filters.
- Cellulose filters should be cleaned if necessary before use.

- After each cleaning and drying process 5 filters should be analysed for major ions and all concentrations meet strict requirements.
- An impregnation solution should be used the day it is prepared.
- An impregnation solution should be analysed for major ions before used, and all concentrations meet strict requirements.
- Impregnated filters should be kept inside dated and signed plastic bags with zippers, and the bags kept in a desiccator together with the impregnation reagents.
- The desiccator should be filled with the (solid) impregnation reagent at the bottom. Oxalic acid may be replaced by citric acid.
- After impregnation and drying, 5 filters should be analysed for major ions and all concentrations meet strict requirements.
- Impregnated filters should not be stored more than 3 months.
- All quality assurance steps and results should be recorded in the laboratory journal.

3.2.9 Extraction from filters

This section contains procedures for extraction of major ions collected on impregnated filters as well as on aerosol prefilters. The procedures given are the recommended ones provided that the procedures for filter impregnation in Section 3.2.8 have been followed.

Preparation of extraction solutions

When the impregnation has followed the procedures in Section 3.2.8, the composition and amount of extraction solutions to be used are given in Table 3.2.4. The exposed impregnated filters are put into a test tube or other suitable vessel with additions of extraction solution. Hydrogen peroxide solution is used for the alkaline filter in order to oxidize any remaining sulphite to sulphate. The quality requirements to the reagents are given in Table 3.2.1.

Table 3.2.4: Preparation and amount of extraction solutions for impregnated filters.

Filter/solution	Preparation of extraction solution	Amount of extraction solution
Alkaline filter 0.3% H ₂ O ₂	10 ml 30% H ₂ O ₂ to 1000 ml deionized water	10.0 ml
Acid filter 0.01 M HNO ₃	10 ml 1.0 M HNO ₃ to 1000 ml deionized water	10.0 ml

After preparation, and every day before use, 10.0 ml of the extraction solution should be analysed for major ions and the concentrations meet the requirements in Table 3.2.1 or be less than the instrument detection limit.

The volume of the extraction solution used must be measured accurately and a 10 ml precision dispenser should therefore be used. It is known that the accuracy will change with time, and the accuracy needs to be checked at regular intervals by weighing 10.0 ml of the extraction solution.

The results of the control analysis of the extraction solution and the control of the dispenser volume should all be recorded in the laboratory journal.

Table 3.2.5: Specifications for chemicals used during extraction.

Reagent	Quality	Formula
Hydrogen peroxide	Merck p.a. perhydrol or corresponding	H ₂ O ₂
Nitric acid	Merck p.a. or corresponding	HNO ₃
Water	MilliQ-water or corresponding	

Extraction procedure for impregnated filter

The impregnated cellulose filters requires careful treatment not to loosen fibres, which will cause problems during the analysis. The filters should be extracted the day they are removed from the filter pack. They may be put directly into tubes made of polystyrene fit for an autosampler. The stopper should be put on the tube at once and even before adding the extraction solution unless this is done at the same time. Disposable gloves and tweezers should be used when handling the filters. The tubes should be kept in the refrigerator until analysis.

The filters are extracted with 10.0 ml of the extraction solution. The rack with the stopped tubes should be turned upside down by hand at least ten times to ensure a good extraction and a homogeneous solution. It is necessary to allow any fibres in the solution to settle a few hours before analysis. If the analysis will be performed the next day or later, the tubes should be stored in a refrigerator.

The solution containing the acid filters may develop gases during and after the extraction. It is advisable to keep the tubes with the solutions in the laboratory a few hours, then to open the tubes to let any gas out before the tubes are moved to the refrigerator.

Extraction from aerosol filter

The aerosol teflon filters should be given an ultrasonic treatment before analysis in order to obtain a complete extraction. The filters are put into tubes and 10.0 ml of deionized water added. The rack with the tubes should be kept in the ultrasonic bath for 30 minutes.

Pre-treatment of acid extract before analysis

The extracts from the acid-impregnated filters may be too acidic to allow a direct analysis with the indophenol method. It is necessary to raise pH ~12 with a buffer, or with potassium hydroxide, for analysis. When preparing control samples (spiked samples) for this analysis, the same extract, and additions of buffers or potassium hydroxide should be applied.

Pre-treatment of KOH extracts before analysis

For some analytical methods e.g. the spectrophotometric Griess method (section 4.3 and 4.11.3), the extract from an alkaline impregnated filter has a too high pH to permit a direct analysis. In this case, 10 mg moist cation resin is added to the solution in the tube and the contents mixed well. After half an hour check the pH in the solution by putting one drop on a pH-paper. The solution should be neutral or slightly acid.

The remaining ion exchange material is completely removed during analysis when the sample is passed through the column of ion exchange resin.

Summary of quality assurance steps

- Disposable gloves and tweezers should be used when handling the filters.
- After preparation and every day before use, 10.0 ml of the extraction solution should be analysed for major ions and all concentrations meet strict requirements.
- The extraction solution volume given by the 10.0 ml dispenser should be controlled at regular intervals by weighting the liquid.
- The filters should be extracted the same day as removed from the filter pack.
- The solutions should be kept in a refrigerator after extraction unless the analysis can be performed the same day.

3.2.10 Calculation of results

The concentrations of the sum of nitric acid and nitrate in aerosols in $\mu\text{g N/m}^3$ is obtained by adding the nitrate from the aerosol filter extract and the alkaline filter extract. If

a_1 expresses the concentration of nitrate from the aerosol filter in mg N/litre,

v_1 is the aerosol filter extraction volume in ml

a_2 expresses the concentration of nitrate from the impregnated filter in mg N/litre,

v_2 is the impregnated filter extraction volume in ml,

v_L is the air volume through the sampler, in cubic meter at approximately 20°C and corrected for height from elevated sites,

then the total nitrate concentration in $\mu\text{g N/m}^3$ is given by the following expression:

$$C = \frac{a_1 \cdot v_1 + a_2 \cdot v_2}{v_L}$$

The concentrations of the sum of ammonia and ammonium in aerosols in $\mu\text{g N/m}^3$ is obtained by adding the ammonium from the aerosol filter extract and from the acid filter extract. It can be calculated similar as for total nitrate.

The concentrations of sulphur dioxide in the air sample expressed in $\mu\text{g S/m}^3$ is given by:

$$C = \frac{a \cdot v_1}{v_2}$$

a is concentration of sulphur in mg/l read from the calibration curve,

v_1 is the liquid volume containing the sulphate ions, e.g. 10 ml if a 10 ml extraction solution were used,

v_2 is the air volume from the sampler, in cubic meter at approximately 20 °C, and corrected for height from elevated sites.

3.2.11 Quality assurance

Handling of filters and filter packs in the laboratory

- Always wear disposable plastic gloves and use a pair of tweezers when handling filters,
- keep the impregnated filters in air-tight plastic bags,
- air-tight covers must be mounted in both ends of the filter pack once the filter pack has been assembled,
- filter packs should be tightened to the specified torque to avoid leaks after assembly,
- one filter pack selected at random should be checked for leaks every second week,
- each filter pack should be tagged with site code in the laboratory,
- exposed filter packs should only be opened in the laboratory, and the filters kept in air-tight plastic bags in a refrigerator before further chemical treatment.

Handling of filters and filter packs in field

- Filters should only be handled in the laboratory,
- each filter pack should be tagged with start time (day-hour-minute) by the field operator before being mounted in the sampling line, and with stop time when dismantled after exposure,
- covers removed from the new filter pack should be mounted on the exposed one when the samples are changed,
- filter packs should be kept in a plastic bag in the refrigerator at the site.

Maintenance and calibration of field equipment

- Maintenance performed in accordance with written instructions for the field instruments in question,
- calibrations of measuring devices at least once every year.

Field blanks

- As a field blank, one complete filter pack should follow the other filter packs every week,
- the field blanks should be analysed as the normally exposed samples to control the performance of the measurement system, and to give data for the assessment of the measurement detection limit.

Chemical analysis

- Calibration should be carried out in the beginning, and end of a series of samples, not to exceed 50, and at the end of the day at the latest. The average of the calibrations before and after a sample series should be applied,
- 5% of the samples should be split and the results used to quantify the analytical precision,
- 5% of the samples should have known, and realistic, concentrations and should be run between the normal samples to control the performance of the analytical system,
- 5% of the samples should be blank samples used to quantify the analytical detection limit.

Transportation

- Transportation time should be kept as short as possible.
- All quality assurance steps and results should be recorded in the laboratory journal.

3.2.12 References

- Allegrini, I., de Santis, F., di Paolo, V., Febo, A., Perrino, C. and Pozzanzini, M. (1987) Annular denuder method for sampling reactive gases and aerosols in the atmosphere. *Sci. Tot. Environ.*, 67, 1-16.
- Allegrini, I., Febo, A., Perrino, C., eds. (1989) Field intercomparison exercise on nitric acid and nitrate measurements. Rome, September 18-24, 1988. Brussels, CEC (Air Pollution Research Report, 22).
- Allegrini, I., Febo, A., Perrino, C., eds. (1992) Field intercomparison exercise on ammonium measurement. Rome, April 29-May 4, 1990. Brussels, CEC (Air Pollution Research Report, 37).
- Ferm, M. (1979) Method for determination of atmospheric ammonia. *Atmos. Environ.*, 13, 1385-1393.
- Hering, S.V. et al. (1988) The nitric acid shootout: field comparison of measurement methods. *Atmos. Environ.* 17, 2605-2610.
- Johnson, D.A. and Atkins, D.H.F. (1975) An airborne system for the sampling and analysis of sulphur dioxide and atmospheric aerosols. *Atmos. Environ.*, 9, 825-829.
- Lewin, E. and Zachau-Christiansen, B. (1977) Efficiency of 0.5 N KOH impregnated filters for SO₂-collection. *Atmos. Environ.*, 11, 861-862.
- Nodop, K. and Hanssen, J.E. (1986) Field intercomparison of measuring methods for sulphur dioxide and particulate sulphate in ambient Air. Lillestrøm, Norwegian Institute of Air Research (EMEP/CCC Report 2/86).
- Semb, A., Andreasson, K., Hanssen, J.E., Lövblad, G. and Tykesson, A. (1991) Vavihill, Field intercomparison of samplers for sulphur dioxide and sulphate in

air. Lillestrøm, Norwegian Institute of Air Research (EMEP/CCC Report 4/91).

Sirois, A. and Vet, R.J. (1994) Estimation of the precision of precipitation chemistry measurements in the Canadian air and precipitation monitoring network (CAPMON). In: *EMEP Workshop on the Accuracy of Measurements. Passau, 1993*. Edited by T. Berg and J. Schaug. Kjeller, Norwegian Institute for Air Research (EMEP/CCC Report 2/94). pp. 67-85.

Stelson, A.W. and Seinfeld, J.H. (1982) Relative humidity and temperature dependence of the ammonium nitrate dissociation constant. *Atmos. Environ.*, *16*, 993-1000.

Vet, R.J. (1988) The Precision and comparability of precipitation chemistry measurements in the Canadian air and precipitation monitoring network (CAPMON). In: *Expert Meeting on sampling, chemical analysis and quality assurance, Arona, Italy, October 1988*. Edited by K. Nodop and W. Leyendecker. Lillestrøm, Norwegian Institute for Air Research (EMEP/CCC-Report 4/88). pp. 177-192.

Vet, R. and McNaughton, D. (1994) The precision, comparability and uncertainty of air and precipitation chemistry measurements made during the Canadian-United States eulerian model evaluation field study (EMEFS). In: *EMEP Workshop on the accuracy of measurements. Passau, 1993*. Edited by T. Berg and J. Schaug. Kjeller, Norwegian Institute for Air Research (EMEP/CCC Report 2/94). pp. 115-134.

3.3 Sampling of nitrogen dioxide

A manual method based on absorption of nitrogen dioxide on a sodium iodide impregnated glass-sinter has been developed by Ferm and Sjödin (1993). Due to the reasons mentioned below, only the sodium iodide method has been included in this manual.

Several methods, both manual and continuous have been used for the measurement of nitrogen dioxide in ambient air. In urban air, the chemiluminescence method have replaced the manual absorption solution methods, and is introduced as an ISO standard (ISO, 1985a). The chemiluminescence method for NO₂ is based on reduction to NO by a heated catalytic converter and calculation of the concentration as the difference between (NO+NO₂) and NO (the signal without converter). For clean air sites commercial monitors are usually not sensitive enough, and since other reducible nitrogen compounds (e.g. HNO₃ and PAN) may exist in the same concentration level as NO₂, the method is not specific. However monitors with selective photolytic converters may be used if the sensitivity is adequate.

Also the liquid phase NO₂-luminol chemiluminescence reaction has been used in a commercial monitor for nitrogen dioxide at low levels (Schiff et al., 1986). This monitor has been shown to give almost interference-free values for NO₂ (e.g. Gehrig and Baumann, 1993). However a small interference from ozone has been observed by Kelly et al. (1990) and Hesterberg and Neftel (1993) found non-linearities under 1 ppb in addition to other systematically errors due to pressure variations in the inlet system and temperature changes in the reaction chamber. Since this monitor work with a liquid phase reaction, it needs more regular service than the ordinary chemiluminescence instruments.

The manual absorbing solution method based on direct Griess reaction during sampling (Saltzman method) has also been appointed an ISO standard (ISO, 1985b). This method is sensitive and more selective than the chemiluminescence method, but the colour to be measured spectrophotometrically is developed during sampling, and the measurement have to be performed immediately after sampling due to instability. This makes the method unsuitable if the exposed absorbing solution has to be transported to a chemical laboratory far from the sampling site, particular if temperature and light exposure cannot be controlled. Field inter comparison studies has shown that the Saltzman method is not suitable at concentration levels below 1 µg N/ m³ (EMEP, 1999).

Other absorbing solutions have been used in which nitrogen dioxide is absorbed and transformed to nitrite (EMEP, 1977). These methods are usually not sensitive enough in background areas, and also have the problem of instability of the exposed absorption solution during transport when the temperature and sunlight cannot be controlled. There has also been considerable uncertainty about the absorption efficiency of the absorbing solutions, and to which extent this varies with concentration. The use of experimentally determined absorption efficiencies has shown to be inadequate (Fährnich et al., 1993).

3.3.1 Determination of nitrogen dioxide using the iodide absorption method

3.3.1.1 Introduction

This method (Ferm and Sjödin, 1993) is based on the same principle as the method developed by Pavlenko and Volberg (1979, 1991). This method is recommended at EMEP stations with low concentrations of NO₂ and where the analysis has to be performed in a laboratory far from the sampling site.

3.3.1.2 Principle

Ambient air with a flow rate of about 0.5 l/min is drawn through an air intake (inverted funnel) and a glass filter impregnated with sodium iodide (NaI) and sodium hydroxide (NaOH). Nitrogen dioxide is absorbed in the filter and the iodide reduces NO₂ to nitrite (NO₂⁻). The hydroxide is converted to carbonate during sampling due to uptake of carbon dioxide. The nitrite formed on the glass filter is extracted with deionized water. After extraction the nitrite concentration can be determined photometrically by the Griess method described in Section 4.11.

This method can be used for measurement of nitrogen dioxide on a 24 h basis in ambient air within the range 0.1-10 µg NO₂-N/m³, assuming an air sample of 0.7 m³ and an extraction volume of 4 ml. Exposed samples are stable for several weeks and can be transferred to a laboratory for chemical analysis.

3.3.1.3 Sampling efficiency and interference

The sampling efficiency at a flowrate of 0.5 l/min and a relative humidity of 15% is higher than 98%. With a relative humidity higher than 60%, the sampling efficiency is higher than 98% even at a flowrate of 4 l/min. (Ferm pers. comm.).

Interference studies showed negligible formation of nitrate on the NaI/NaCO₃-substrate. Nitric oxide formation was also never observed behind the filter and no oxidation of nitrite by ozone is found. The absorption of PAN (peroxyacetyl nitrate) and the subsequent formation of nitrite on the alkaline NaI filter have been demonstrated with about 20% absorption (Ferm and Sjödin, 1993). This cause a positive interference which can be severe if the PAN-concentration is higher than the NO₂-concentration. This may happen in very remote areas, but not at most of the EMEP-sites.

3.3.1.4 Sampling equipment

Figure 3.3.1 shows the components of a suggested sampling system. The Figure shows an automated system, a simpler set-up with manual exchange of samples may also be used. The main components are:

Air inlet

An inverted funnel made of PTFE teflon, polypropylene, borosilicate or polyethylene should be used in order to prevent entrance of precipitation at the sampling point.

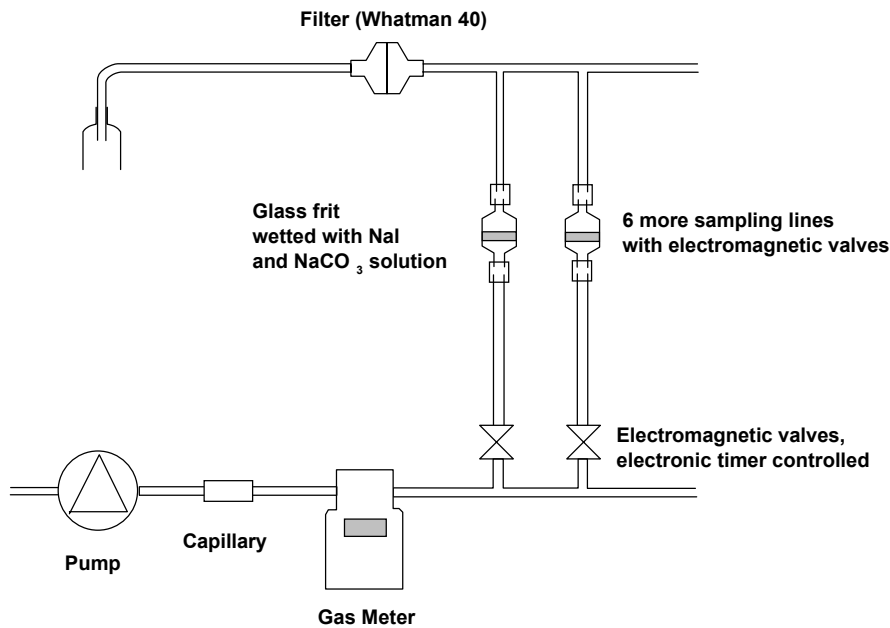

Figure 3.3.1: Sampling system for nitrogen dioxide.

Tubing

The sampling tube connection between the air inlet and the absorption system should be as short as possible, and made of PTFE teflon, polypropylene, borosilicate glass or polyethylene.

Filterholder with prefilter

A filterholder with a filter should be used in front of the absorption system in order to remove particulate matter. The filter must be inert to NO₂. A teflon membrane filter with a pore size 1–2 µm or a Whatman 40 cellulose filter or equivalent may be used. The filterholder and the connections to the sampling line must be airtight. The prefilter can be used for one week.

Absorption system

A 4 mm thick sintered glass filter 25 mm i.d. with a porosity of 40–60 µm enclosed in a glass bulb as shown in Figure 3.3.2 is used as a substrate for the impregnation. The glass bulbs should be connected to the sampling line using short pieces of silicon tubing. During transport the silicon tubing must be closed by pieces of glass or plastic rods.

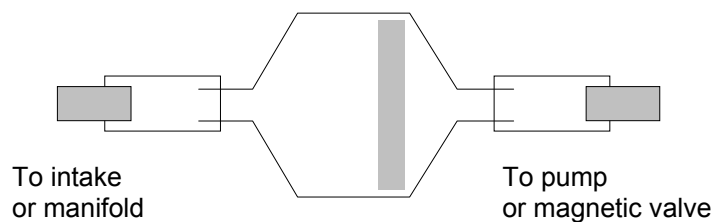

Figure 3.3.2: Sintered glass filter in a glass bulb.

Flow control device

In order to maintain a constant flow through the absorption system, a restrictor (glass capillary or hypodermic needle) or an electronic flow controller should be used.

Pump and gas meter

A membrane pump is recommended. If the pump is placed in front of the gas meter it must be leakproof. A calibrated dry or wet gas meter is recommended for recording the sampled air volume. Accurate air volume readings are most important for the accuracy of the measurement. Calibration of the gasmeter should be performed at least once a year. If the gas meter is placed in front of the pump, it must be assured that the pressure drop behind the absorption system is negligible.

3.3.1.5 Commercial supply***Pump:***

GAST, Model DOA-P101-BN
MEG. Corp., Benton Harbor, Mich, USA.

Gas meter:

FLONIDAN
Gallus 2000 G1.6
Islandsvej 29
DK-8700 Horsens, Denmark

Sinter glass filter in bulb:

Porosity 40-60 μm
Werner Glas & Instrument AB
Västra Rydsvägen 118
S-196 31 Kungsängen, Sweden
Tel.: +46 8 851 700 70, fax: +46 8 581 700 71

3.3.1.6 Site requirements

The site requirements for nitrogen dioxide are as for sulphur dioxide with respect to regional location and point sources. Particular attention should be paid to the possibility of contamination from motor vehicles, tractors, and other machinery with combustion engines. As nitrogen dioxide is taken up by vegetation, the air intake should not be sheltered by vegetation, but be freely exposed. The air intake should be 2–5 m above the ground. The sampling site should be at least 100 m away from any road open to public traffic, but the minimum distance to roads depends also on the traffic volume. This has been discussed in Section 2. The pump and sampling equipment should be placed in a room where the temperature is controlled at $20\text{ }^{\circ}\text{C} \pm 5\text{ }^{\circ}\text{C}$.

3.3.1.7 Preparation of the absorption system***Impregnation solution***

The impregnation solution consist of 9 g NaI and 1 g NaOH in 90 g methanol or ethanol (7.9 g NaI and 0.88 g NaOH in 100 ml methanol or ethanol). The solution should be made fresh for every new batch of filters to be prepared, due to possible uptake of nitrogen dioxide from laboratory air.

Cleaning of exposed samplers

Used samplers must be carefully cleaned before use. They may be left overnight soaked in deionized water to release old marking labels etc. After that the samplers are then cleaned by flushing deionized water into the back end of the tube (in the opposite direction of the sampling flow). At 0.5 - 1 litre of deionized water should be flushed through each tube to ensure a proper cleaning. After cleaning the samplers should be dried in a laboratory oven at 100 - 105°C.

Preparation of the sinters

500µl impregnation solution is added to carefully cleaned glass sinters. The sinters should be dried with a flow of NO₂-free air. For cleaning the drying air, a NaI impregnated filter should be used. The glass bulbs should be closed as soon as possible after the drying. Well-protected impregnated sinters can be stored for several weeks before, as well as after sampling, preferably in a cool place.

3.3.1.8 Sampling procedure

Assemble the sampling equipment at the site as shown in Figure 3.3.1, and make sure that the glass bulbs are coded with site name and date. Control that the equipment is leak free. Check the initial flowrate with the gasmeter. It should be about 0.5 l/min. Record the gasmeter reading at the start and again at the stop. For a 24-hour sample the total air volume should be about 0.72 m³. If a sequential sampler for one week is used, it is possible to record the total volume for seven samples and then divide by seven, provided the flow rate is kept constant. When using a sequential sampler it is important to check that the right glass bulb is actually exposed.

After sampling the glass bulbs must be sealed and sent to the laboratory for chemical analysis.

3.3.1.9 Preparation of samples and chemical analysis

Preparation of samples

Open the front end of the glass bulb and add carefully 4.0 ml of a 0.001 M (133 µl = 149 mg triethanolamine to 1 litre water) solution of triethanolamine in deionized water. (The triethanolamine is added to reduce the iodine formed in the reaction with nitrogen dioxide to iodide). The open end should be closed again and the bulb shaken for about 15 min. The lower end should then be opened and placed in a vial or test tube. When the upper end is opened the leaching solution flows through the glass sinter and into the test tube. Some of the solution may be removed by blowing air into the open end of the bulb. About 0.5 ml of the leachate will however remain in the glass filter using this procedure, and need to be thoroughly washed out when preparing the filter for new sampling. The NO₂⁻-concentration can be determined as described in Section 4.11 or by an automatic version of the method either in the flow-injection (FIA) or continuous flow mode.

Blanks

All steps in the described procedure, which could contaminate the samples, should be controlled regularly and properly documented.

Before using the impregnation solution, it should be controlled for the content of NO_2^- . In order to have the same concentration of the iodide reagent in this test sample as in the normal samples, 0.5 ml of impregnation solution is mixed with 4 ml deionized water before analysis. The analysis is performed as described in Section 4.11. The impregnation solution blank value should be less than 0.005 $\mu\text{g N/ml}$.

When a new batch of impregnated filters have been produced, 5% of the filters should be leached as the exposed samples. The leaching solution should be analysed in the usual way for NO_2^- . The amount of NO_2^- found should be less than 0.02 $\mu\text{g N/filter}$.

In every batch of impregnated filters sent to the sampling site, filters which shall remain unexposed (field blanks) must be included. For daily sampling, one field blank per station per week is needed.

3.3.1.10 Calculation of the air concentration

The concentration C of nitrogen dioxide in the air sample expressed as $\mu\text{g N/m}^3$ is given by:

$$C = \frac{a \cdot v_1}{v_2}$$

where a is the concentration of NO_2^- in $\mu\text{g N/ml}$ in the leachate,
 v_1 is the volume of the leaching solution, normally 4 ml,
 v_2 is the volume of the sampled air in cubic meter.

3.3.1.11 References

Aas, W, Hjellbrekke, A.-G., Semb, A. and Schaug, J. (1999) Data quality 1997, quality assurance, and field comparisons. Lillestrøm. Chemical Co-ordinating Centre, Norwegian Institute for Air Research (EMEP/CCC 6/99).

European Monitoring and Evaluation Programme (1977) Manual for sampling and chemical analysis. Lillestrøm, Chemical Co-ordinating Centre, Norwegian Institute for Air Research (EMEP/CHEM 3/77).

Fährnich, B., Hanssen, J.E. and Nodop, K. (1993) Comparison of measuring methods for nitrogen dioxide in ambient air. Lillestrøm, Chemical Co-ordinating Centre, Norwegian Institute for Air Research (EMEP/CCC-Report 3/93).

Ferm, M. and Sjödin, Å. (1993) Proposal of an impregnated filter technique for monitoring of NO_2 at EMEP stations. In: *EMEP Workshop on measurements of nitrogen-containing compounds. Les Diablerets, Switzerland, July 1992*. Lillestrøm, Chemical Co-ordinating Centre, Norwegian Institute for Air Research (EMEP/CCC-Report 1/93).

- Gehrig, R. and Baumann, R. (1993) Comparison of four different types of commercially available monitors for nitrogen oxides with test gas mixtures of NH₃, HNO₃, PAN and VOC and in ambient air. In: *EMEP Workshop on measurements of nitrogen-containing compounds. Les Diablerets, Switzerland, July 1992*. Lillestrøm, Chemical Co-ordinating Centre, Norwegian Institute for Air Research (EMEP/CCC-Report 1/93).
- Hesterberg, R. and Neftel, A. (1993) Problems with the Luminox detector LMA-3. In: *EMEP Workshop on measurements of nitrogen-containing compounds. Les Diablerets, Switzerland, July 1992*. Lillestrøm, Chemical Co-ordinating Centre, Norwegian Institute for Air Research (EMEP/CCC-Report 1/93).
- International Organization for Standardization (1985a) Ambient air - Determination of the mass concentration of nitrogen oxides-Chemiluminescence method. Geneve (ISO. International Standard 7996:1985).
- International Organization for Standardization (1985b) Ambient air- Determination of the mass concentration of nitrogen dioxide - Modified Griess-Saltzman method. Geneve (ISO. International Standard 6768:1985).
- Kelly, T. J., Spicer, C.W. and Ward G. F. (1990) An assessment of the Luminol chemiluminescence technique for measurement of NO₂ in ambient air. *Atmos. Environ.* 24A, 2397-2403.
- Pavlenko, A.A. and Volberg, N.S. (1979) Use of solid sorbents for determination of nitrogen oxides. *Trudy GGO*, 417, 105-112 (in Russian).
- Pavlenko, A.A. and Volberg, N.S. (1991) Determination of NO₂ in atmosphere using thin film sorbent for sampling. In: *EMEP Workshop on quality and comparability of atmospheric measurement data. Weilrod-Neuweilnau, Federal Republic of Germany, April 1991*. Lillestrøm, Chemical Co-ordinating Centre, Norwegian Institute for Air Research (EMEP/CCC-Report 5/91).
- Schiff, H. I., Mackay, G. I., Castledine, C., Harris, G. W. and Tran, Q. (1986) Atmospheric measurements of nitrogen dioxide with a sensitive luminol instrument. *Water Air Soil Pollut.*, 30, 105-114.

3.4 Sampling of sulphur dioxide, sulphate, nitric acid, ammonia, nitrate and ammonium using annular denuders

3.4.1.1 Introduction

The procedure for the determination of nitric acid and ammonia is based on the work of Allegrini et al., (1987, 1989, 1992) with some simplifications. It is suitable for the determination of nitric acid and ammonia in the concentration ranges 0–50 $\mu\text{g}/\text{m}^3$ $\text{HNO}_3\text{-N}$ and 0–5 $\mu\text{g}/\text{m}^3$ $\text{NH}_3\text{-N}$, respectively. If higher ammonia concentration levels are expected, the sampling procedure must be modified.

Since the denuders give a possibility to determine the individual concentrations of $\text{HNO}_3(\text{g})$ and $\text{NO}_3^-(\text{particle})$; and $\text{NH}_3(\text{g})$ and $\text{NH}_4^+(\text{particle})$ it is a recommended method to use in the EMEP network. A detailed discussion of using denuders contra filter pack is found in chapter [3.2.1](#).

3.4.1.2 Principle

The air is drawn through a series of annular denuders, and filters. The two first denuders are internally coated with sodium carbonate (Na_2CO_3) and glycerol for the collection of nitric acid and sulphur dioxide, the third is coated with citric acid, oxalic acid or phosphorous acid for the collection of ammonia. Evaporation of the coating layer can be a problem. A new study done on the efficiency of different coating layers to determine ammonia has shown that phosphorous acid is the most suitable denuder coating reagent (Perrino and Gherardi, 1999).

The coated denuders are then followed by a three-filter pack system. The first filter is a membrane filter with high collection efficiency for submicron particles, followed by a filter impregnated with potassium hydroxide for collection of nitric acid which may have evaporated from the particle filter, and a filter impregnated with oxalic acid for the collection of ammonia which may also have evaporated.

Nitrous acid (HNO_2) is also absorbed in the alkaline denuders, but will normally not cause a significant interference as it is usually detected as nitrite in the sample extracts. Glycerol prevents oxidation of nitrite to nitrate by ozone. Nitrogen dioxide and PAN is partially absorbed as nitrite, this interference in the eventual determination of nitrous acid may be corrected for from the distribution of nitrite between the first and the second denuder.

3.4.1.3 Sampling equipment

A schematic description of the sampling equipment is given in Figure 3.4.1. It consists of a small insulated box, with a fan for internal air circulation and provisions for heating to a temperature ~ 2 °C above the ambient temperature, and with a rack for mounting the denuder sampling trains and filter packs, electromagnetic valves connecting the sampling trains to a manifold, a leak-proof membrane pump which gives a sampling rate of 15 l/min, and a gas meter for recording of the sample volume. The electromagnetic valves activating each of the sampling trains are operated by means of an electronic timer. Denuder and filter pack sampling trains can also be activated and changed manually.

The sampling train consists of an air intake, 2 annular denuders of length 242 mm, and one denuder of length 120 mm. The denuders are connected by special threaded connectors, and capped with threaded caps when not in use. A special connect is used to connect the denuder train to a 3-stage filter pack containing an aerosol filter, a KOH-impregnated filter and a citric- or oxalic acid-impregnated filter. The pump and sample volume recording instrumentation is identical to the equipment described under 3.2.4.

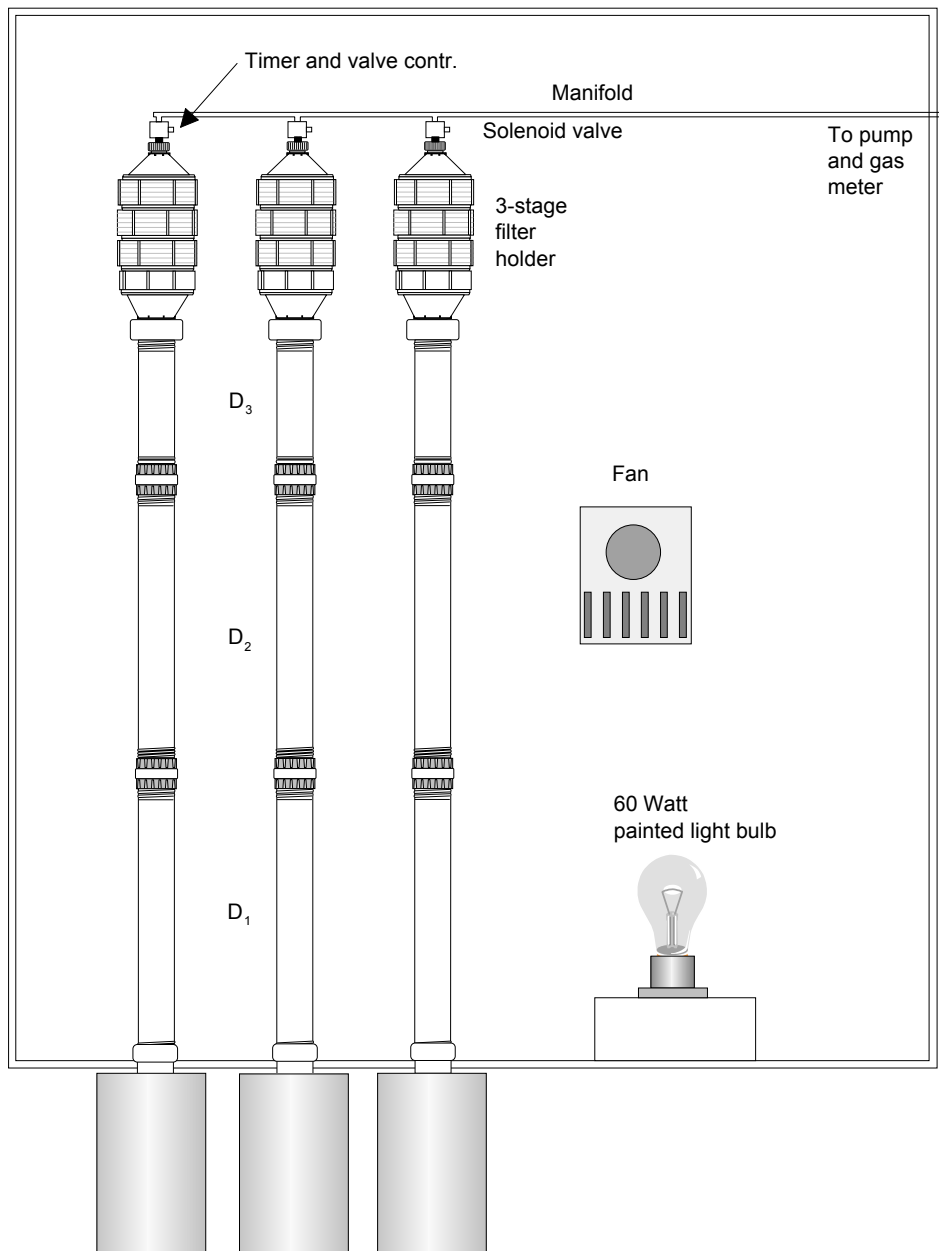

Figure 3.4.1: Sampling arrangement for denuder sampling. The number of sampling lines may be extended up to eight.

3.4.1.4 Commercial supply

Denuders:

242 mm URG-2000-30 BWH#30, annular denuder, heavy wall glass

120 mm URG-2000-30 BWH#30 as above

University Research Glassware, 118 E. Main St., P.O.Box 368 Carrboro, North Carolina 27510, USA.

3.4.1.5 Site requirements

See section [3.2.4.1](#)

3.4.1.6 Sampling procedure

Coating of denuders and preparation of filter packs

The preparation and coating of the denuders should take place in the laboratory that will carry out the chemical analyses of the collected samples. A solution of 1% Na₂CO₃ and 1% glycerol is prepared by dissolving 1 g of the analytical grade reagents in 50 ml of deionized water, and diluting to 100 ml with methanol. Similarly, 1 g of citric acid (or oxalic- or phosphorous acid) is dissolved in a few drops of deionized water and diluted to 100 ml with ethanol.

The denuders have to be thoroughly cleaned, preferably by immersion in strong detergent for several hours, and then rinsed in deionized water.

For the coating procedure, a source of clean, dry air is needed. Compressed air must be filtered, and may have to be scrubbed. Passing the air through 2 tubes filled with cotton or filter paper impregnated with, respectively, sodium carbonate and citric acid will be safeguards against contamination. It is also possible to use clean and dry nitrogen from a steel cylinder.

Put on a screw-thread cap on one end of the denuder, add 2–3 ml of the coating solution, and rotate the denuder so that all internal surfaces are wetted. Pour off excess liquid, take off the screw-cap and put on another cap with connection to the dry air source. Pass dry air through the denuder, while rotating the denuder slowly. Observe the evaporation of the liquid film, and continue for a few seconds more to make sure that the evaporation is complete. Close the denuder with screw-caps.

At least 3 of the denuders should be set aside for the determination of blank values for each batch of denuders, which is being prepared in this way.

(Alternatively, sodium chloride may be used as an internal coating for the absorption of nitric acid in D1 and D2. This absorbent may partly absorb SO₂ and will not absorb nitrous acid or PAN).

Preparation of impregnated filters with potassium hydroxide and with oxalic acid, and determination of filter blank values, is described under Section 3.2.8. Filter packs with impregnated filters should also be prepared and loaded in the laboratory, and sealed for transport to the sampling site. One set of denuders and one filter pack should be reserved for use as field blanks every week. These are to

be sent to the field sampling site, and returned to the laboratory without being exposed at the site.

Sampling

Denuders and filter holders will have been prepared and should be transported to the sampling site in special transport containers. They are to be connected to the sampling equipment according to specific instructions, and should be marked with sampling date and time period (from-to) and denuder number (D1, D2, D3) in the laboratory before transport to the site. Make sure that connections are leak proof. Denuder and filter pack trains should be changed at 0800h in the morning or a timer and magnetic valve arrangement should be used to make an automatic sampling train change at 0800h. The gas meter should be read or recorded every day, together with the temperature in the gas meter.

The temperature of the ambient air and the temperature inside the box holding the denuder trains, should also be checked periodically, to avoid overheating and to check that the system functions properly.

A sampling form should be filled in, with date and identification of denuders and filterpacks, gas meter readings, and notes of observations, which may be of interest in connection with the evaluation of the results.

The denuders and filter packs should be capped after exposure, and put in the container used for transport to the chemical laboratory (together with the field blanks).

3.4.1.7 Preparation of samples for chemical analyses

The following solutions are recommended for extraction of the denuders and the filters in the filter pack:

D1 (Na ₂ CO ₃ -imp)	10 ml deionized water with H ₂ O ₂ (0.3%)
D2 (Na ₂ CO ₃ -imp)	10 ml deionized water with H ₂ O ₂ (0.3%)
D3 (Citric acid)	10 ml 0.01M HNO ₃
F1 (aerosol filter)	10 ml deionized water
F2 (alkaline imp. filter)	10 ml deionized water with H ₂ O ₂ (3%)
F3 (oxalic acid filter)	10 ml 0.01 M HNO ₃

Unscrew the cap at one end of the denuder to be extracted, add exactly 10 ml of the extraction solution with a pipette, put on the cap and shake the denuder, then transfer the extract to a stoppered test tube for subsequent analysis. It is essential to work quickly in order to minimize contamination hazards! The filters may be folded and transferred to the same kind of stoppered test tubes to which 5 ml of extraction solution is added. Stopper and agitate shortly. If a hydrophobic (e.g. fluoropore) membrane filter is used as the first filter in the filter pack, immersion in an ultrasonic bath may be useful. Chemical analyses of the extracts are to be made as follows:

Sample	Ions to be determined	Analysis methods	Reference
D1	NO ₃ ⁻ -N, SO ₄ ²⁻ -S (Cl ⁻ , NO ₂ ⁻ -N)	Ion chromatography	Section 4
D2	NO ₃ ⁻ -N, SO ₄ ²⁻ -S (Cl ⁻ , NO ₂ ⁻ -N)	Ion chromatography	Section 4
D3	NH ₄ ⁺ -N	Spectrophotometry or ion chromatography	Section 4
F1	NO ₃ ⁻ -N, SO ₄ ²⁻ -S, NH ₄ ⁺ -N (Cl ⁻ , NO ₂ ⁻ -N)	Ion chromatography and spectrophotometry	Section 4
F2	NO ₃ ⁻ -N, SO ₄ ²⁻ -S (Cl ⁻ , NO ₂ ⁻ -N)	Ion chromatography	Section 4
F3	NH ₄ ⁺ -N	Spectrophotometry or ion chromatography	Section 4

3.4.1.8 Calculation of results

The results from the chemical analyses will be given in µg/ml of the respective ions. After subtraction of blank values, the following algorithm have been proposed by Allegrini et al. (1987) for the subsequent calculation of the concentrations of HNO₃-N, SO₂-S and NH₃-N in air:

$$\begin{aligned} \text{HNO}_3\text{-N } (\mu\text{g}/\text{m}^3) &= [(D1-D2)/0.94]*(10/V), \\ \text{SO}_2\text{-S } (\mu\text{g}/\text{m}^3) &= [(D1-D2)/0.96]*10/V, \\ \text{NH}_3\text{-N } (\mu\text{g}/\text{m}^3) &= D3*10/V, \end{aligned}$$

where D1, D2, and D3 stand for the concentrations of the relevant components in the respective denuder extracts and V is the sample air volume in m³. The correction factors are based on theoretically calculated absorption efficiencies and it is assumed that interfering particles and other substances (e.g. PAN) are collected with the same efficiencies in D1 and D2. Correspondingly:

$$\begin{aligned} \text{NO}_3\text{-N}(\text{particles}) &= (F1+F2+2.5*D2)*10/V, \\ \text{NH}_4\text{-N}(\text{particles}) &= (F1+F3), \\ \text{SO}_4\text{-S}(\text{particles}) &= (F1+2.5*D2). \end{aligned}$$

Note that if the absorption capacity of denuder D3 for ammonia is exceeded, F3 will retain gaseous ammonia, which has passed through the denuder system. Therefore, if this amount of ammonium-N collected on F1 and F3 is significantly larger than the equivalent amount needed to balance the nitrate and sulphate on F1 and F2, the calculated excess should be added to the NH₃-N concentration determined from D3.

3.4.1.9 Quality assurance

Sampling

Written step-by-step instructions for the handling of denuders and the operation of the sampling equipment should be available at the site, together with appropriate sampling forms for the registering of sampling flow rates, change of samples, and air sample volumes. The gas meter and flow control device must be properly calibrated in the laboratory. Field calibration of the flow rate and sample volume recording apparatus should be carried out at least once every year.

Chemical analysis

Field blanks should be analysed regularly in order to check on the possible contamination. It is recommended to prepare, and analyse, one complete sampling train every week. Field blanks are to be prepared in the same way as the other samples, sent to the site, and returned unexposed to the laboratory.

Control samples should be included in each batch of chemical analyses. The control samples should contain the same reagents as the leachates, and known realistic concentrations of the analytes. 5% control samples will generally be sufficient.

Data consistency

Sulphur dioxide and sulphate aerosol will generally be determined by a separate filter-pack sampler, as described in Section 3.2.1. Sulphur dioxide is also quantitatively retained in D1 and D2, and the sum of nitric acid and nitrate in airborne particles may be determined from the filter pack data. Comparison of the results will give a good indication of the performance of the complete sampling and analysis procedure. The results should generally be within $\pm 10-15\%$.

3.4.1.10 Comments with respect to the denuder sampling procedure

This sampling technique is technically demanding and requires good control of chemical analyses and particularly of blank values. The sampling set-up is relatively simple, but needs to be defined in relation to the sampling site and practical arrangements in connection with transport of unexposed denuder sampling trains and filter packs. The recommended denuder tubes are both expensive and brittle. Even more expensive denuder tubes are available, which are unbreakable. More information with respect to the theoretical and practical aspects of denuder sampling for the phase-separated determination of nitrogen species in air can be found in the literature described in the general introduction, reference is also made to a general review article by Ali et al. (1989).

The denuder sampling technique is applicable also to the determination of atmospheric HCl, HF and HNO₂, but these components are not included in the EMEP measurement programme.

The simple tubular denuder systems described by Ferm (1979, 1982, 1986) require much less expensive equipment. If blank values (including field blanks) and chemical analyses can be controlled, this system is an alternative to the system described above.

More advanced systems are also available, e.g. for continuous monitoring of gaseous NH₃ (Keuken et al., 1988)

3.4.1.11 References

Ali, Z., Thomas, C.L.P. and Alder, J.F. (1989) Denuder tubes for sampling of gaseous species. *Analyst*, 114, 759-769.

- Allegrini, I., de Santis, F., di Paolo, V., Febo, A., Perrino, C. and Pozzanzini, M. (1987) Annular denuder method for sampling reactive gases and aerosols in the atmosphere. *Sci. Tot. Environ.*, 67, 1-16.
- Allegrini, I., Febo, A., Perrino, C., eds. (1989) Field intercomparison exercise on nitric acid and nitrate measurements. Rome, September 18-24, 1988. Brussels, CEC (Air Pollution Research Report, 22).
- Allegrini, I., Febo, A., Perrino, C., eds. (1992) Field intercomparison exercise on ammonium measurement. Rome, April 29-May 4, 1990. Brussels, CEC (Air Pollution Research Report, 37).
- Ferm, M. (1979) Method for determination of atmospheric ammonia. *Atmos. Environ.*, 13, 1385-1393.
- Ferm, M. (1982) Method for determination of gaseous nitric acid and particulate nitrate in the atmosphere. EMEP Expert meeting on chemical matters, Geneva 10-12 March.
- Ferm, M. (1986) A Na_2CO_3 -coated denuder and filter for determination of gaseous HNO_3 and particulate NO_3^- in the atmosphere. *Atmos. Environ.*, 20, 1193-1201.
- Hering, S.V. et al. (1988) The nitric acid shootout: field comparison of measurement methods. *Atmos. Environ.* 17, 2605-2610.
- Keuken, M.P., Schoonebeek, C.A.M., van Wensveen-Louter, A. and Slanina, J. (1988) Simultaneous sampling of NH_3 , HNO_3 , HCl , SO_2 and H_2O_2 in ambient air by a wet annular denuder system. *Atmos. Environ.*, 22, 2541-2548.
- Perrino, C. and Gherardi, M. (1999) Optimization of the coating layer for the measurement of ammonia by diffusion denuders. *Atmos. Environ.*, 33, 4579-4587.
- Stelson, A.W. and Seinfeld, J.H. (1982) Relative humidity and temperature dependence of the ammonium nitrate dissociation constant. *Atmos. Environ.*, 16, 993-1000.

3.5 Cleaning and impregnation of filters

See sections [3.2.7](#) and [3.2.8](#).

3.6 Extraction from filters

See section [3.2.9](#).

Pages 3-44 to 3-50 in earlier revision is included in the previous pages.

3.7 Determination of light hydrocarbons in air

3.7.1 Introduction

The EMEP-Workshop on measurements of hydrocarbons/VOC in Lindau 1989 recommended C2 to C5 hydrocarbons to be measured in spot-samples taken twice a week at 10 to 15 sites in Europe. Electropolished stainless steel canisters were recommended for the sampling.

3.7.2 Principle

A cleaned steel canister is flushed with air and then filled to a pressure about 40 psig (2.8 atm). The canister is brought to a laboratory and analysed within a week.

3.7.3 Sampling equipment

The sample cylinders are 1.8 litre "Summa" polished stainless steel canisters manufactured by Prof. R. Rasmussen. The clean air pump is from the same supplier. Both cylinders and pumps were widely used and tested in both USA and Europe. A number of tests and comparisons with other equipment have been undertaken, and are published in several articles and intercalibrations (McClenny et al., 1991; Pate et al., 1992; Westberg et al., 1984; Olivier et al., 1986).

3.7.4 Sampling procedure

See Figure 3.7.1.

1. Can is evacuated
2. Remove swagelock-end-cap
3. Connect purge-tee and tighten
4. Switch on pump
5. Pressurize purge-tee
 - Vent by opening valve B
(minimum 10 times)
6. Open valve A - pressurize can to 15 psig
 - Vent by opening valve B
(minimum 5 times)
7. Pressurize can to max. pressure (about 40 psig)
8. Close valve A and switch off pump
9. Remove purge-tee and replace swagelock

Please use a pencil to fill in the label.

Please do not use force to tighten the green handle of the shut-off valve. Normal use of thumb and forefinger is sufficient!!

3.7.5 Cleaning of canisters before the first use

- (1) evacuate to a pressure of 10^{-7} mbar 24 hours, ambient temperature.
- (2) fill with 10 μ l water and purified helium 24 hours, 1 bar
- (3) evacuate to 1 mbar and fill with helium 5 times
- (4) humidify with 10 μ l water, evacuate to 1 mbar

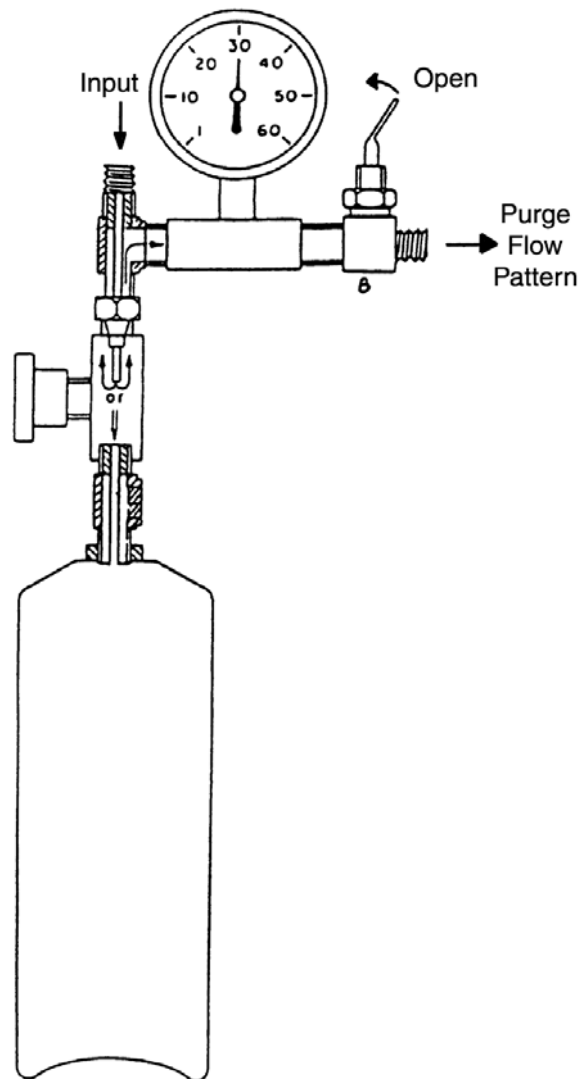

- 1 Can is evacuated
- 2 Remove swagelock-end-cap
- 3 Connect purge-tee and tighten
- 4 Switch on pump
- 5 Pressurize purge-tee
 - Vent by opening valve B
(minimum 10 times)
- 6 Open valve A - pressurize can to 15 psig
 - Vent by opening valve B
(minimum 5 times)
- 7 Pressurize can to max. pressure (about 40 psig)
- 8 Close valve A and switch off pump
- 9 Remove purge-tee and replace swagelock

Please use a pencil to fill in the label.

Please do not use force to tighten the green handle of the shut-off valve. Normal use of thumb and forefinger is sufficient!!

Figure 3.7.1: Sampling procedure.

After step (1) a one-hour leak-test is performed. The canister shut-off valve is closed and no detectable increase of pressure should occur on the 10^{-7} mbar scale.

Blank runs of canisters should not show a single signal of more than 2000 μ Vs (30 ppt ethane or 10 ppt benzene).

From the 200 canisters we bought for the EMEP-program, 7 had a significant high level of C₆ hydrocarbons and chlorinated solvents. Those bottles were cleaned with methanol, acetone and water and cleaned as shown above. The evaporation in step (1) is performed with 70 °C instead of ambient temperature. The cleaning of a used bottle is done by 6 to 24 hours evacuation at 10^{-7} mbar and 50°C. (Turbomolecular pump from Pfeiffer Balzers modified at NILU to allow simultaneous cleaning of 6 bottles).

3.7.6 Commercial supply

Steel canisters:

Prof. R. Rasmussen, Oregon Graduate Center, Biospheric Research Cooperation.

3.7.7 References

McClenny, W.A. et al. (1991) Canister-based method for monitoring toxic VOCs in ambient air. *J. Air Waste Manage. Assoc.*, 41, 1308-1318.

Pate, B. et al. (1992) Temporal stability of polar organic compounds in stainless steel canisters. *J. Air Waste Manage. Assoc.*, 42, 460-46.

Westberg, H. et al. (1984) Analysis of individual hydrocarbon species in ambient atmospheres. In: *Identification and analysis of organic pollutants in air*. Ed. by L.H. Keith. Woburn, MA, Butterworth. pp. 323-327.

Olivier, K.D. et al. (1986) Sample integrity of trace level volatile organic compounds in ambient air stored in summa polished canisters. *Atmos. Environ.*, 20, 1403-1411.

3.8 Determination of aldehydes and ketones in ambient air

3.8.1 Introduction

Recent years several methods for simultaneous determining of aldehydes and ketones in air have been investigated. The most popular method so far utilizes a solid adsorbent coated with 2,4-dinitrophenylhydrazine (DNPH), and the resulting derivatives are subsequent analysed by high performance liquid chromatography and UV detection, e.g. Slemr (1991). This method has been modified for use in EMEP, and the procedure is described below.

The range of concentrations of the individual aldehydes and ketones which may be determined is typically from 0.1 $\mu\text{g}/\text{m}^3$ to 10 $\mu\text{g}/\text{m}^3$.

The detection limit of a typically sample (sample volume 750 litres) lies in the range 0.01 $\mu\text{g}/\text{m}^3$ –0.05 $\mu\text{g}/\text{m}^3$. Preliminary results from parallel sampling at Birkenes give a relative standard deviation of 6% for methanal (mean 0.30 $\mu\text{g}/\text{m}^3$) and propanone (mean 0.99 $\mu\text{g}/\text{m}^3$, and 12% for ethanal (mean 0.42 $\mu\text{g}/\text{m}^3$).

3.8.2 Principle

The air sample is drawn through a cartridge which contains 2,4-dinitrophenylhydrazine (2,4-DNPH)-coated silica packed in a polyethylene tube. Aldehydes and ketones react with the acidified 2,4-DNPH to form the corresponding hydrazones.

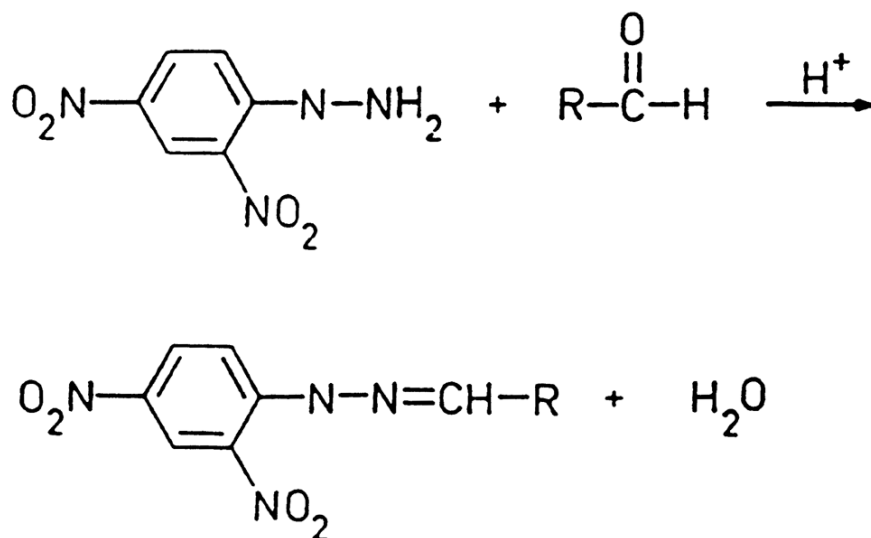

Figure 3.8.1: Reaction scheme.

After exposure the cartridge is eluted with acetonitrile, and the sample extract is analysed by reversed phase high-performance liquid chromatography, using UV-detection (diode array detector). The detection and quantification is carried out at 369 nm (band width 22 nm) using 474 nm (band width 50 nm) as the reference wavelength. The detection and quantification of dicarbonyls is carried out at 440 nm (band width 22 nm) using 337 nm (band width 50 nm).

3.8.3 *Sampling equipment*

- Sep-PAK DNPH-silica cartridges
- Air sampling pump, model DOA-p101-BN
- Gas meter, FLONIDAN, Gallus 2000 G1.6
- Copper tubing, length 1 meter, i.d. 0.46 cm

3.8.4 *Commercial supply*

Absorption tubes:

Sep.-PAK DNPH-silica, cartridges, No. 37500
Waters, Millipore Corporation
Waters Chromatography
Millford, MA, USA.

Membrane pump:

GAST, Model DOA-P101-BN
MFG Corp.,
Benton Harbor, Mich. USA

Gas meter:

FLONIDAN
Gallus 2000 G1.6
Islandsvej 29
DK-8700 Horsens, Denmark

The sampling equipment set-up is shown in Figure 3.8.2. The threads in the pump inlet, pump outlet, and gasmeter inlet require use of teflon tape to get the connections leakproof. Be careful and do not overtighten the connections!

Before use, the equipment should be leakproof-tested and tested for appropriate air flow rate (typically 1.5 litres/min–2 litres/min).

Leakproof-test: Plug the air inlet PE-tube with a male Luer plug (or your thumb) and start the pump. Keep the sampling line plugged for 2 minutes. During this time period the gas meter reading should be constant.

Air flow rate test: Connect the DNPH-silica cartridge (connect a cartridge which has been used and dried) to the air inlet tube (as shown in Figure 3.8.3) and start the pump. Measure the "sample" volume over a period of 5 to 10 minutes and calculate the flow rate in litres/min. If necessary adjust the needle valve until you have a flow rate of 2 litres/min or as high flowrate as possible not exceeding 2 litres/min (sometimes the cartridge-restriction makes it impossible to reach 2 litres/min).

3.8.5 *Preparation of ozone-scrubber*

Form a coil from a copper tube (1 meter, 0.46 cm i.d.). Fill the coil with a potassium iodide solution (dilute a saturated aqueous potassium iodide solution 1:1 with water) for 5-10 minutes. Drain the coil and dry it completely by passing nitrogen through the coil.

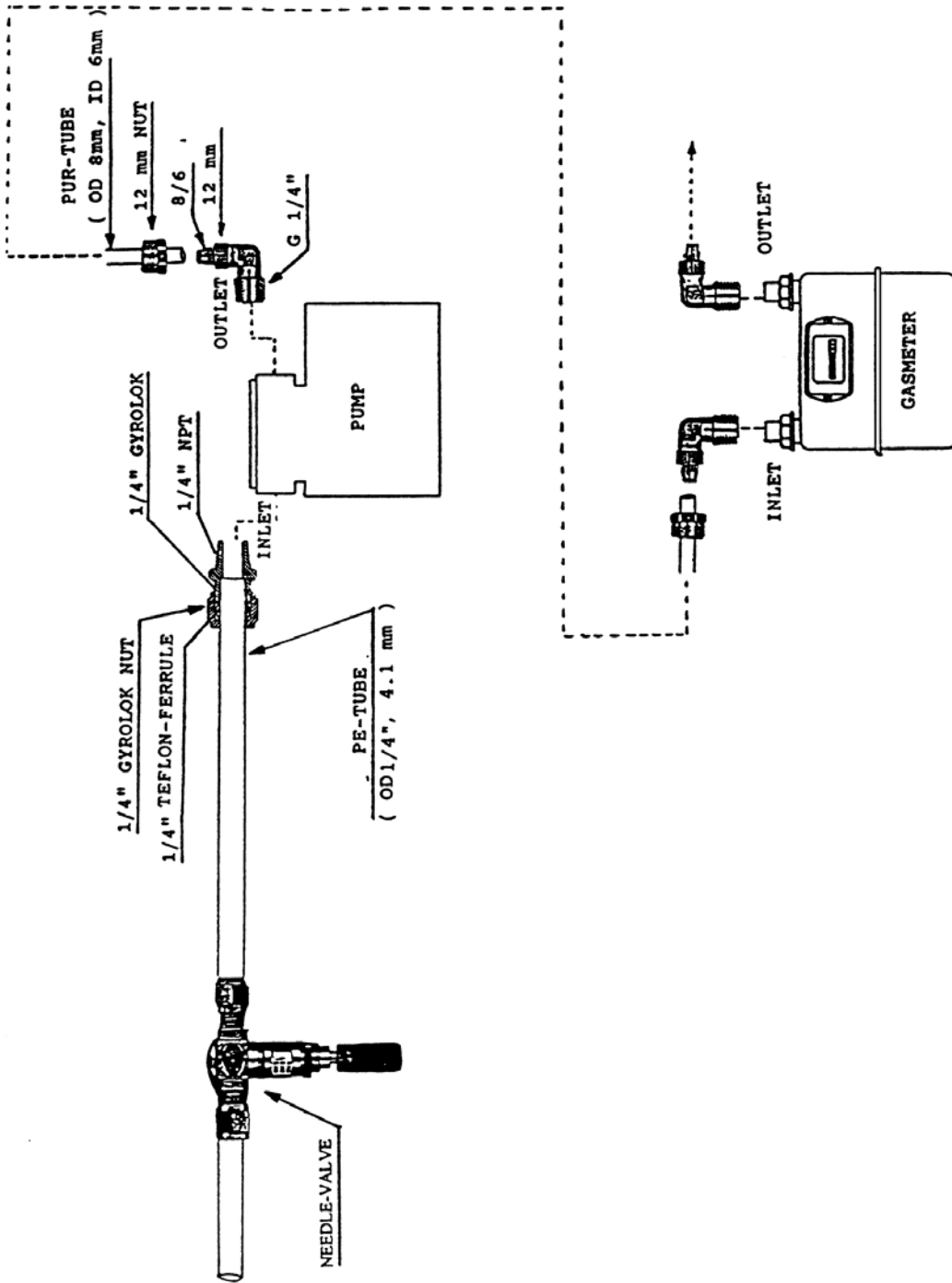

Figure 3.8.2: Sampling equipment set-up.

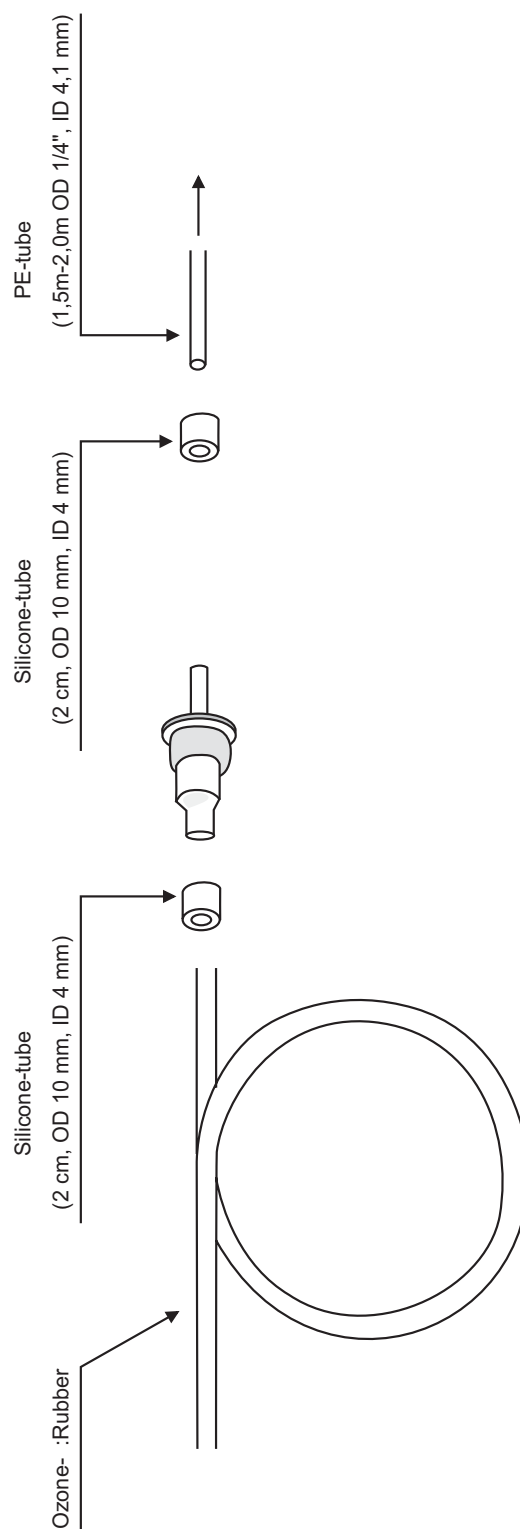

Figure 3.8.3: The figure shows how DNP-silica cartridges and the ozone-scrubber are connected to the pump inlet polyethylene (PE) tube.

3.8.6 Sampling procedure

- The samples should be taken on Mondays and Thursdays from 0800 to 1600 hours local time.
- Sample information should be carefully recorded in the sampling form. The sampling form must follow the sample as an identification when the sample is sent to the laboratory. Each glasscontainer should be marked with "sample name" (Sample name = Station name, sampling date (example: London, 15/5-93 = 15 May 1993)).

The "cookbook":

1. Record the following in the sampling form: Batch number (= Lot No.) of the sample cartridge, ozone scrubber number, sample name, outdoor temperature, indoor temperature, sampling technique and signature.
2. Remove the endcaps from the ozone scrubber.
3. Open the sealed pouch which contains the cartridge. Remove the Luer plug and cap and keep them in a place where they do not disappear (you need the plug and cap for sealing the cartridge after completed sampling).
4. Connect the ozonescrubber, cartridge, and the PE-tube in the manner shown in Figure 3.8.3. (The ozone scrubber should be mounted upstream of the cartridge.) The male Luer tip of the cartridge has to enter the PE-tube ("edge-to edge"), in such a way that the silicon tube becomes a support and not the main seal (then there will be no contact between the exhaust and the silicon tube).
5. Install the sampling equipment in sampling position.
6. Record the following in the sampling form: gasmeter reading and sampling start time. Then turn on the sampling equipment.
7. After a run time of 5-10 minutes optimize the flow rate.
8. Seal the cartridge with Luer cap and plug after completed sampling.
9. Record the following in the sampling form: gasmeter reading and sampling end time.
10. Seal the ozone scrubber with end caps.

In order to avoid the potassium iodide film being dissolved by water, a weather-protection "device" has to be mounted on the scrubber (teflon funnel or the upper half of a teflon bottle).

3.8.7 *Sampling handling*

- "Stock-cartridges" should be stored in the sealed pouches at 4°C.
- After completion of the sampling, the exposed cartridges should as soon as possible, be disconnected from the sampling line and sealed with the Luer plug and cap.
- The cartridges are put into glass containers with teflon lined screw-caps.
- *Label the glass containers* by using the sample name written on a self-adhesive label. The glass containers are then put into plastic containers and sent to the laboratory.
- If the exposed cartridges have to be stored for some days, it should be done in dark at a cool place (4°C), i.e. a refrigerator. **Do not store the cartridges at places where carbonyls are stored (acetone etc.).**

3.8.8 *Procedure for blank sample preparation*

1. After preparing the sampling equipment for sampling, open a sealed pouch with same batch number as the sample batch number.
2. Record the following in the sampling form: Batch number (= Lot No.) of the blank sample cartridge, starting time (= opening time for the pouch), sample name (= same as "real" sample name), indoor temperature and signature. Instead of recording gasmeter readings and sampling end time "BLANK" should be noted in the sampling form.
3. Place the cartridge nearby the sampling equipment during sampling. Do not remove the end cap and plug.
4. After completion of the real sampling the blank sample cartridge should be treated in same manner as the real sample. *Label the glass container with "sample name" and BLANK.*
5. The blank sample cartridge has to be mailed together with the real sample *in the same envelope*. Please do remember that the sampling forms have to be mailed together with samples.

3.8.9 *References*

Dye, C. and Oehme, M. (1992) Comments concerning the HPLC separation of acrolein from other C₃ carbonylcompounds as 2,4-Dinitrophenylhydrazones: A proposal for improvement. *J. High Resolut. Chromatogr.*, 15, 5.

Millipore Corp. (1992) Waters Sep-Pak DNPH-Silica Cartridge; Care and Use Manual. Milford, USA, Waters Chromatography Publications.

Slemr, J. (1991) Determination of volatile carbonylcompounds in clean air. *Fresenius J. Anal. Chem.*, 340, 672.

3.9 Determination of ozone

3.9.1 Introduction

Both chemiluminescence and UV-absorption based methods have been used in the past 20 years for the measurement of ozone in ambient air. After many years of discussion and intercomparison between different wet-chemical methods for calibration of ozone generators used for calibration of the monitors, it is now generally accepted to use UV-photometry as the primary calibration method. Since the UV-absorption method has proven to be reliable and robust in field operations, this method is recommended and described in this manual. The description follows the principles from the International Organization for Standardization (ISO) (ISO 13964:1998).

The general requirements to regional sites are valid for ozone. In addition ozone is a reactive gas that is taken up by vegetation; measurements should therefore be carried out well away from plant life. The Canadian networks recommend sampling at 3-5 m above ground level and more than 20 m away from trees.

Details in the operating procedures for the O₃-instruments will be found in the Operator Manual for the different commercial monitors.

3.9.2 Field of application

The described method is applicable for continuous monitoring of ozone (O₃) in ambient air. The method can be used in the range 2 µg/m³ to 2 mg/m³ (1-1000 ppb).

3.9.3 Principle

Sample air is drawn continuously through an optical absorption cell where it is irradiated by monochromatic light at 253.7 nm from a stabilized low-pressure Hg discharge lamp. The absorption of this radiation by the sample air is a measure of the ambient air ozone concentration. To avoid interference from other gases absorbing light at the same wavelength and from instability in the light source, an ozone catalytic converter is used to selectively remove ozone from the sample stream either in the sample cell by alternately fill the sample cell with unscrubbed and scrubbed sample air, or by using another parallel sample cell.

The Beer-Lambert equation, shown below, is used to calculate the concentration of ozone from the ratio of the two light intensities measured:

$$I/I_0 = \exp(-acd)$$

where

- I_0 is the light intensity measured with no ozone in the gas sample
- I is the light intensity measured with ozone in the gas sample
- a is the ozone absorption coefficient at 253.7 nm ($1.44 \times 10^{-5} \text{ m}^2/\mu\text{g}$)
- c is the mass concentration of ozone in µg/m³
- d is the optical path length in m

UV photometry is also the recommended primary calibration procedure. The use of transfer standards (including non-UV methods) is possible if they have been previously calibrated against the primary UV photometric method.

3.9.4 Reagents and materials

Sampling line

The sampling line shall be made of material that is inert to ozone, such as glass or fluorocarbon polymer and shall be as short as possible to keep the residence time to a minimum. Any ambient nitric oxide present in the sample air will react with some of the ozone during the residence time in the sampling line. The sampling line or manifold shall be clean and should normally be replaced after one year. If high amount of dust deposition in the sampling line is expected, it should be cleaned or replaced more frequently.

Particle filter

The sample air has to be drawn through a filter before entering the absorption cell. The filter and its support shall be made of material inert to ozone, such as fluorocarbon polymer, and shall remove all particles likely to alter the performance of the analyzer. It shall be changed on a regular basis, depending on the ambient particle concentrations at the sampling site. This is necessary because excessive accumulation of particles on the filter can cause loss of ozone from the sample air and an excessive pressure drop across the filter.

Normally, a filter pore size of 5 μm is used.

Generally, new filters need some time to be conditioned, and the first 5-15 minutes data after the filter change should be discarded.

Zero air

Zero air is required in the analyzer calibration procedure. The zero air shall be free of ozone, nitrogen oxides and any other interfering substance that can cause a positive or negative response in the UV photometer. The zero air supplied to the photometer during the I_0 measurement shall be the same as that used for generation of calibration ozone concentrations.

If synthetic air is used, the oxygen content shall be within 2% of the normal atmospheric concentration.

Details on a system for making zero air from ambient air is found in EPA (1979a).

3.9.5 Apparatus

3.9.5.1 UV photometric ambient ozone analyzer

The components of a typical UV photometric ozone measuring system are shown in Figure 3.9.1. The monitor should have specifications as listed below:

Range	: 0.002–2 mg/m^3
Output	: 0–10V full scale
Lag time	: 20 s

Rise time	: 15 s
Fall time	: 15 s
Warm-up time	: 2h
Zero instability	: $\pm 2 \mu\text{g}/\text{m}^3$ per week
Span instability	: $< 0.5\%$ per week
Repeatability	: $\pm 2 \mu\text{g}/\text{m}^3$
Period of unattended operation	: 7 d
Sample flow rate	: 1.5–2 l/min
Temperature range	: 0–45 °C

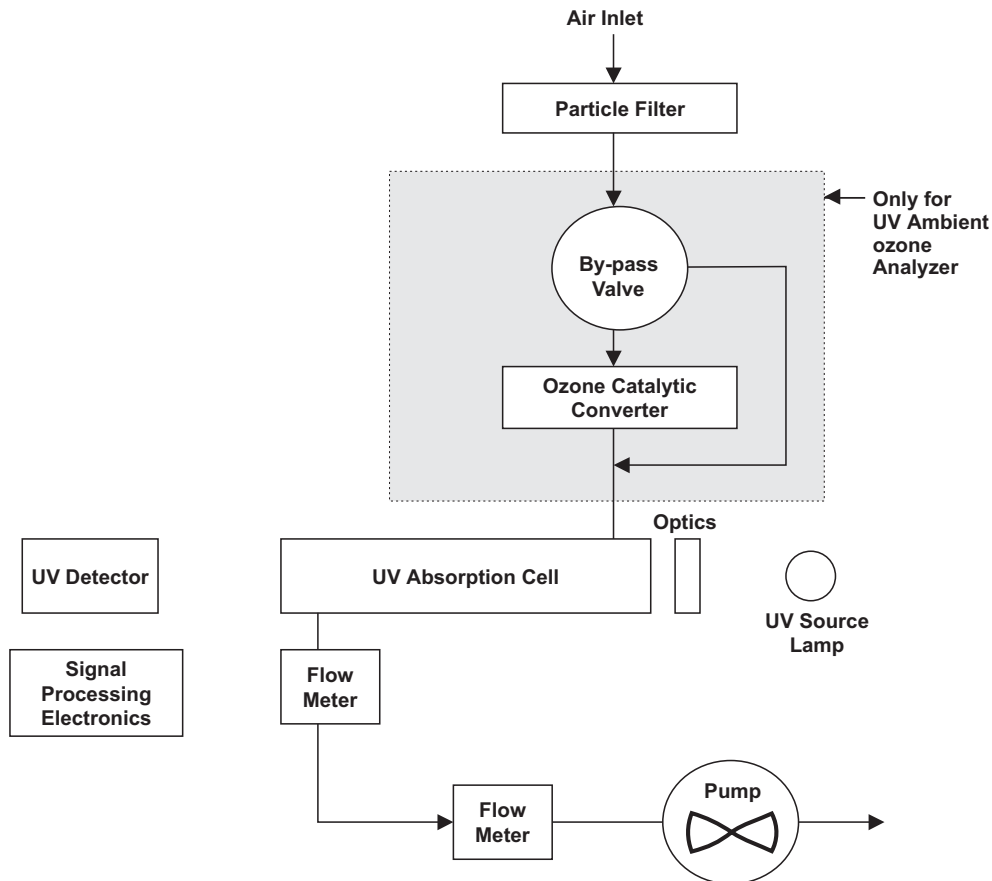

Figure 3.9.1: UV photometric ozone measurement system.

Commercial instruments that meet these specifications are readily available.

One important component of the instrument is the ozone-specific scrubber. Normally, instrument manufacturers give an average lifetime of such scrubbers, however, the actual lifetime will depend on the concentration of other pollutants at the sampling site. A scrubber failure will give a decrease in response to ozone.

Since the ozone absorption coefficient given in the formula in Section 3.9.3 is dependent of temperature and pressure, it is important that the instruments have temperature and pressure indicators capable of measuring the temperature and

pressure in the absorption cell with an accuracy of $\pm 0.1^\circ\text{C}$ and $\pm 0.1\text{kPa}$ respectively.

3.9.5.2 Apparatus for calibration

A simplified scheme of a primary ozone calibration system is shown in Figure 3.9.2 and consists of an ozone generator and a UV calibration photometer.

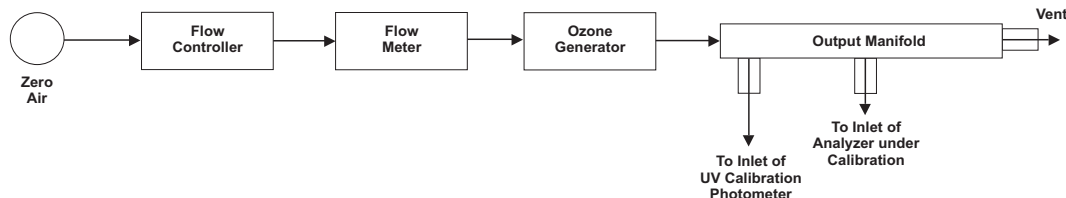

Figure 3.9.2: Primary ozone calibration system.

Primary UV calibration photometer

The primary UV calibration photometer shall be used for only that purpose and shall be carefully maintained under stable laboratory conditions. The different parts of the calibration photometer are the same as shown in Fig. 3.9.1 but without the catalytic ozone scrubber. Every part shall be manufactured optimum care.

When using the expression **primary** calibration photometer in this section, it will normally mean a laboratory or e.g. a country's primary calibration photometer. Such primary calibration photometers should preferably be traceable to the NIST (US National Institute of Standards and Technology) UV-photometer. One way of obtaining this is to buy from NIST a NIST-UV photometer which periodically will be checked by NIST. Another way is to have the laboratory or national primary calibrator calibrated against a NIST-UV photometer in another country e.g. once per year. To the CCCs knowledge there are at least three NIST-UV photometers in Europe:

Institute of Applied Environmental Research at the University of
Stockholm,

Air Pollution Laboratory, Stockholm, Sweden

Phone : + 46 8 674 70 00

Fax : + 46 8 612 08 49

Swiss Federal Laboratories for Materials Testing and Research (EMPA),
Dübendorf, Switzerland

Phone : + 41 1 823 55 11

Fax : + 41 1 821 62 44

Czech Hydrometeorological Institute

Prague, Czech Republic

Phone : +42 2 401 6719

Fax : +42 2 401 0800

Ozone generator

This apparatus generates the stable ozone concentrations that are measured by the calibration photometer described above. It shall be capable of producing steady ozone concentrations in the range of interest at the required flow rate and throughout the calibration period. If a variable ozone generator is not available, the calibration system shall include a means of diluting the ozone with additional zero air, and a mixing chamber shall be installed before the output manifold.

Output manifold

The output manifold shall be of materials inert to ozone, such as glass or fluorocarbon polymer. It shall be of sufficient diameter and be vented to ensure equal pressure inside and outside the manifold. The vent shall be located so as to prevent intrusion of ambient air.

Procedure

In the next paragraphs the principles for the measurement and calibration procedures are described.

Operation of the ambient ozone analyzer

Install the instrument in a suitable location. The room for the analyzer shall be temperature controlled. For background ozone measurements, local sources of nitric oxide have to be avoided as it readily react with ozone. The air intake should be positioned at least 2 m above ground.

Follow the manufacturers instructions for the specific analyzer to set correctly the various parameters, including UV source lamp intensity, sample flow rate and activation of the electronic temperature/pressure compensation.

Introduce sample air into the instrument and record the ozone concentrations by means of a suitable recording device.

During continuous operation, checks on the instrument zero and operational parameters shall be made at least once per week. If an internal ozone source is available in the monitor, this can be used for a span check, but is normally not stable enough for making calibrations. It is recommended that a multipoint calibration be carried out every 3-4 months.

3.9.5.3 Calibration of the ambient ozone analyzer***Principle***

The calibration system is shown in Figure 3.9.2. Various ozone concentrations (in air) are generated and accurately measured with the primary UV calibration photometer. These ozone calibration concentrations are simultaneously sampled by the ambient ozone analyzer to be calibrated via a common manifold. The analyzers response is plotted against the ozone concentrations measured by the primary UV calibration photometer.

Alternatively, a transfer standard calibration method can be calibrated against the primary ozone standard and then used to calibrate the ambient analyzer at the sampling location.

More details for the calibration procedure are given in EPA (1979a) and in the instrument manuals.

Transfer standard calibration procedure

A transfer standard has to be used whenever the primary calibration photometer is not readily available such as at the sampling site.

The transfer standard shall be calibrated against the primary UV photometric standard at least once per year and its accuracy shall be maintained within $\pm 5\%$ between successive primary calibrations.

The recommended (portable) transfer standard calibration method is a second UV photometer system with its own zero air and ozone supply. The other acceptable transfer standard calibration methods are the gas-phase titration of excess nitric oxide by ozone (or vice versa) and the laboratory-based neutral buffered iodide-potassium bromide (KIBR) method. For details see EPA (1979b).

3.9.6 Cooperation with WMO GAW on surface ozone measurements

WMO has produced a quality assurance plan for surface ozone including standard operating procedures (WMO GAW No. 97). WMO GAW and EMEP are trying to harmonize and will hopefully adopt the same SOPs, and cooperate with respect to audit and calibration.

3.9.7 References

EPA (1979a) Technical assistance document for the calibration of ambient ozone monitors. Research Triangle Park, N.C., United States Environmental Protection Agency (EPA-600/4-79-057).

EPA (1979b) Transfer standards for calibration of air monitoring analyzers for ozone. Research Triangle Park, N.C., United States Environmental Protection Agency (EPA-600/4-79-056).

WMO (1994) Quality assurance project plan for continuous ground based ozone measurements. Prepared by GAW QA/SAC. Geneva (WMO GAW No. 97).

3.10 Sampling of heavy metals in precipitation

3.10.1 Introduction

The Protocol to the Convention on long-range transboundary air pollution (LRTAP) on heavy metals was signed on 24th of June 1998 in Aarhus in Denmark. It targets three particularly harmful metals: cadmium, lead and mercury. According to one of the basic obligations, Parties will have to reduce their emissions of these three metals below their levels in 1990 (or an alternative year between 1985 and 1995). The main sources for atmospheric deposition of heavy metals are mines, smelting plants and metal industry of various types as well as burning of coal and other fossil fuels. Additive of lead in gasoline is historically one significant source of lead; however, international agreements have decreased this problem.

From 1999, heavy metals have been part of the EMEP program; and it is therefore a need for harmonisation and standard procedures for sampling and analysis of heavy metals. The recommendations are mainly based on previous work of EMEP (NILU and IVL, 1993) and the conclusions from the EMEP and WMO-GAW workshops in Durham, Beekbergen, Moscow and Aspenäs (EMEP, 1993; EMEP, 1996b; EMEP, 1997a; EMEP, 1997b) and at the two first task force of measurements and modeling, TFMM (EMEP, 2000).

Due to the special properties of mercury, this needs a different sampling technique than the other elements and separate chapters have been written for sampling of mercury, chapter [3.12](#).

3.10.2 Siting criteria

Generally, as for the main components, the heavy metal measurements should not be influenced by emissions from local sources nor by local circulation effects and formation of stagnant air pockets, which cannot be reproduced in the regional scale models. The siting should follow the criteria written in Chapter [2](#); in addition, further precautions have to be taken to prevent local sources as e.g. metal dust from pumps, metal surfaces, building materials, paint etc.

3.10.3 Sampling procedure

The sampling of heavy metals follows to a large extent the same procedures as for the main components in precipitation, Chapter [3.1](#), but due to the sensitivity for contamination extra precautions are needed. The concentrations of heavy metals in precipitation are typically only a few nanograms per millilitre and it is important that the standard procedures are followed carefully.

3.10.3.1 Equipment

It is recommended to use a wet only collector for precipitation sampling. When choosing which wet-only sampler to use, it is important that no parts of the precipitation collector are made of metal. Further that all parts can easily be cleaned and be of known composition. As for material, high-density polyethylene collectors are recommended. Among good wet-only collectors are the ARS type

from Eigenbrodt in Germany and the one from MISU in Sweden. Other wet only collectors can be used if they have proven to be of the same or better quality.

Different sampler designs have different sampling efficiency, which may lead to incomparable results when calculating the wet deposition. A parallel measurement of precipitation amounts should be made to identify any discrepancies. It is strongly recommended to use a rain gauge in parallel with the sampling equipment. The difference in precipitation amount between the two collectors should not be greater than 10%. If systematic errors are found, the sampler design should be reconsidered. The precipitation amounts from both collectors should be reported to CCC.

Bulk collector may be used when proven to be quantitatively equivalent to the recommended method. Bulk collectors tend to give too high metal concentrations due to dry deposition, but in some areas there are practically no difference between the two types of collector i.e. in the Nordic countries. When a bulk collector can be used, it is recommended to use a sampler with separate collective funnel and collection bottle for easy cleaning. In addition the funnel should have high walls. Some of the traditional bulk collectors have a metal ring in the top; this has to be taken away before it can be used for heavy metal sampling. If a bird ring is needed it should be made of polyethylene. In the field comparison of heavy metals in precipitation performed in Deuselbach Germany in 1995 a variety of different bulk precipitation collectors were compared (Winkler and Roider, 1997). It was discovered that the use of a fine meshed net (<1 mm) in the funnel neck caused troubles with wetting loss, sometimes hindered water from draining into the bottle and caused difficulties in sealing the funnel and bottle. It is therefore recommended to avoid using this type of net. However, in order to prevent insects leaves etc. to enter the collection bottle one can use a sieve made of i.e. polycarbonate with larger grid size. The sieve should be free and not tied up in the funnel neck. The sieve can for example just be the filter backing used in the filter folder system. For sites with snow in wintertime it is recommended to use the rain sampler also in this season, since a snow collector (cylindrical bucket) are difficult to clean thoroughly. However, for places with extremely much snow and strong wind it might be necessary to use a snow collector in the wintertime.

3.10.3.2 Cleaning

The concentration of heavy metals in precipitation samples and extracts from filters are very low, in the interval 0.01-10 ng/ml. Therefore, it is very important that all the equipment are thoroughly cleaned to prevent contamination. The precipitation bottles should be thoroughly cleaned between use. They should be stored minimum one day in 2% nitric acid and then washed several times (minimum three times) with de-ionized water, dried corked and packed in two clean plastic bags and zipped until used in the field. All reusable lab-ware should be cleaned in the same manner. The funnels should be washed in the field between every sampling and every month sent to laboratory for more thorough cleaning.

3.10.3.3 *Standard operating procedure*

Sample bottles, measuring equipment etc should always be handled with care to prevent contamination. Plastic gloves should be used when collecting the samples and the inside of the funnel or the tip of the collector should not be touched. All bottles should be kept in double plastic bags during transport and storage. The station observer must wear clean clothes that do not give any dust or other kind of pollution.

In order to prevent contamination, the precipitation bottle should be sent directly to the laboratory without transferring any precipitation into smaller transport bottles, which are usually done when measuring the main components in precipitation. Immediately after disconnection the sample bottle must be closed e.g. with a screw cap and sent to the laboratory. The precipitation amount is measured by weight. The empty sampling bottle with screw cap is weighed before use and then weighed after the sampling period is finished.

The precipitation must be conserved in nitric acid which is added either before or just after (Chapter [3.10.4](#)) the sampling. To prevent growth of algae in the sample the acid should be added before the precipitation sampling. Before sending the precipitation bottle to the field it should then be filled with e.g. 2 ml concentrated HNO₃. Choosing this sampling strategy it is, however, important to consider whether i.e. a possible evaporation of nitric acid may influence other measurements at the site.

Some trace metals may absorb on the surface of the funnel. Therefore, the funnel should be washed with an exact volume (200 ml) of acidic water (1% HNO₃), which is collected in a separate collection bottle. This is analysed to study the influence of absorption. This is especially important in the beginning of the sampling program, and if it turns out to have a significant influence this needs to be included in the sampling procedure as written in cursive below.

The standard sampling procedure is:

- Bring an empty clean precipitation bottle and screw cap to the precipitation sampler.
- Disposable polyethylene gloves are put on. One should change to new plastic gloves if touching the inside of the funnel is necessary.
- Disconnect the precipitation bottle and put on the screw cap.
- Examine the collector funnel for visible contamination such as insects, leaves or tree-needles, organic debris. If this is found, remove the contamination.
- *Wash the funnel using 200 ml acidic (1% HNO₃) water. Let it run into a separate bottle. Disconnect this bottle and set the screw cap on.*
- Without any collection bottle in place rinse the funnel twice using deionized water (\approx 100 ml) and let the water drain off.
- Connect the new clean precipitation bottle.
- The precipitation bottle (*as well as the bottle with the 200 ml acidic rinsing water*) is (*are*) put in separate double plastic bags and sent to the laboratory for analysis.
- **Also for periods without rain the empty bottles must be sent for cleaning.**

- The sampling bottle with screw cork is weighted to determine the precipitation amount.
- The funnel must regularly be sent to the laboratory for cleaning, the recommended frequency is every month. In the laboratory, the funnel is cleaned with 2% HNO₃.

Storage of equipment in the field should always be in plastic bags to prevent contamination and kept on as clean and dust-free place as possible. Especially it should be avoided to let the equipment be in contact with or close to metal surfaces as copper, zinc, aluminium etc. since these may often give off metallic dust.

The sampling procedures described above are similar for both wet-only and bulk collectors. However, when using bulk collector for snow sampling, the funnel is often full before the end of the sampling period. The station observer must therefore take the collector (both funnel and precipitation bottle) indoor whenever it is full, and close the funnel with a polyethylene lid. The lid must have been cleaned before use and it should be kept on during the entire melting process. While this sample is melting another collector and funnel is installed, and when the sampling period is finished, the samples are poured together in the last collector. Before pouring, the sample should be shaken to include possible solid residue. If the amount is too much, both collectors are sent to the laboratory. A major drawback of the bulk sampling approach is the likely reasons for contamination due to insects, bird droppings or other material in the sampling vessels. This is especially a problem for extended sampling periods. The risks of contamination are kept under control by using two or three parallel samplers. Contaminated samples can then be identified and discarded.

3.10.4 Conservation and filtering precipitation samples

3.10.4.1 Sample storage

Precipitation samples should be stored in the dark and refrigerated. A storage time up to 6 months can be acceptable providing that long time stability is checked. This includes the testing of blanks of samples stored for long time periods. However, to detect problems with contamination on an early stage, it is recommended to analyse as soon as possible after sampling.

After measuring the sampling volume by weighing the storage bottles, nitric acid should be added (this can also be added before sampling.). This can be done by adding one ml of suprapure concentrated nitric acid to each 100 ml precipitation. This will dissolve the metals that could be adsorbed to the walls of the container. The equipment used for this procedure must be carefully washed with 1% HNO₃ before use and plastic gloves must be worn. Acidified samples should be stored in the collection bottle for at least 24h before being transferred to acid cleaned storage bottles. The samples should be stored refrigerated (4°C) until analysis.

Filtering the samples should generally be avoided to prevent contamination; however it may be necessary for samples containing too much non-dissolved material, which is often the case for precipitation samples in South and Central Europe. Procedures for filtering are described in Chapter 3.10.4.2.

3.10.4.2 Filtration of precipitation

Acidify the collected precipitation in the sampling bottle as described in the section above. Equipment for vacuum filtration should be used. **All equipment used for filtration must be thoroughly cleaned in 2% HNO₃.** A cellulose acetate filter with 0.45 µm pore size (e.g. Sartorius, No. 1106-50-N) should be used. If sufficient amount of precipitation has been collected, filter about 20-50 ml of the sample to rinse the filter and discard the filtrate. Then filter 100 ml of the sample and transfer into an acid cleaned bottle for analysis. If less than 120 ml precipitation is collected, filter 20-50 ml 1% HNO₃ s.p. to rinse the filter and discard the filtrate. Then filter the collected precipitation and transfer into an acid cleaned bottle for analysis. Change filter and rinse the filtration flask with 1% HNO₃ s.p. between samples. Filtered blank samples should be prepared as a control for possible contamination during filtration.

3.10.5 Field blanks

Two extra sampling bottles are brought to the site; one containing about 100 ml diluted HNO₃ (or HCl for Hg sampling), pH 3 to 4, and one empty. After removing the regular sample bottle and washing the funnel as in the ordinary exchange procedure, the empty bottle is installed and the diluted acid is poured through the sampling device. The bottle is capped and brought to the laboratory for analysis. Field blank samples should be taken regularly, at least four times a year. If blank values exceed 20% of the concentration normally measured at the site measures should be taken to reduce the blanks (i.e. exchange or cleaning of sampling devices). The yearly average blank values are used to determine the detection limit and should be reported to CCC.

3.10.6 Measuring the influence of dry deposition

After a fixed period, i.e. one week without any rain, 100 ml diluted HNO₃ (or HCl for Hg sampling) are poured into the funnel and collected in the empty precipitation bottle. The bottled is disconnected and sent to the laboratory for analysis. The metal content will then indicate the importance of dry deposition. This type of field blank should be done regularly and especially important when a new station is installed, afterwards it should be done yearly. This exercise is especially important when considering the use of bulk collector for precipitation sampling.

3.10.7 Quality assurance

The low ambient concentration of trace elements will easily cause wrong measurements if strict precautions are not taken to prevent contamination and other sources of errors. The laboratories collecting trace element data for EMEP should therefore have a QA procedure, which is designed for their own sampling and analytical procedures. The QA procedures should among others include:

- **Field and analytical blanks.** Frequent use of field and laboratory blanks, which are important in order to discover weak part of the sampling, handling and analytical procedures. The blank results should also be used to correct the

measurements when necessary. The detection limits for the methods need to be quantified, as three times the standard deviations of blanks.

- **Chemical blanks.** The chemicals used may themselves be a contamination source for some elements and have to be checked.
- **Cleaning.** Glassware and other materials used for storage of samples may both act as a source and a sink for some transition and heavy metal ions. Consequently, it is important to clean glassware and polyethylene equipment several times with dilute solutions of nitric acid followed by deionized water.
- **Gloves.** Plastic gloves must be used whenever working with the samples and sampling equipment.
- **Analytical intercomparison and reference material.** Interlaboratory exercises have to be a part of the measurement programme in order to ensure, as far as possible, a consistent data set. Certified Reference Material (CRM) of artificial precipitation samples and solid samples are available from various organisations, e.g. BCR, NIST and IAEA. Additionally the CCC will distribute samples, both of artificial precipitation and exposed filters. Once RMs certified for elemental composition of aerosol deposition on filters becomes available, they will be preferred.
- **Field intercomparison.** Field comparisons are especially important in the starting face of the measurement program to prevent erroneous data for a long time period. For example, it is important in the choice of using either a wet-only or bulk collector. In Scandinavia it has shown that the differences are small, but the situation might be very different in other parts of Europe.

3.10.8 References

EMEP (1993) Proceedings of the First Workshop on emissions and modelling of atmospheric transport of persistent organic pollutants and heavy metals.

Durham, N. C., United States, 6-7 May 1993. Lillestrøm, Norwegian Institute for Air Research (EMEP/CCC-Report 7/93).

EMEP (1996) Proceedings of the EMEP Workshop on European monitoring, modelling and assessment of heavy metals and persistent organic pollutants.

Beckbergen, Netherlands, 3-5 May 1994. Bilthoven (RIVM Report 722401013).

EMEP (1997a) EMEP-WMO Workshop on strategies for monitoring of regional air pollution in relation to the need within EMEP, GAW and other international bodies. Aspenäs, Sweden, 2-4 June 1997. Kjeller, Norwegian Institute for Air Research (EMEP/CCC-Report 10/97).

EMEP (1997b) Report and proceedings of the workshop on the assessment of EMEP activities concerning heavy metals and persistent organic pollutants and their further development. Volume I. Moscow, Russian Federation 14-26 September 1996. Geneva (EMEP/MSC-E Report 1/97, WMO/GAW report No 117).

UN-ECE (2001) Measurements and modelling. (EB.AIR/GE.1/2001/4).
<http://www.unece.org/env/documents/2001/eb/ge1/eb.air.ge.1.2001.4.e.pdf>

NILU and IVL (1993) EMEP-long term plans, Annex 1: Measurement program for heavy metals. Lillestrøm, Norwegian Institute for Air Research (EMEP/CCC-Note 2/93).

Winkler, P. and Roider, G. (1997) HELCOM-EMEP-PARCOM-AMAP Field intercomparison of heavy metals in precipitation 1995. Berlin, Umweltbundesamt (Report 104 08 540).

WMO (1971) Guide to meteorological instrument and observing practices. Geneva (WMO No. 8 TP 3).

3.11 Sampling of heavy metals in particles

3.11.1 Introduction

The recommended sampling frequency for heavy metals in particles is weekly and is recommended to collect the PM₁₀ fraction. A cost efficient strategy may be to combine PM₁₀ measurements that also are part of EMEP's measurement program with particulate heavy metal sampling. However, since the PM₁₀ measurements are to be done on a daily frequency extracts should be combined into weekly samples to be analysed for heavy metals. Analysis on daily samples should be carried out during campaign studies. It is though important to realize that when collecting particles for heavy metal analysis it is necessary to take extra precautions to prevent contamination.

Either high- or low volume sampler may be used. The choice depends on the sampling period. For short sampling periods (daily) a high volume sampler is usually needed. With a high volume sampler it is possible to collect samples of 1600 m³ per 24 hours. Low volume samplers are in comparison in the range of 1-3 m³ per hour. The filter pack method, used for sampling of the main air components is a low volume sampler and can be used for heavy metal sampling if the sampling period is longer, i.e. weekly sampling. For clarification, many particle samplers that today are called low volume sampler have also been classified as medium volume sampler since they have been compared with the flow rate of absorption solution which has even slower rate.

Another important issue is which particle size should be sampled, fine (PM_{2.5}), coarse + fine (PM₁₀) or total particulate matter (TSP). Most of the high or low volume samplers provide the possibility to collect either total suspended particle matter or a fraction with a defined cut-off; which to prefer depends on the aim of the measurements. In order to obtain the best estimate of the deposition of heavy metals, a size distribution is preferred. However, several studies indicate that the mass distribution is different for the elements, and to obtain an informative size distribution there should be sampled 7-8 fractions. This is very expensive and for monitoring purposes it is generally sufficient to sample one fraction. Sampling of particles less than 10 µm will to a large extent contain the main fraction of long range transported heavy metals and it is recommended that this fraction is collected. A size distribution should be done at a few stations in Europe.

When collecting particles for heavy metal analysis it is necessary to take precautions to prevent contamination. All equipment used has to be cleaned carefully and gloves must be used whenever the filters are treated.

3.11.2 Sampling equipment

3.11.2.1 The air sampler

The same sampler as for PM₁₀ measurements described in 3.15 can be used.

In addition, low volume sampler for the filterpack system can be used. A general description of this sampling equipment is written in the Chapter [3.2](#) under sampling of the main components.

3.11.2.2 Filters

See general description under 3.15.3. It is strongly recommended to use either teflon or quartz filters for heavy metal sampling; however the teflon filters can not be used for high volume sampling with a prescribed flow, but may be used for low volume sampler. Glass filters do often have high blank values for certain elements. Teflon holders are recommended since they can be washed with acid before use and generally have low blank values. Quartz glass filters do have the advantage that they can be baked at 500°C prior use. Cellulose filters may be used as well; however, it must be checked whether the flow rate is maintained at given level.

All handling of filters should be made in a clean air facility (clean room or at least clean bench). Plastic gloves and acid washed utensils are necessary. All equipment should be stored in double plastic bags in a dust free environment. All parts that may be in contact with the filters should, if possible, be cleaned in nitric acid before the filters are inserted, and after exposure the filter should be stored in acid cleaned equipment.

3.11.3 Sampling procedure

In addition to the general siting criteria given in Chapter 2, it is important that the inlet is located far from any obstruction that might influence on the airflow, like building walls and trees etc. Some pumps have shown to give some dust containing copper. Air from the pump should therefore be transferred in a separate tube at least 10 metre from the filter intake.

The sampling procedures may be somewhat different from one air sampling system to another. Standard operating sampling procedures (SOP) should therefore be based on the sampler's operator manual. The procedure is also dependent on whether the filters need to be weighted for PM₁₀ measurements or not, see Chapter 1.1.

It is very important that the filters are stored within a plastic bag with zippers when it is transported between the laboratory and the field. One should also use tweezers made of not metallic material or covered with teflon when touching the filter. Never touch the filters with the fingers. After exposure the high volume filters are folded in two with the exposed side against each other, put in the plastic bag and sent to the laboratory for analysis. For low volume sampler the filter holder is sent to laboratory where it is dismounted.

Field reporting forms should always be put in a separate plastic bag in case of accidental leaks from precipitation samples, which may be contained in the same transportation box.

3.11.4 Field blanks

Field blanks should be taken regularly, at least every quarter a year. They should be handled similar as the other filters from the batch and given the same chemical treatment and analysis as the exposed filters. If blank values exceed 20% of the concentration normally measured at the site measures should be taken to reduce

the blanks (i.e. exchange or cleaning of sampling devices). The yearly average blank values are used to determine the detection limit and should be reported to CCC.

3.11.5 Extraction from filters

Filters used in high volume samplers should be cut into smaller pieces before extraction. The partition may be done by folding and cutting 1/4 or 1/8 of the filter using non-metallic tools. Another option is to use a well-defined form to cut a piece of e.g. 10% of the filter. The filter part is cut into smaller pieces and 6-7 ml of concentrated nitric acid is added to the filter in a teflon bomb. To extract particles from filters in a low volume sampler, the whole filter is included and 1.5 ml concentrated nitric acid is added to the bomb.

The bomb is kept at 150-170°C for 6-8 hours. The solution is cooled to room temperature and transferred to a 50 ml volumetric flask. If the analyses are to be performed using ICP-MS the internal standard is added to this solution and then diluted to the mark with distilled water. The solution should now contain 10% HNO₃.

3.11.6 Filter blanks

It is recommended that 5% randomly selected samples from each new batch of filters are analysed as laboratory filter blanks. The purpose of the filter blanks is to control the quality of the filters rather than to estimate the laboratory detection limit. Normally, the blank values should be sufficiently low that their values can be ignored. If high blank values are found a problem has occurred which has to be identified and solved, e.g. by using filters or chemicals from another batch, and by inspection of the routines in the laboratory.

3.11.7 Calculation of results

The flow volume is given in cubic feet per minutes (cfm) for some samplers, it should be given in cubic meter per hour.

$$1 \text{ foot}^3/\text{min} = 0.02832\text{m}^3 * 60 \text{ min/hour} = 1.698 \text{ m}^3/\text{h}.$$

When calculating airflow the average between start and stop flow is used. The total air volume in cubic meter is then given as:

$$\text{Total air volume} = \text{Average flow} * \text{total sampling time (h)}$$

The concentrations of the element in the air sample should be expressed in ng /m³; this is given by:

$$C = \frac{a \cdot v_{extr} - F_b}{v_{air}}$$

C is metal concentration in ng/m³
a is concentration of the element in ng/ml
v_{extr} is the extraction volume in ml

v_{air} is the air volume from the sampler, in cubic meter at approximately 20°C, and corrected for height from elevated sites.

F_b is average amount of metal in field blank (ng)

3.11.8 *Quality assurance*

See chapter [3.10.7](#).

3.12 Sampling of mercury in precipitation and air

3.12.1 Introduction

The availability of adequate techniques for the sampling and analysis of mercury in air and precipitation has grown during the last decade. Today, monitoring of mercury in air and precipitation is routinely done by a number of institutes throughout Europe and North America. From 1999, mercury has been part of the EMEP program; but at present, monitoring of the atmospheric content of mercury is carried out only at a minor number of EMEP stations.

Important anthropogenic sources of mercury are burning of fossil fuels, waste incineration plants and crematoriums.

Sampling of particulate phase mercury in air is one of the difficult steps in measurements of atmospheric mercury. This is mainly due to errors that may occur during both sampling and analysis. In ambient air the particulate fraction of mercury usually is less than 5%, with volatile mercury making up the remainder. This increases the risk of gas to particle conversion during sampling. For this reason, sampling and analysis of particulate phase mercury should be considered as an operationally defined method. The presence of particulate mercury in air will greatly influence the overall atmospheric deposition of mercury and further development of these techniques is highly desirable, and is needed before any recommended procedure can be given.

We are very grateful to OSPARCOM and John Munthe at IVL to allow us to use their guidelines on sampling and analysis of mercury. The text is with minor changes taken from their report (Munthe, 1996; OSPAR, 1997).

3.12.2 Sampling methods for mercury in precipitation

3.12.2.1 Sampler design and materials

Mercury is collected in special precipitation samplers. Two alternative materials may be used for funnels and collection bottles: borosilicate glass and a halocarbon such as Teflon or PFA. Borosilicate glass is often preferred due to lower costs and general availability. Quartz glass may also be used but is generally avoided due to high costs.

Precipitation can be sampled using either wide-mouthed jars or funnels and bottles. The sampling vessels can be bulk samplers which are open at all times or wet-only samplers which are open only during precipitation events. For monitoring purposes, bulk sampling using funnels and bottles is normally adequate (Iverfeldt, 1991a,b; Jensen and Iverfeldt, 1994). Wet-only samplers are used by the German national monitoring programme as well as by research groups working in the Great Lakes area (Landis and Keeler, 1996) and in the US National Atmospheric Deposition Programme (Vermette et al., 1995). Wet-only samplers have the advantage that they avoid particle dry deposition, although the contribution of gaseous or particulate mercury species to the wet deposition fluxes in non-industrialised or non-urban areas is probably not large (Iverfeldt and Sjöberg, 1992; Iverfeldt and Munthe, 1993).

For extended sampling periods it is necessary to prevent the diffusion of Hg^0 into the precipitation sample collected, since it could contribute to the mercury content of the sample via oxidation to water-soluble forms. This can be done easily by using a capillary tube between the funnel and the bottle. It is also necessary to shield the sample bottles from light to avoid photo-induced reduction of the mercury in the precipitation sample.

Samplers should be designed for sampling during all seasons and all climatic conditions. Thus a heating device should be included for melting snow and to prevent the formation of ice in the funnel and bottles during winter and, depending on climatic conditions, it may be useful to cool the samples in locations where high temperatures are expected during summer. Funnel area and bottle sizes should be modified to suit the sampling period used.

The bulk sampler design used in the Swedish national monitoring program for mercury is shown in Figure 3.13.1.

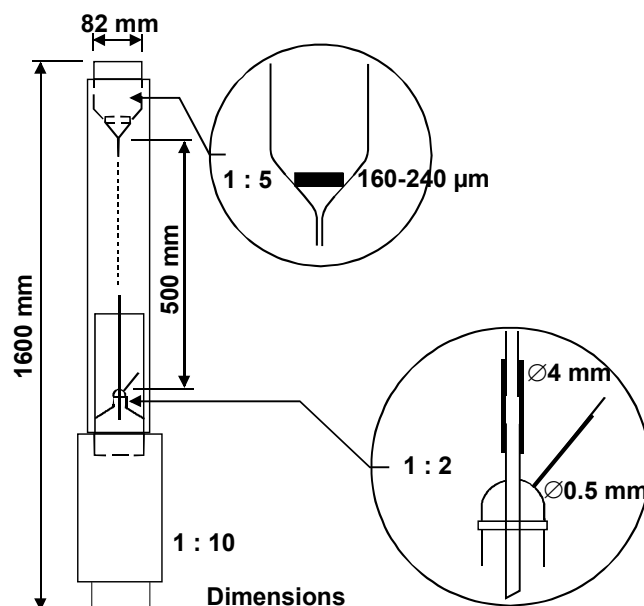

Figure 3.4: Schematic of bulk sampler for sampling of precipitation for mercury analysis from IVL-Gothenburg.

In the air pollution network of the German Federal Environmental Agency (Umweltbundesamt) a commercially available automatic (wet-only) precipitation collector (type: ARS 721) is used for mercury (Bieber, 1995). The funnel of this sampler is made of borosilicate glass while the collection bottle is made of halocarbon polymer (PFA) and has a heating system with a thermostat.

3.12.2.2 Washing procedure for glass equipment

All glass equipment used for sampling or for storing water samples for mercury analysis must be cleaned extensively before use. The glassware is washed extensively according to the following procedure.

Plastic gloves should be used during all steps of the washing procedure. Glassware that is not being leached in tanks should always be stored in double plastic bags.

1. Leach in an alkaline detergent for 24 hours. Rinse thoroughly with de-ionised water.
2. Leach in a solution of HNO₃ (Puriss): de-ionised water (1:3) for 7 days. This should be done in a polyethylene tank placed under a fume hood. Rinse thoroughly with de-ionised water.
3. Leach in a 0,1 M solution of HNO₃ (P.A.) in high-purity water (e.g. Milli-Q) for 7 days. Rinse thoroughly with de-ionised water.
4. Fill bottles with high purity water. Add 5 ml/l BrCl solution. Leave to stand for at least 24 hours.
5. Add 5 ml/l 12% NH₂OH·HCl. Leave to stand for 1 hour.
6. Pour out the above solution. Rinse with large amounts of de-ionised water followed by large amounts of high-purity water.
7. Add 2,5 ml 30% HCl (Suprapur) to the bulk sampler bottles (0,5 l borosilicate glass) All other bottles and containers should be filled with 5 ml/l 30% HCl (Suprapur). Other glassware should be air-dried in a clean zone.

Bottles that are believed to be contaminated are baked at 500°C for 5 hours and then washed according to the procedure above, but excluding step 1.

This procedure is generally sufficient for containers used for the sampling and analysis of precipitation. After analysing samples with extremely low concentrations of mercury the BrCl treatment steps according to steps 4-6 above is generally sufficient.

3.12.2.3 Sampling procedure

All samples and replacement sample bottles should be handled with care in order to avoid contamination during transport and storage. Sample bottles should only be handled using plastic gloves and all bottles should be kept in double plastic bags during transport and storage.

Before sending the precipitation bottle to the field they should be filled with 5 ml/L concentrated HCl. One should therefore be extra careful when handling these bottles.

The following procedure is recommended for bulk samplers of the design seen in Figure 3.13.1. For alternative sampling devices, this procedure can be adapted.

1. Bring a new collection bottle, plastic bags and container (squeeze bottle) with high purity water to the sampler. All equipment needed for the bottle exchange should be placed on a plastic cover either on the ground or available surface.
2. Remove outer plastic tube

3. Open double bags of the new collection bottle (but leave the bottle in the bags).
4. Carefully remove the ground glass joint connecting the bottle to the capillary. Use both hands, one for loosening the glass fitting the other for holding the funnel.
5. Remove the stopper from the new collection bottle and close the bottle containing the precipitation sample. This bottle is then put in double plastic bags.
6. Without mounting the new bottle, rinse the funnel and capillary with high purity water. If visible materials (dust, insect etc.) are present, disconnect the funnel from the capillary and rinse separately. New plastic gloves should be used if handling the watch glass or touching the inside of the funnel is necessary. If the funnel and capillary are visibly dirty even after rinsing, they must be exchanged with newly washed pieces.
7. Remove the new collection bottle from the plastic bags and place in the plastic casing. Connect the ground glass fitting and check all connections. Make sure that all connections are without gaps where the silicon tubing is exposed to the precipitation sample unnecessarily.
8. Replace outer plastic tube.

Samples for storage must be refrigerated and kept in the dark. They may be stored up to 6 months provided that the long-term stability is checked. This includes the testing of sample blanks stored for corresponding periods.

A critical step when evaluating wet deposition of mercury is the availability of correct data on precipitation amounts. Different sampler designs have different precipitation sampling efficiencies and this may lead to incomparable results when calculating the wet deposition of mercury, even if the analysis are harmonised. For all techniques, a parallel measurement of precipitation amounts should be made in order to identify discrepancies. A standard rain gauge should be used in parallel with the sampling equipment for mercury and the WMO recommendations should be followed. If systematic errors are found, the sampler design should be reconsidered.

3.12.2.4 Quality control – Quality assurance

Written instructions for personnel carrying out the sampling are necessary to avoid contamination. All routine handling of samples and sampling equipment should take place according to specified procedures. Furthermore, replacement parts should be easily available so that glassware can be exchanged if contamination is suspected.

The risks of contamination when using bulk samplers and extended sampling times are controlled by using two or three samplers in parallel. Contaminated samples can then be identified and discarded and the corresponding data excluded.

3.12.2.5 Field blanks

Field blanks should be taken at least four times each year.

Two extra sampling bottles should be brought to the site; one containing dilute HCl (pH 3 to 4) and one empty. After removing the regular sample bottle the empty bottle should be installed and the dilute HCl poured through the sampling device (e.g. funnel and capillary). The bottle should be stoppered, double bagged and brought to the laboratory for analysis. The mercury content of the dilute HCl should be compared to that of samples stored in a clean laboratory environment. If the blank values exceed 20% of the concentrations normally measured at the site, measures should be taken to reduce the blanks (for example, by exchanging or by cleaning the sampling devices).

The yearly average blank value is used to determine the detection limit and should be reported to CCC.

3.12.2.6 *Special problems*

When first starting to sample precipitation for mercury analysis numerous problems can arise, mostly associated with high blanks. Weekly sampling should be undertaken initially, even if monthly sampling is planned. In this way the number of sampling periods without results can be reduced.

The most common causes of sample contamination are insects, bird droppings or other material in the sampling vessels. This is the major drawback to bulk sampling. In areas with large numbers of birds in the vicinity, it may be necessary to install devices preventing birds from perching on the samplers.

Using two or three samplers in parallel controls the risks of contamination when using extended sampling periods. Contaminated samples can then be identified and the results discarded thus minimising the loss of information. Contamination of two samplers in parallel is very rare.

When temperatures are high, it may be necessary to cool the sample bottle to prevent the evaporation of mercury from the sample.

3.12.2.7 *Summary*

	Recommendation	Acceptable alternative
Material	Borosilicate glass.	Halocarbon materials, quartz.
Sampler design	Bulk samplers or wet-only samplers with gaseous Hg prevention and light shield. Heating and/or cooling of sample bottle depending on climatic conditions.	Event sampling using funnels and bottles or jars.
Sampling time	1 week to 1 month.	
Preservation of samples	Monthly sampling 5 ml/l HCl (Suprapur) prior to sampling.	Adding 10 ml/l HCl after sampling in sampling periods of <2 weeks and samples are cooled if necessary.
QA/QC	Field blanks. Written instructions for field personnel.	

3.12.3 Sampling methods for total gaseous mercury in air

3.12.3.1 Sampler design and cleaning procedure

The sampling of total gaseous mercury (TGM) in air is usually done using gold traps with gasometers or mass flow controllers for air volume measurements. During the last few years, automated instruments for the sampling and analysis of mercury in air have been made available. The automated method applies the same basic principles as the manual method and has been shown to generate comparable results (Schroeder et al., 1995; Ebinghaus et al., 1999).

Gold traps comprise 10-12 cm quartz glass tubes filled with gold adsorbent. The gold adsorbent can either be small pieces (1-2 mm) of 1 mm solid gold wire mixed with a crushed-quartz glass bearer or, alternatively, sand, glass beads or quartz glass coated with a thin layer of gold. The latter trap type usually generates lower blank values.

The gaseous mercury collected with the gold trap in the field is transferred by heating to a calibrated Au trap, using Hg-free argon with a purity of >99.998% (at a flow rate of 30 ml/min) as the carrier gas. This is known as the dual amalgamation technique. The sampling and transfer lines are made of Teflon tubing. Glass to glass connections (i.e. between the sampling trap and the analytical trap) are made with silicone tubing. The inlet filter is a quartz tube 75 mm in length (with an inner diameter of 4 mm and an outer diameter of 6 mm) with a quartzwool plug 15 mm in length. A brief summary of the equipment and cleaning procedure is as follows:

- material: glass, quartz, Teflon
- heating device: e.g. Perkin Elmer Part No. 102961 with a variable transformer
- cleaning procedure for the field trap: thermal desorption at 500°C for three minutes while purging with a Hg-free argon stream at a flow rate of 30 ml/min (three consecutive times)
- cleaning procedure for the analytical trap: thermal desorption at 800°C for 25 seconds while purging with a Hg-free argon stream at a flow rate of 30 ml/min (two consecutive times)
- cleaning procedure for the inlet filter: thermal desorption at 1200°C for 1.5 minutes while purging with an air-stream of 30 ml/min (three consecutive times)
- argon: > 99.998 Vol.% (Producer: e.g. Messer Griesheim)
- pump: automatic Dräger gas detector pump ("Quantimeter 1000"). One stroke volume = $100 \pm 5 \text{ cm}^3$.

3.12.3.2 Sampling procedure

The sampling of total gaseous mercury in air is relatively straightforward and without major difficulties. The site should be chosen with great care to avoid

contamination or non-representative results. Sampling should be performed >1.5 m above the ground or other surfaces (walls *etc.*) in order to avoid the influence of local fluxes. The sampling system contains 1 protective quartz wool plug followed by 2 gold traps in series.

The analytical method for sampling total gaseous mercury (including elemental, organic and inorganic mercury) is based on the amalgamation of mercury with gold. Total gaseous mercury is collected on the surface of the gold. For sample collection two of these traps are placed in series. With this arrangement a breakthrough of mercury is detected with a significant mercury amount on the second trap.

The sampling time and air volumes should be sufficient to collect enough mercury for analysis but not so large as to cause a breakthrough of mercury. Sampling flow rates in the range 0,1-0,5 l/min up to a maximum volume of 100-1000 litres is normally adequate.

The general configuration for the set-up of the sampling system for total gaseous mercury in air:

- One quartz wool plug followed by two field traps in series
- sampling flow: 0,100-0,500 ml/min
- sampling time: 12-24 hours (for TGM concentration in the range of 1-10 ng/m³)

3.12.3.3 Sample storage

Field traps should be exchanged according to a fixed procedure taking great care to avoid contamination. Before and after sampling the ends of the traps are closed with plastic caps and the traps are stored in a firmly closed glass bottle. To prevent contamination during storage 1 g of silver wool should be kept in the bottle to bind gaseous mercury diffusing into the storage vessel.

3.12.3.4 Volume standardisation

To convert the sample volume to a volume with standard conditions (0°C and 1 atm or 273.16°K and 1013.25 mB) it is necessary to multiply the pump volume with correction factors (calculated from the Ideal Gas Law).

$$V (\text{Std.}) = V (\text{current}) * 273.16 \text{ K/T (inlet)} \text{ and } V (\text{Std.}) = V (\text{current}) * P (\text{inlet}) / 1013.25 \text{ mB.}$$

3.12.3.5 Quality control - Quality assurance

The necessary quality control steps are primarily associated with gold trap collection and analytical instrument reliability. All gold traps must be individually calibrated at regular intervals. This is most conveniently done using a source of gaseous mercury, *i.e.* a thermostated vessel containing liquid mercury from which gaseous samples can be drawn with a gas tight syringe. Gold traps with low recovery must be discarded.

Alternative methods for sampling mercury in air are not generally available. Commercially available iodated carbon traps have, however, been successfully used for sampling over extended periods, *i.e.* days (Bloom *et al.*, 1995).

3.12.3.6 *Special problems*

Under certain conditions, breakthrough of mercury can occur at air volumes considerably smaller than those recommended above. This is usually due to the presence of trace constituents in the air which block the gold surface. Possible contaminants are sulphur-containing volatile organic compounds and volatile inorganic species capable of forming solid salts on the gold surface via atmospheric reactions (*e.g.* $(\text{NH}_4)_2\text{SO}_4$). If this happens, considerably smaller sampling volumes should be used, *i.e.* <100 litres.

When using automated systems frequent re-calibration is necessary and this frequency will vary according to the temporal resolution of the sampling. Daily re-calibration is a minimum.

3.12.3.7 *Summary*

	Recommendation	Acceptable alternative
Material	Solid gold traps.	Coated gold traps.
Sampling design	1 protective quartz wool plug followed by 2 gold traps in series.	Teflon filter or quartz fibre filter followed by 2 gold traps in series.
Air flow rate	200 to 500 ml/min.	
Sample volume	100 to 800 litres.	
QA/QC	2 gold traps in series to check mercury breakthrough.	

3.12.4 *Intercomparisons*

Within any monitoring network where data are reported from different institutes, regular intercomparisons are necessary. The intercomparisons should be performed for all steps in the measurement procedure. The recently completed intercomparisons on the sampling and analysis of heavy metals organised by Umweltbundesamt in Germany together with EMEP/CCC, HELCOM, PARCOM and AMAP, is a good example of a successfully managed exercise with encouraging results (Winkler and Roeder, 1997).

In 1991 an intercomparison exercise for mercury deposition was held at Rörvik, Sweden (Iverfeldt and Sjöberg, 1992). The conclusions from that exercise was that the measured fluxes varied within a factor of 2 to 4 which was explained as systematic errors in the methods used by several of the participants. More encouraging results were found in the Mace Head intercomparison in 1995 (Ebinghaus *et al.*, 1999) where relatively good agreement between different methods for measurements of mercury in air and precipitation were obtained.

3.12.5 Commercial supply

The equipment list below shows examples of known good samplers. However there might be several others excellent products on the market, but if used they must anyhow also have been proven to give comparable and reliable results.

Sampler	Name	Manufacture	Materials
Wet only	MDN 1 sampler modified Aerochem Mmetric sampler used in US-NADP		Double system: glass funnel, glass capillary and bottle for Hg sampling the other PE or Teflon funnel and bottle for trace metals
	ARS 721	Eigenbrodt http://www.eigenbrodt.de/	Borosilicate glass funnel, PFA bottle, heating
Bulk	NSA 181 KD	Eigenbrodt http://www.eigenbrodt.de/	Quartz glass funnel, teflon tube teflon bottles, heating and cooling
	IVL and WDNR – modified IVL	IVL, P.O.Box 47086 S-402 58 Gothenburg Sweden http://www.ivl.se/	Borosilicate glass funnel, glass filter, capillary tube and glass bottle, heating in the modified version
	GKSS	International bureau of GKSS, Germany http://www.gkss.de/	Teflon funnel, brown glass bottle
Hg(g) sampler	Gold traps	Brooks Rand, US http://www.brooksrand.com/	
Hg-monitor For Hg (g)	Tekran 2537A	Tekran Inc, Toronto, Canada http://www.tekran.com/	Automatic, 5 min time resolution
Automated water Analysis systems	P.S. Analytical	P.S. Analytical, Kent, UK, http://www.psanalytical.com	
	Perkin Elmer	http://instruments.perkinelmer.com/index.asp	
	Tekran 2600	Tekran Inc, Toronto, Canada http://www.tekran.com/	
Detectors	P.S. Analytical	P.S. Analytical, Kent, UK, http://www.psanalytical.com	CV-AFS
	Tekran 2500	Tekran Inc, Toronto, Canada http://www.tekran.com/	CV-AFS

3.12.6 References

Bieber, E. and Althoff, S. (1995) Methods for sampling and analysis of total mercury in precipitation in the air pollution network of the German Federal Environment Agency (Umweltbundesamt). In: *JAMP Guidelines for the sampling and analysis of mercury in air and precipitation*. London, OSPAR (Technical Annex 2, 20-23).

Bloom, N.S., Prestbo, E.M., Hall, B. and Von der Geest, E.J. (1995) Determination of atmospheric mercury by collection on iodated carbon, acid digestion and CVAFS detection. *Water, Air, Soil Pollut.* 80, 1315-1318.

- Ebinghaus, R., Jennings, S.G., Schroeder, W.H., Berg, T., Donaghy, T., Ferrara, R., Guentzel, J., Kenny, D., Kock, H.H., Kvietskus, K., Landing, W., Mazzolai, B., Mühleck, Munthe, J., Prestbo, E.M., Schneeberger, D. Slemr, F., Sommar, J., Urba, A. Wallschläger, D. and Xiao, Z. (1999) International field intercomparison measurements of atmospheric mercury species at Mace Head, Ireland. *Atmos. Environ.*, 33, 3063-3073.
- Fitzgerald, W.F. and Gill, G.A. (1979) Subnanogram determination of mercury by two-stage gold amalgamation and gas-phase detection applied to atmospheric analysis. *Anal. Chem.*, 51, 1714-1720.
- Iverfeldt, Å. (1991a) Occurrence and turnover of atmospheric mercury over the Nordic countries. *Water, Air, Soil Pollut.*, 56, 251-265.
- Iverfeldt, Å. (1991b) Mercury in canopy throughfall water and its relation to atmospheric deposition. *Water, Air, Soil Pollut.*, 56, 553-542.
- Iverfeldt, Å. and Munthe, J. (1993) In: *Proceedings from the EPA/A&WMA symposium measurement of toxic and related air pollutants*, Durham, NC.
- Iverfeldt, Å. and Sjöberg, K. (1992) Intercomparison of methods for the determination of mercury deposition to convention waters. Göteborg, Swedish Environmental Research Institute (IVL Report B 1082).
- Jensen, A. and Iverfeldt, Å. (1994) Atmospheric bulk deposition of mercury to the southern Baltic sea area. In: *Mercury pollution – Integration and Synthesis*. Watras, C.J., Huckabee, J.W. (Editors), Boca Raton, Lewis Publ., pp. 221-229.
- Landis, M.S. and Keeler, G.J. (1996) A critical evaluation of a wet only precipitation collector designed for network operation for mercury and trace elements. Presented at the Fourth International Conference on mercury as a global pollutant, Hamburg.
- Munthe, J. (1996) Guidelines for the sampling and analysis of mercury in air and precipitation. Gothenburg (IVL-report L 96/204).
- OSPAR (1997) JAMP Guidelines for the sampling and analysis of mercury in air and precipitation. London.
- Schroeder, W.H., Keeler, G., Kock, H., Roussel, P., Schneeberger, D. and Schaedlion, F. (1995) International field intercomparison of atmospheric mercury measurement methods. *Water, Air Soil Pollut.*, 80, 611-620.
- Vermette, S., Lindberg, S. and Bloom, N. (1995) Field tests for a regional mercury deposition network - sampling design and preliminary test results. *Atmos. Environ.*, 29, 1247-1251.
- Winkler, P. and Roeder G. (1997) HELCOM-EMEP-PARCOM-AMAP field intercomparison of methods for the determination of heavy metals in precipitation 1995. Berlin, Umweltbundesamt (Report 104 08 540).

3.13 Sampling of persistent organic pollutants pesticides and PCBs

3.13.1 Principle

This method covers the following groups of components:

Chlororganic pesticides:

- α -, β -, and γ -HCH
- HCB
- Chlordanes (including acid labile components)
- DDTs
- The Dieldrin group
- Trifluraline
- α -Endosulphane

Polychlorinated biphenyls,

- PCB

These components may be determined in air samples. The air samples can be collected with an air sampler with a particle filter followed by two PUF plugs. Filter and PUF plugs are extracted separately with a hexane/diethylether 9:1 mixture in a soxhlet extractor.

The extracts are concentrated and then cleaned by using adsorption chromatography (silica). After the concentration to the appropriate volume and addition of the recovery standard the components are separated and quantified by using gas chromatography combined with mass spectrometry (MS), see the chemical analysis chapter 4. 1x

3.13.2 Equipment for air sampling

Materials and equipment of similar or better performance or quality from other manufacturers may be used.

- Aluminium foil
- Glass fibre filter type A/E 142 mm diameter, Gelman no. 61635. Cleaning, see section 2.6.2
- Disposable gloves of polyethylene
- Tweezers
- Zip shut plastic bags
- Polyurethane foam plugs (PUF plugs), 11 cm x 5 cm (diam. X h.), density 25 kg/m³, (Ekornes industries). Cleaning see section 2.6.2.
- PUF air sampler

NILU PUF (polyurethane foam) sampler consists of a glass cylinder (10 cm i.d.) supplied with a filter holder in one end. The other end is connected to a Siemens ELMO vacuum pump 2BH5 via an adapter and tube. The PUF sampling unit is outlined in Figure 3.13.1.

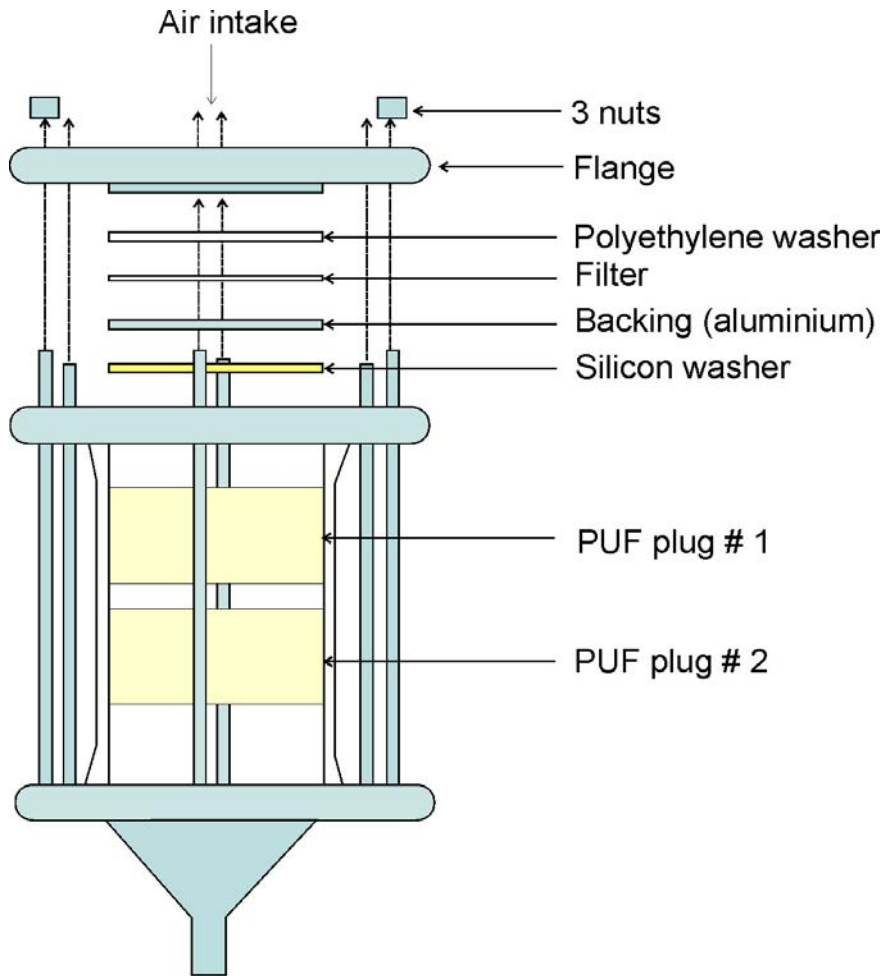

Figure 3.13.1: The PUF sampling unit.

3.13.3 Sampling procedure

Inserting unexposed filter and PUF plugs and starting sampling:

- Put on a pair of disposable gloves.
- Insert PUF plug # 2.
- Insert PUF plug # 1. Make certain that the plugs are not bent and have an even and smooth contact with the glass walls of the sampling unit.
- Insert the silicon washer.
- Mount the backing using a pair of tweezers.
- Insert the filter using a pair of tweezers.
- Insert the polyethylene washer.
- Mount the flange and tighten the three nuts.
- Start the pump.
- Adjust the airflow with the false air valve until the correct flow is obtained. Please note; the airflow decreases considerably during the first half hour (approximately) until the pump's working temperature is reached and stable conditions obtained. The airflow should then be increased until the correct flow again is reached.
- Record date, time, flow, and underpressure in the instrument logbook.

Stopping sampling and removing exposed filter and PUF plugs:

- Record date, time, flow, and underpressure in the instrument logbook.
- Stop the pump
- Loosen the three nuts and remove the flange.
- Remove the polyethylene washer using tweezers.
- Remove the filter. Fold the exposed filter over itself, exposed side against exposed side, wrap the filter in aluminium foil.
- Remove the backing with tweezers.
- Remove the silicon washer.
- Put on a pair of disposable gloves, remove PUF plug # 1 and wrap it in aluminium foil. Mark the foil “# 1”.
- Remove plug # 2 the same way and mark the aluminium foil ”# 2”.
- Filter and PUF plugs are placed in a plastic bag with zipper.

Please note: All handling of PUF plugs must be with disposable gloves. Exposed plugs and filters must be put in a freezer once the sampling is finished.

3.13.4 Weighing filters

If the weight of particles on the filter is to be determined, the filter must be weighed before and after sampling.

In this case the filter should be conditioned for 24 hours in a room where temperature and humidity are kept constant before sampling. The filter should be unwrapped from its aluminium foil, which can be used as a bed during weighing. The filter should be wrapped in the same foil after the weighing. When volatile substances such as HCH and HCB are measured, the filter must be weighed after a well-defined period, i.e. ½ to 1 hour in the conditioned room.

3.13.5 Extracting samples

After exposure the glass fibre filter containing the particle fraction of the sample is transferred to a 100 ml soxhlet extractor with 250-300 ml 10% diethyl ether/hexane mixture and an internal standard. The filter is extracted for 6-8 hours.

The PUF plugs are put into a 250 ml soxhlet extractor. This extractor should be mounted on the flask containing the particle extract and extracted for another 6-8 hours.

The filter and the PUF plugs may also be extracted independently in order to quantify the distribution between gas and particle phase. In this case the internal standard should be added to both extractors.

Na₂SO₄ is added to the extract in order to remove water before further treatment of the samples. When samples are considered to be “wet”, they should be extracted for 3 hours with acetone, followed by an extraction with diethyl ether/hexane. These extracts should be combined, dried with Na₂SO₄, and the volume reduced to 0.5 ml. The amount internal standard to be added depends on the concentration expected in the sample.

Keeper, 20 µl nonane should be added to the extract before evaporation to 0.5 ml with a TurboVap 500. Use “A” or “B” speed and 35°C water temperature. The sample is now ready for clean-up as described in the next section.

3.13.6 Cleaning of equipment

3.13.6.1 Cleaning of the sampler

The sampler is disassembled and glass, metal parts and gaskets are washed using lab detergent (RBS 25) diluted with warm water. The parts, except the gaskets, rinsed well with warm water, thereafter with distilled water and finally with acetone. The gaskets are rinsed well with warm water and distilled water, ***not with acetone.***

3.13.6.2 Cleaning of PUF-plugs

8 new plugs are put in a 2000 ml soxhlet extractor and extracted with toluene (24 h), acetone (8 h) and with toluene (8 h). Plugs, which have been previously extracted after sampling, are cleaned using soxhlet extraction with acetone (8 h) and toluene (8 h). After extraction the bulk of the solvent is removed by squeezing the plugs using solvent resistant lab gloves. The plugs are put in a desiccator placed in an oven and dried at 60°C under vacuum (100–200 mbar). Following drying the plugs are wrapped individually in aluminium foil. Pairs of plugs are stored in a zip-shut plastic bag together with a glass fibre filter (see below). Storage time should not exceed 6 months. Expiry date is written on a label on the plastic bag and batch number is written in a logbook kept in the cleaning laboratory. A sampling form is put in each plastic bag.

Toluene used in the third cleaning step for cleaning new plugs may be used later in the first cleaning step in order to reduce solvent consumption.

Glass fibre filters are heated in an oven to 450 °C (8 h). After cooling they are wrapped individually in aluminium foil. Storage time should not exceed 6 months.

3.13.6.3 Cleaning of glass equipment

All glass equipment used for sampling and/or analysis of air, water, deposition, sediment and biological samples must be colour coded in order to separate it from equipment used for samples containing high levels. After use the glass equipment is put in a 2.5% (v/v) water dilution of the lab detergent RBS (16 h). Thereafter it is rinsed 10 times with warm tap water and twice with de-ionised water. Finally the equipment is dried and cleaned in an oven at 450°C (6 h). All glass equipment is rinsed with n-hexane before it is used.

3.13.6.4 Cleaning of other equipment

Tweezers used for handling filters and PUF plugs are rinsed well with n-hexane.

3.14 Sampling of polycyclic aromatic hydrocarbons (PAH) in air

3.14.1 Principle

Sampling is performed using a high volume sampler. Particle bound polycyclic aromatic hydrocarbons (PAHs) are collected on a glass fibre filter, and more volatile PAHs are adsorbed to plugs of polyurethane foam (PUF) placed behind the filter. The filter and the plugs are Soxhlet extracted with cyclohexane after sampling. The pre-concentrated extracts are cleaned using liquid/liquid extraction and HPLC before analysis using high-resolution gas chromatography combined with mass spectrometry (GC/MS).

3.14.2 Sampling equipment and instruments

Sampler: NILU's PUF-High-volume sampler (see [3.13.2](#))

Pump: Siemens ELMO-vacuum pump 2BH5

Glass fibre filter: Type A/E, 142 mm, Gelman no. 61635 (cleaned)

PUF-plugs: 11 x 5 cm (diam. x h), density 25 kg/m³, white type (cleaned)

PUF may be replaced with XAD-2.

Aluminium foil

Plastic gloves

Tweezers

XAD-2, polystyrene divinylbenzene co-polymer, 0.3-0.85 mm particle size

Similar or better qualities from other manufacturers may be used. For sampling also Sierra, Anderson or similar high volume samplers may be used.

3.14.3 Cleaning of equipment

3.14.3.1 Glass equipment

All glass equipment must be decontaminated before use. Leave the equipment in 2.5% RBS in water for 16 hours. Flush well with hot tap water followed by MilliQ water. Leave to dry on a clean surface.

3.14.3.2 Glass fibre filter

Put ca 50 filters (Gelman-Type A/E, 142 mm) on an Al-foil and heat to 450°C for 8 hours. After cooling to room temperature wrap each filter in Al-foil.

3.14.3.3 Extraction timbles

Extract timbles for 8 hours ("1 day") with cyclohexane in a 600 ml Soxhlet extractor. Dry in a desiccator connected to a vacuum pump (capacity 2.4 m³/h, and 80 kPa (0.8 bar) at 100°C. Connect pump outlet to a cooler to condense solvent. Wrap dry timbles in Al-foil.

3.14.3.4 Sampler

Dismantle the sampler. Wash glass, metal parts and gaskets with warm detergent (2.5% RBS 25 in water). Flush all parts except the gaskets, with warm water, distilled water and acetone. Flush the gaskets with warm water, distilled water, **not acetone**.

3.14.3.5 PUF-plugs

Toluene

Clean new PUF-plugs with toluene (Merck no. 8389) in a 2000 ml soxhlet extractor. The extractor can take up to 8 plugs simultaneously. Use a 3000 ml round bottomed flask and fill toluene into the extractor until it empties the content into the round bottomed flask. Add ca. 500 ml toluene and mount the lid and cooler. Turn on the heater and the **cooling water**. Extract the plugs for 24 hours.

Acetone, cyclohexane

Squeeze toluene out of the plugs (solvent resistant gloves!) and transfer the plugs to another 2000 ml soxhlet extractor. Acetone is added as prescribed for toluene and the plugs are extracted for 8 hours.

Finally, extract with cyclohexane (new extractor) for 8 hours.

Observe! Used plugs (which previously have passed through the whole cleaning procedure, toluene included) can be cleaned as follows:

- 1) Soxhlet extraction with acetone for 8 h
- 2) Soxhlet extraction with cyclohexane for 8 h

Drying

After final extraction squeeze the cyclohexane out of the plugs. Place the plugs in a desiccator. Put the desiccator in an oven at 60°C, and connect desiccator to a vacuum pump. Dry for 16 hrs and wrap the plugs in Al-foil individually. Store pairs of plugs and a filter in zip-shut plastic bags.

3.14.3.6 XAD-2

Fill XAD-2 in a tumbler and put it in a soxhlet extractor. Extract for 8 h with each of the following solvents: Methanol, acetonitrile and diethyl ether. Leave the wet adsorbent on an Al-foil in a fume hood until it appears dry. Dry in an oven at 35°C overnight.

3.14.4 Sampling

NILU's high volume sampler consists of a glass cylinder (10 cm diam.) with a filter holder at one end. The other end is connected to a Siemens vacuum pump with a hose. Before starting sampling it is important that the plugs fit firmly to the glass wall without forming channels

See chapter [3.13.3](#) for the sampling procedure using the NILU PUF sampler.

All new samples are stored in a freezer until extraction.

For the most volatile PAHs, especially the bicyclic compounds, "break-through" will occur at high air temperature and/or long sampling time. At sampling times longer than 6 h and temperature 20 °C (or higher) a break-through will normally occur for the bicyclic PAHs, and these should not be reported with accreditation.

For sampling XAD-2 may be used instead of PUF.

3.14.5 Weighing filters

If the amount of particles in the sample is to be determined, the filter must be weighed before and after sampling. Condition the filter for 24 h at constant temperature and humidity before weighing.

3.14.6 Extraction

Fold the filter over twice and cut the rim with a scissors cleaned with cyclohexane. Transfer the filter to a timple (28 x 80 mm), in a 60 ml soxhlet extractor. Add internal standard directly to the filter using a 10, 20, 50 µl or 100 µl syringe or micropipette. Use 100 ml cyclohexane in a 250 ml round bottomed flask for the filter extraction.

Transfer the two PUF plugs to a 500 ml extractor, add internal standard, extract with 500 ml cyclohexane and use a 1000 ml round bottomed flask. Extract filter and plugs for 8 h (1 day).

If only the total PAH content in the sample is wanted, the whole amount of internal standard is added to the filter. Use 500 ml cyclohexane and a 1000 ml round bottomed flask for the extraction. After the filter extraction, remove the 60 ml extractor and replace with a 500 ml extractor containing the plugs. Continue the extraction without further addition of internal standard.

After the extraction, transfer the solvent in the extractor to the flask.

If the filter and plugs are to be analysed separately, the extracts must be cleaned separately. The extract is pre-concentrated before clean-up.

Extraction of XAD-2 is done using cyclohexane in a soxhlet extractor for 8 h. XAD-2 is transferred to a timple of suitable size and internal standard is added before the extraction is started.

3.14.7 Pre-concentration

Pre-concentration is normally performed using a TurboVap pre-concentration system. This system has an automatic stop at a final sample volume of 0.5 ml. Manual control must be made to stop the pre-concentration at 4 ml.

3.15 Measurement of PM₁₀ particles

3.15.1 Introduction

The Interlaken workshop in 1999 (EMEP, 2000) made a series of recommendations for measurements of particulate matter, and the first TFMM meeting in Vienna October 2000 built further on these conclusions and recommended a measurement program. This first TFMM meeting stressed the need for PM₁₀ measurements with a view to the current legislation in the European Union. The manual was adopted at the third TFMM meeting in Geneva 2002.

More measurement data within EMEP for assessment of the long-range transported part of the aerosol particulate mass in Europe are needed. This includes measurement of particulate mass, preferably determined according to EN 12341 (CEN, 1998), the reference method defined in EU Directive 1999/30/EC. In addition chemical characterisation and speciation of the particulate material is also highly desirable. Methods that give the added advantage of determining the chemical components in the sample are therefore recommended. The sampling period should be 24 hours and the samples should be changed daily together with the other sampling devices.

3.15.2 Sampling equipment

Different methods for the determination of aerosol particle mass have been extensively tested and compared (WHO, 1999; Guidance Document, 2001). Since different methods may give rise to systematic differences in the results, standardisation is necessary as specified by the European Union and the European Standards Organisation

EN 12341 specifies three reference methods for determination of PM₁₀. Two of these, the high- and low-volume samplers, may be used at EMEP sites to obtain daily samples for weighing and subsequent chemical analyses. EN 12341 also gives detailed instructions with respect to comparisons, which are required to show that alternative samplers are equivalent to the reference methods for determination of PM₁₀. These requirements are particularly relevant at sites where suspended dust and coarse particles form a major part of the airborne particulate matter. At many EMEP sites, however, particles < 2.5 µm may account for a large part of the total aerosol mass.

Direct recording instruments can be used if they have been shown to provide consistent results compared with gravimetric methods. They should be compared according to the CEN standard, preferably at the EMEP site and during all seasons and then used with possibly a correction factor. There are also instruments providing both gravimetric and online data measurements, which may be used if proven to give equivalent result to the standard. Monitoring with heated filters and/or inlets have a negative bias due to removal of water contained in the aerosol particles as well as evaporation of ammonium nitrate and semi-volatile organic compounds causing significant weight loss depending on season and location. It is difficult to avoid this problem even for standard gravimetric instruments where also losses of e.g. ammonium nitrate and semi-volatile organic

compounds may occur during sampling and when filters are conditioned at constant RH and temperature. But to minimize evaporation artefacts it is recommended to use monitoring instruments with unheated inlets and/or filters.

One example of instrument, which is in accordance with CEN standard (1998) for PM₁₀ measurements, is the high volume sampler Sierra-Andersen/GMW model 1200 seen in Figure 3.15.1.

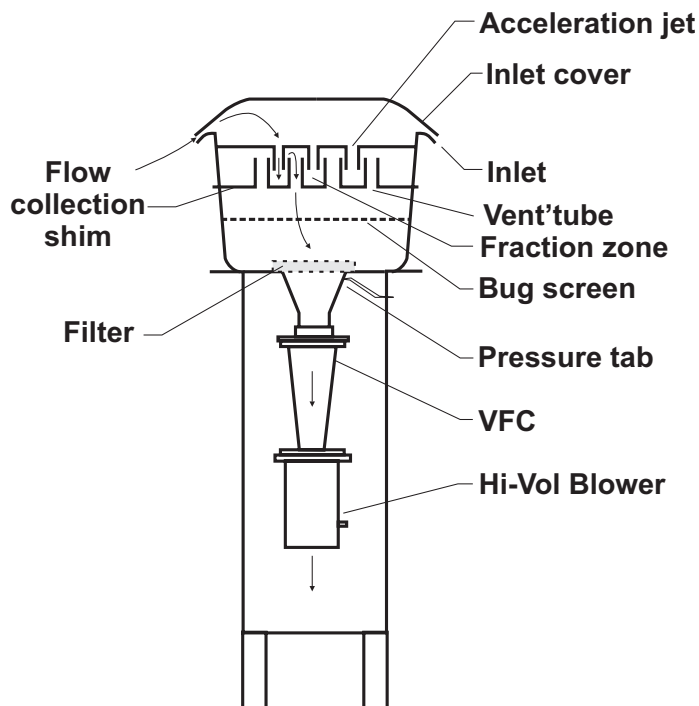

Figure 3.15.1: Schematic diagram of Sierra-Andersen/GMW Model 12000 with a volumetric flow controller (VFC).

3.15.2.1 Impactor inlet

Without any special intake (hood) of the high volume sampler the upper cut is between 50-100 μm , termed as total suspended particle matter (TSP). An intake hood should be connected to collect particles of defined size (PM₁₀); in practice this requires an impactor stage with a 50% cut-off at 10 μm a.e.d. When ambient air is drawn into the inlet, the acceleration nozzles fractionate particles larger than 10 μm , which are impacted onto a greased collection shim. The air containing the PM₁₀ particle fraction is channelled through to the filter holder. The flow rate is critical to maintain the PM₁₀ cut point and when using the standard impactor dimension, following the criteria for the CEN standard (EN 12341:1998), a constant flow rate of 68 m³/h (1133 l/min) is needed for a high volume sampler and 2.3 m³/h (38 l/min) for a low volume sampler.

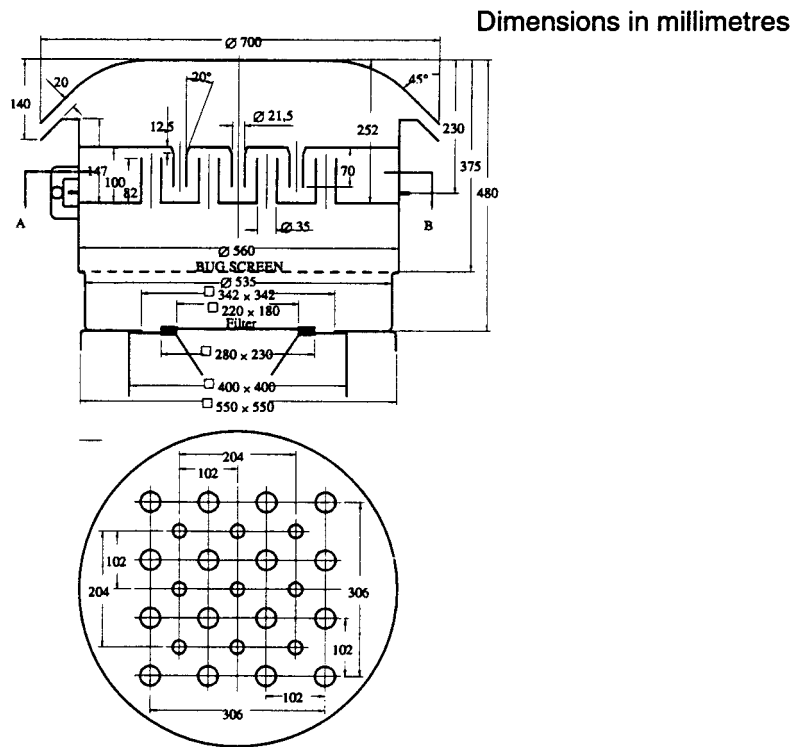

Figure 3.15.2: Design of 68 m³/h HVS-PM₁₀ sampling inlet (CEN, 1998).

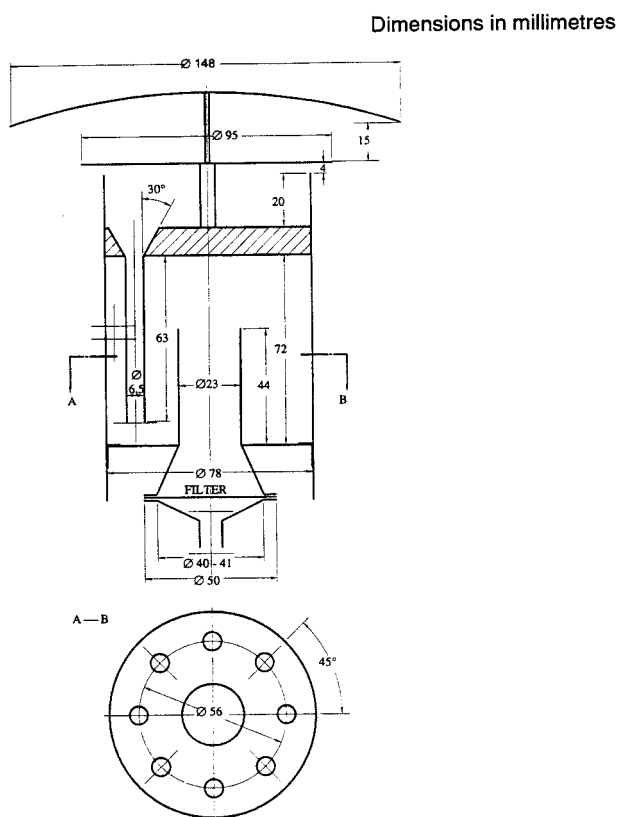

Figure 3.15.3: Design of the 2.3 m³/h MVS PM₁₀ sampling inlet (CEN, 1998).

The impaction nozzles and surface shall be cleaned and greased (e.g. with Vaseline) regularly, at least for every 20 samples. To facilitate cleaning and greasing the sampling inlet shall be constructed in such a way that the impaction plate can be pulled out of the housing. The construction and critical dimensions of the inlets of the high and low volume PM₁₀ samplers are shown in Figure 3.15.2 and Figure 3.15.3.

3.15.3 Filters

The choice of filter type is dependent on instrumentation and what type of analysis is going to be done after sampling. For PM₁₀ sampling, especially for high-volume sampling, it is necessary to use filter material with low flow resistance in order to maintain the prescribed flow rate. Quartz fibre filters should therefore be used for high-volume sampling. These filters have very good filtration characteristics with high flow and low pressure-drop, and their collection efficiency for small particles is excellent. The problem with the quartz fibre filters is their very large surface, and their adsorption of water vapour and other gases. Absorption of sulphur dioxide is not a serious problem when quartz fibre filters are used, but glass fibre and cellulose filters should not be used because of this possibility. Cellulose filters are also hygroscopic and are not suitable for particle mass measurements.

For low- or medium volume sampling, membrane filters may also be used, e.g. Teflon filters or filters made from mixed cellulose esters. But test should be carried out to see that this gives equivalent results.

When the amount of elemental- and organic carbon (EC/OC) is to be measured, sampling will have to be carried out on quartz filters. Membrane and cellulose filters contain organic material and are therefore unsuitable. Quartz filters do have the advantage that they can be baked at 500°C prior use, which may be necessary for measurements of the organic fraction to avoid high blank values. However heating filters may also result in evaporation of water in the filter structure; in addition, active sites are generated after baking the filters and volatile organic material will easier adsorb on the surface. Glass fibre filters will melt during the thermal process applied and cannot be used for sampling.

For mineral dust analysis however it is preferable to use membrane filters. Since quartz filters contain silicon and also has absorption problems when using X-ray techniques.

For heavy metal sampling, it is strongly recommended to use either Teflon or quartz filters. Glass filters do often have high blank values for certain elements.

Also cellulose filters have extensively been used for sampling of particulate matter followed by neutron activation analyses for mineral dust and trace metal analysis, but these filters cannot be used for weighing.

3.15.4 Interference

Positive interference may result from absorption of gaseous species, like SO₂ and HNO₃ on the filters followed by oxidation to sulphate and nitrate respectively.

This problems increase with filter alkalinity. If alkalinity is less than 25 microequivalent/gram filters little or no sulphate artefact should occur (EPA, 1997). Nitrate formation from nitric acid occurs on many filter types, including glass fibre, cellulose ester and quartz fibre. Nitrate can also give negative interference due to dissociation of volatile ammonium nitrate. Semi-volatile organic compounds may also cause sample weight-loss. The magnitude is dependent on location and ambient temperature.

3.15.5 Sampling procedure

In addition to the general siting criteria given in Chapter 2, it is important that the inlet is located far from any obstruction that might influence on the airflow, like building walls and trees etc. Some pumps have shown to release particles e.g. copper. Air from such pumps should therefore be removed in a separate tube at least 10 metre from the filter intake.

It is very important that the filters are stored in filter holders or in plastic bags with zippers when it is transported between the laboratory and the field. Tweezers should be used, preferably made of non-metallic material or covered with Teflon at least when heavy metals are to be determined. Never touch the filters with the fingers. After exposure the high volume filters are folded in two with the exposed side against each other, put in transport container and transferred to the laboratory for conditioning and analysis, ensuring that the filters never is exposed to higher temperature than reached during sampling.

The sampling procedures are different from one air sampling system to another. Standard operating sampling procedures (SOP) should therefore be based on the sampler's operator manual. Below some general points to remember is given:

- Inspect the filter for any pinholes, irregularities etc. If found select another one.
- Record the selected filter identification on the field log sheet.
- Always use tweezers when handling the filters. If not possible, always use anti-static powder free gloves.
- Make sure the filter is correctly placed and remember that the filters usually have a front side.
- Record the flow-rate before and after exposure or read the total flow if this is given.
- Note down the date time at the start and the end of the exposure.
- Record any unusual events, i.e. power brake down, storm, fires etc.

3.15.6 Maintenance and calibration

The sampling equipment should be maintained in accordance with the manufacturer's specifications. Accurate volume readings are important for the resulting measurement's accuracy, and the volume meters need frequent calibrations. The flow rate should be checked using a rotameter. Calibrations should under no circumstances be less frequent than twice every year. The accuracy must be better than 5%. Written instructions for maintenance and calibration need to be available at the site, and the operator should be familiar with the contents.

3.15.7 *Weighing procedure*

All handling of filters should be made in clean air. All equipment should be stored in plastic bags in a dust free environment.

It is required by EN 12341 that the filters are equilibrated, at 20° C (± 1) and 50% R.H. (± 5), for 48 hours. This equilibration should be performed before the filters are weighed previous to the sample collection, and after sampling, before the filter is weighed again with the collected sample.

Exposed filters should immediately be left to equilibrate, or stored in a fridge or cooling room ($< 10^{\circ}\text{C}$) prior to equilibration. Care must be taken to avoid condensation of water onto the filter.

Some filters are brittle, and special precautions should be taken in their handling. All the handling of filters must be done using tweezers. If one has to touch the filters, always use anti-static powder free gloves.

Filters from the high-volume sampler should be weighed to the nearest 0.1 mg. For the medium or low volume sampler, a balance capable of nearest 1 μg , should be used.

Two reference filters should be kept in the balance room and their weight checked daily. Weight changes per week should not exceed a mass which corresponds to more than 0.1 $\mu\text{g}/\text{m}^3$. If the changes are higher it might be an indication of a contamination in the conditioning/balance room. In addition one should daily weigh a standard weight to check the stability of the balance. These weights should be recorded in a logbook placed in the balance room.

Care should be taken to avoid electrostatic effects. It may be an advantage if the filters can be positioned in an upright position on the balance when the weighing is performed, at least for high volume filters. The use of ionising units, e.g. an alpha particle emitter (usually Polonium 210) is recommended, especially if membrane filters are used. For further guidance to the cause and control of static effects see: *Cahn Technical Note: Static Control for Balances*, 6/90. This document is available within the U.S. EPA's Ambient Monitoring Technology Information Center (AMTIC) PM monitoring information web page:

<http://www.epa.gov/ttn/amtic/files/ambient/pm25/qa/static.pdf>

3.15.8 *Filter blanks*

One filter blank per week is recommended. The filter blanks are to be pre-equilibrated under the same conditions as the loaded filters, they should be transported to the site, inserted into a sampler without sampling, taken out and stored in the transport container in a shelter for the sampling period, taken back to the equilibration room and weighted. If the field blank exceeds a mass that corresponds to more than 0.3 $\mu\text{g}/\text{m}^3$ it can be an indication of a contamination problem during transport or at the sampling site.

3.15.9 Commercial supply

EN 12341 specifies three reference methods for determination of PM₁₀ (CEN, 1998). Two of these, the high-volume sampler and a low -volume sampler, may be used at EMEP sites to obtain daily samples for weighing and subsequent chemical analyses. Commercial samplers that satisfy these specifications are given in the table below. Other samplers may also be used, provided that these give comparable results.

	Model	Manufacture
Low and medium volume sampler (KleinfILTERGERÄT)	ISAP 1050	Ingenieurbüro Schulze Im Heidewinkel 66 D-21271 Asendorf, Germany http://www.isap.com/
	LVS3D/ MVS6D	Ing. Büro Norbert Derenda, Bleibtreustrasse 7, D-10623 Berlin, Germany
	LVS3/ MVS6	Ing.-Büro Sven Leckel Leberstraße D-10829 Berlin, Germany http://www.leckel.de/
High volume sampler	ISAP 2000	Ingenieurbüro Schulze Im Heidewinkel 66 D-21271 Asendorf, Germany http://www.isap.com/
	ESM Andersen	ESM Andersen Instruments GmbH Frauenauracher Straße 96, D-91056 Erlangen, Germany. http://www.esm-online.de/
	DA-80 H	DIGITEL Elektronik AG Alte Gasse 18, CH-8604 Hegnau Switzerland http://www.digitel-ag.ch/
Combined gravimetric sampler and beta monitor	ADAM SM2000	Opsis AB, Box 244, SE-244 02 Furulund. Sweden http://www.opsis.se

3.15.10 References

CEN (1998) Air Quality. Determination of the PM₁₀ Fraction of Suspended Particulate Matter. Reference Method and Field Test Procedure to Demonstrate Reference Equivalence of Measurement Methods. Brussels (EN 12341).

EC (2001) Working group on particulate matter. Guidance to member states on PM₁₀ monitoring and intercomparisons with the reference method. Draft Final Report, 16 March 2001

EMEP (2000) EMEP-WMO Workshop on Fine Particles – Emissions, Modelling and Measurements, Interlaken, Switzerland, 22–25 November 1999. Kjeller, EMEP/CCC-Report 9/2000

EPA (1997) Reference Method for the Determination of Particulate Matter as PM₁₀ in the Atmosphere. *Federal Register*, 62, No 138, Appendix M to part 50.

WHO Regional Office for Europe, Copenhagen (EUR/ICP/EHB1040102, E62010, 10-13.)

WHO (1999) Particulate Matter (PM₁₀ and PM_{2.5}). Results of Intercomparison Studies. Conference Held in Berlin 3-5 September 1998.

3.15.11 Measurements of PM_{2.5} and PM_{1.0}

To harmonize the measurements of particulate matter, the EMEP manual on PM_{2.5} and PM₁ will to a large extent follow the coming reference from the European Community as it does for PM₁₀. CEN is working on a reference method for PM_{2.5}, but this is not expected to be finalized before earliest in 2004. Even though a reference method is not yet adopted it is highly desired to include the measurements of smaller particles as soon as possible. PM_{2.5} and PM₁ has a larger fraction of long rang transported components than the PM₁₀ which in many cases are influenced by local pollution and/or resuspension. Those countries interested in starting PM_{2.5} and/or PM₁ measurements are encouraged to use one of the candidate CEN reference instrument and this manual for a general guidance on sampling and analyzing methods. For PM₁ it is not yet any CEN group established to decide on a reference method, but one may still use any of the reference or candidate instruments for PM₁₀ or PM_{2.5} with a PM₁ inlet. Some companies manufacturing PM₁ inlets are listed below.

3.15.11.1 List of Candidate CEN PM_{2.5} reference instruments

- MINI-WRAC, *gravimetric, single filter* from [Fraunhofer Institute for Toxicology and Aerosol Research](#) (FhG-ITA), Germany
 - [RAAS 2.5-1](#), *gravimetric single filter* from [ESM Andersen](#), USA
 - LVS 3D, *gravimetric, single filter* from Derenda Company, Germany
 - [Partisol Plus](#), *gravimetric, sequential* and Partisol WINS, *gravimetric, single filter* from [Rupprecht & Patashnick](#), USA
 - SEQ 47/50, *gravimetric, sequential* from [Leckel Company](#), Germany
 - HVS-HDI 2, *gravimetric, sequential* from [Digitel Company](#), Switzerland
- Candidate Equivalence Instruments (automated)*
- ADAM, *beta method, sequential* [Opsis](#), Sweden

- TEOM SES, *sharp cut cyclon* [Rupprecht & Patashnick](#), USA
- FHG 2 I-R, *beta method, filter tape* [ESM Andersen Company](#), Germany
- BAM-1020, *beta method, filter tape* [Met One](#), USA

3.15.11.2 Manufactures with $PM_{1.0}$ inlet

- Cyclonic separation [PM-1 Inlet](#) from [Rupprecht & Patashnick](#), USA
- The PMX INLET from [Leckel Company](#), Germany
- The [Dekati](#) PM-10 impactor measure PM_{10} , $PM_{2.5}$, and PM_1 concentrations simultaneously.
- Standard and impactor sampling heads (PM_{10} , $PM_{2.5}$, $PM_{1.0}$) for ISAP2000 with optionally heating from [Schultze](#)
- Sharp Cut Cyclone, PM_1 ([SCC-2229](#)) from [BGI](#) incorporated, USA

4. Chemical analysis

4.1 Determination of sulphate, nitrate, chloride, ammonium, sodium, potassium, calcium, and magnesium with ion chromatography

4.1.1 Scope and Application

Ion chromatography can be used for the determination of the ions in the following samples:

- Precipitation
- Extracts of aerosol filters
- Extracts of impregnated filters
- Extracts of coated denuders

The pretreatment of the samples before analysis is described together with the sampling in the preceding Sections. Special conditions for the different sample matrices are given in these Sections.

The concentration range of the method is typically 0.01–10 µg/ml.

4.1.2 Principle

A small volume of the sample, typically less than 0.5 ml, is introduced into the injection system of an ion chromatograph. The sample is mixed with an eluent and pumped through a guard column, a separation column, a suppressor device and a detector, normally a conductivity cell.

The separation column is an ion exchange column which has the ability to separate the ions of interest. The separation column is often preceded by a shorter guard column of the same substrate as in the separation column to protect the separation column from overloading and particles. Different types of separation columns, eluents and suppression devices have to be used for anions and cations respectively. Each ion is identified by its retention time within the separation column. The sample ions are detected in the detection cell, and the signals produced (chromatograms) displayed on a strip chart recorder or a PC equipped with the necessary software for measurement of peak height or area.

The ion chromatograph is calibrated with standard solutions containing known concentrations of the ions of interest. Calibration curves are constructed from which the concentration of each ion in the unknown sample is determined.

4.1.3 Interferences

Any species with a retention time similar to that of the main ions could interfere. With the exception of NO_2^- , precipitation or filter extracts do normally not contain such species. Large amounts of one of the ions may interfere by reducing the peak resolution of the next ion in the elution sequence. Sample dilution can then be necessary.

In some systems the so-called negative water dip in the start of the chromatogram may interfere with the Cl^- determination. This can be avoided by adding a small

amount of concentrated eluent to all samples and calibration standards to match the eluent concentration.

When analyzing alkaline impregnated filters and denuders, the sample matrix may influence the shape of the chromatogram peak and give wrong results if comparisons are made with calibration standards made from pure water solutions. In some cases this can be avoided by using the peak area instead of the peak height, but using the peak area in the low concentration range may often fail.

It is strongly recommended to match the calibration solutions with the sample matrix. For some samples, e.g. extracts from impregnated filters, the sample matrix may cause a slight distortion of the chromatogram. This may cause erroneous results if the calibration solution does not have a similar ionic composition. If ordinary calibration solutions are used, it must regularly be checked if this causes a problem by using control samples with known concentration of the ions with the same matrix as in the samples. One way of doing this is to extract unexposed impregnated filters with the normal calibration standards and with the same volume of water as the samples. Analyses of these samples should not give deviating results from the calibration standard concentrations.

Samples that contain particles larger than 0.45 μm and reagent solutions that contain particles larger than 0.20 μm require filtration to prevent damage to the instrument columns and flow systems. If the sample is left undisturbed in the sample tube for some days before analysis, these problems can be avoided by simply place an in-line filter in the tubing in front of the columns.

The presence of air bubbles in the columns, tubing or conductivity detector cell will cause baseline and peak variability. Using boiled solutions as eluents will help to minimize the introduction of air.

4.1.4 Instrumentation

Different commercial instruments are available using different columns and suppressor devices. Two main types of instruments using different suppressor techniques, chemical and electronic suppression, are on the market. One example of specific equipment for each of these two types is given below. The examples below do not exclude a use of other commercial equipment which allow the analyses to be carried out with the required accuracy and precision.

4.1.4.1 The Dionex (Dionex Corporation, Sunnyvale, CA, USA) system

Modern versions of Dionex instruments are usually equipped with injection valve, pump constructed from inert material (both gradient and isocratic pumps are available), separation column, suppressor system and a conductivity detector (in some cases a UV/Vis absorbance detector may be used). The instruments may be operated with manual injection or automated using an autosampler. The chromatograms are recorded on a strip-chart recorder, an integrator or direct on a PC-based Chromatography Workstation.

The chemical suppressor in the Dionex system has undergone significant improvements during the last years, as ordinary packed ion exchange columns which had to be chemically regenerated, have been replaced initially by hollow fibre suppressors and then by micro-membrane suppressors with higher suppression capacity and a smaller dead volume. The last versions of these suppressors are equipped with a self-regenerating system based on electrolysis of water from the eluent itself.

Table 4.1.1 shows the guard columns, separation columns and suppressors which are recommended for the different sample types in 1994.

Table 4.1.1: Columns and suppressors recommended by Dionex in 1994.

	Samples	Separation/ Guard columns	Suppressor
Anions	All types mentioned above	AS9-SC/AG9-SC	AMMS-II or ASRS, 4mm
	All samples excluding KOH-impregnated filters	AS4A/AG4A	AMMS-II or ASRS, 4mm
Cations	(Both monovalent and divalent) Aerosol filters and precipitation	CS12/CG12	CSRS, 4mm

Producers of ion chromatographs also specify the eluent to be used and its concentration. Therefore no specific instructions regarding eluents are given in this manual. The column is delivered with a test chromatogram showing the separation of the different ions and the retention times. When installing a new column, it should be checked if the performance is as stated in the test chromatogram.

For other details on running the instruments, reference is made to the appropriate Instrument Manual.

4.1.4.2 The Waters (Waters Association, Milford, MA, USA) system

The Waters system is an electronically suppressed system, i.e. without a chemical based device to reduce the conductivity of the eluent, but with the possibility to subtract the conductivity of the eluent.

The following description of one possible instrument set-up and column choice is given by the Air Quality Department of Finnish Meteorological Institute (FMI):

Equipment

Pump	Waters HPLC pump Model 501 (with pulsation suppression)
Injector and autosampler	Waters Model 712 WISP and Waters Model 717 96 or 48 samples analyzed sequentially
Detector	Waters Model 431
Microcomputer	NEC 486/66i, 20/240 MB
Software	Waters Maxima 820 and Baseline

Conditions for anions (precipitation, aerosol filters and alkaline impregnated filters)

Eluent	Borate/Gluconate
In-line filter	Waters Guard Pak (0.22 µm)
Column	Precipitation and aerosol filters: Waters IC-Pak A HR (4.6 x 75 mm, 6µm, 30 ± 3 µeq/ml) Impregnated filters: Waters IC-Pak A (4.6 x 50 mm, 10µm, 30 ± 3 µeq/ml)
Flow rate	IC-Pak A HR: 1.0 ml/min IC-Pak A: 1.2 ml/min
Injected volume	20-200 µl
Run time	Appr. 16 min (Cl ⁻ , NO ₃ ⁻ , SO ₄ ²⁻)

Conditions for cations (precipitation samples)

Eluent	EDTA/HNO ₃
In-line filter	Waters (0.22µm, Cat no. 32472, Millipore)
Column	Waters IC-Pac C M/D (3.9 x 150 mm, 5 µm, 2.0 ± 0.2 meq/ml)
Flow rate	1.0 ml/min
Injected volume	20-200 µl
Run time	Ca. 18 min (NH ₄ ⁺ , Na ⁺ , K ⁺ , Mg ⁺⁺ , Ca ⁺⁺)

Detection limits

The analytical detection limits (in mg/l) obtained at FMI with the described equipment, defined as 2x (peakheight of lowest standard/height of baseline noise), are given in Table 4.1.2.

Table 4.1.2: Detection limits for Waters systems at FMI.

	Detection limits	Lowest calibration standard
Cl ⁻	0.010	0.05
NO ₃ ⁻ -N	0.010	0.05
SO ₄ ²⁻ -S	0.020	0.05
NH ₄ ⁺ -N	0.002	0.02
Na ⁺	0.002	0.02
K ⁺	0.006	0.02
Mg ⁺⁺	0.003	0.02
Ca ⁺⁺	0.005	0.02

More practical hints on the use of the Waters system written by Anni Reissell, FMI are available from the CCC.

4.1.5 Reagents and standards

All reagents must be of recognized analytical grade. The water used for dilution should be deionized and filtered. The water should have a resistance $> 10 \text{ M}\Omega/\text{cm}$ and not contain particles larger than $0.20 \text{ }\mu\text{m}$. The sample, calibration standards and reagent solution bottles should be made of polyethylene or polypropylene. For the anions, borosilicate glass may also be used.

4.1.5.1 Eluent solutions

The chemicals and concentrations to be used are normally given by the manufacturers of the different separation columns.

4.1.5.2 Stock standard solutions

Stock standard solutions e.g. 1000 mg (based on the element)/litre, may be purchased as certified solutions from different manufacturers or NIST (National Institute for Standards and Technology, USA), or prepared from salts or oxide dried in the prescribed way, dissolved and diluted to 1000 ml as listed in Tables 4.1.3 and 4.1.4:

Table 4.1.3: Preparation of stock standard solutions. The salt amount indicated gives 1000 mg of the anions per litre.

Salt	Weight (g)	Drying temp. °C	Drying time (hours)
NaCl	1.6485	150	1
Na NO ₃	6.0679	105	2
Na ₂ SO ₄	4.4299	105	24

Table 4.1.4: Preparation of stock standard solutions. The salt amount indicated gives 1000 mg of the cations per litre.

Salt	Weight (g)	Drying temp. °C	Drying time (hours)
NH ₄ Cl	3.8190	105	1
NaCl	2.5421	150	2
KCl	1.9067	105	1
CaCO ₃	2.4971	180	1
MgO	1.6581	–	–

The CaCO₃ should be added to approximately 600 ml of water. Then add concentrated hydrochloric acid (HCl) slowly until the entire solid has dissolved, and dilute to 1000 ml with water.

The MgO should be dissolved in 10 ml concentrated nitric acid (HNO₃) before diluting to 1000 ml with water.

The other salts should be dissolved directly in water.

These stock standards are stable for at least 1 year.

4.1.5.3 Calibration solutions

Five calibration solutions and one zero standard (blank, normally water) are needed to generate a suitable calibration curve. The range to be used will depend on the concentration range for the different samples.

One example is given for each of the ion types:

0, 0.5, 1.0, 2.5, 5.0 and 10.0 ml of each of the anion stock standards are transferred with calibrated pipettes to 1000 ml volumetric flasks and diluted to volume with deionized water. These calibration standards will contain 0, 0.5, 1.0, 2.5, 5.0 and 10.0 mg/l respectively calculated on the basis of Cl, NO₃-N and SO₄-S.

0, 0.5, 1.0, 2.5, 5.0 and 10.0 ml of each of the cation stock standards are transferred with calibrated pipettes to 1000 ml volumetric flasks and diluted to volume with deionized water. These calibration standards will contain 0, 0.5, 1.0, 2.5, 5.0 and 10.0 mg/l respectively calculated on the basis of NH₄-N, Na, K, Ca and Mg.

If control samples have shown the necessity to match the matrix in the calibration solutions with the sample matrix (see 4.1.3 Interferences), addition of the matrix must be done before diluting to volume.

The calibration standards may be stored for 3 months in acid-cleaned polyethylene or polypropylene containers in a refrigerator. Special attention should be paid to control contamination from ammonia in the laboratory air.

4.1.6 Procedure

The ion chromatograph should be operated according to the manufacturers description.

The calibration solutions and control samples should be used as described in Section 5.

The width of the retention time window used to make identifications should be based on measurements of actual retention time variations of standards over the course of a day. Three times the standard deviation of a retention time can be used to calculate a suggested window size for each ion.

However, it is important to use the experience of the analyst in the interpretation the chromatograms.

4.1.7 Calculation of the results

The concentration of the different ions in the sample solutions are found by using the calibration curve manually or directly from a computer or integrator. To calculate the air concentrations for air samples from these values, use the appropriate formulas given in the actual sections on sampling.

4.1.8 References

Small, H. (1989) Ion Chromatography. New York, Plenum Press.

4.2 Determination of sulphate in precipitation

Although ion chromatography is the method of choice for the determination of sulphate, spectrophotometric determination with barium perchlorate and thorin will also give useful results, particularly if the determination is automated (Autoanalyser or FIA).

4.2.1 Spectrophotometric by the barium perchlorate-Thorin method

4.2.1.1 Field of application

This method is applicable to the determination of sulphate in precipitation within the range 0.05 mg S/l to 4 mg S/l. Samples containing higher concentrations must be diluted prior to the analysis.

4.2.1.2 Principle

Ba(ClO₄)₂ is added in excess to precipitate the sulphate as barium sulphate in an organic solvent. The organic solvent will minimize the solubility product of barium sulphate.

The excess concentration of barium (II) ions in the solution is determined spectrophotometrically at 520 nm through the reaction with Thorin (the sodium salt of 4-(ortho-arsenophenyl-azo)-3-hydroxy-2,7-naphthalenedisulphonic acid).

Several organic solvents may be used. The most favourable calibration curve is obtained with dioxane.

4.2.1.3 Instrumentation

- Spectrophotometer for measuring absorbance at 520 nm.
- Optical glass spectro-photometer cells; 20 mm
- Micro pipette: 250 µl
- Bulb pipettes: 1, 2, 3, 4, 5, 6, 7, 8, 9 and 10 ml
- Burette: 50 ml
- Ion exchange columns: 15 cm length, 1 cm diameter
- Test tubes: 30 ml
- Volumetric flasks: 50, 100 and 1000 ml

All glassware should be of borosilicate and should be thoroughly rinsed in distilled water before use.

4.2.1.4 Chemicals

All chemicals, except Thorin, must be of recognized analytical grade. The water used for dilution and rinsing must be double distilled or deionized.

- Sulphuric acid (H₂SO₄) 0.05 M
- Perchloric acid, (HClO₄) 72 %
- Barium perchlorate (Ba(ClO₄)₂), anhydrous
- Dioxane or isopropanol

- Thorin (disodium salt)
- Cation exchange resin, strongly acidic (e.g. Dowex 50 W x 8, 50-100 mesh).

4.2.1.5 Reagents

- (1) 0.1 M perchloric acid (HClO₄).
- (2) 0.01 M perchloric acid (HClO₄).
- (3) Barium perchlorate stock solution 210.0 mg anhydrous barium perchlorate, (Ba(ClO₄)₂), is dissolved in 0.1 M HClO₄ to a volume of 100 ml in a volumetric flask.
- (4) Barium perchlorate reagent solution 10.0 ml of solution (3) is diluted to 1000 ml with dioxane or isopropanol.
- (5) Thorin reagent solution 125.0 mg of the disodium salt is dissolved in 5 ml 0.01 M HClO₄ and diluted to 50 ml in a volumetric flask. A fresh solution should be prepared each day.
- (6) Sulphate standard solution 31.25 ml 0.05 M H₂SO₄ is diluted to 1000 ml in a volumetric flask. The concentration is equal to 50 mg S/l.

4.2.1.6 Calibration

Prepare a series of standard solutions containing 0, 0.5, 1.0, 1.5 4 mg S/l by diluting 0, 1, 2, 3, 8 ml of the sulphate standard solution in Section 4.2.1.5 (6) to 100 ml with water in volumetric flasks. Transfer 4 ml of each of these standard solutions to a test tube. Add 10 ml barium perchlorate reagent solution and 250 µl Thorin solution. Use a micro pipette for the Thorin solution. Mix thoroughly (do not use rubber stoppers!)

Transfer the solutions to optical cells. The spectrophotometer wavelength is set at 520 nm, and 0% transmission is adjusted according to the procedure in the manual of the photometer. Then gain and/or slit width is adjusted to give a reading of 0.80 absorbance units with the blank (0 mg S/l) in the sample compartment. Measure the absorbance of the solutions within 10 minutes after addition of the Thorin solution. This is especially important for low concentrations of sulphate and for the blank because the barium-Thorin compound may precipitate from the solution.

A calibration graph is constructed from the absorbance readings obtained from the standard solutions. The calibration curve is not linear below 0.5 mg S/l. This is suppressed by adding sulphate in a quantity corresponding to 0.5 mg S/l to all samples and blanks. The detection limit is then 0.05 mg S/l.

4.2.1.7 Analytical procedure

Cations are removed by treating the sample with a strongly acidic cation exchange resin.

Transfer 4 ml of the pretreated sample to a test tube and proceed according to Section 5.2.1.6.

Determine the sulphur concentration of the sample from the absorbance reading by means of the calibration curve.

With suitable equipment, the barium perchlorate-Thorin method can be made automatic. This method is described in detail in the next Section.

4.2.1.8 Interferences

Phosphate will interfere with this method.

4.2.1.9 References

Persson, G.A. (1966) Automatic colorimetric determination of low concentrations of sulphate for measuring sulphur dioxide in ambient air. *Air Water Pollut.*, 10, 845-852.

4.2.2 Automatic Spectrophotometric by the barium perchlorate-Thorin method

4.2.2.1 Field of application

This automatic method can be used to determine the concentration of sulphate in precipitation within the range 0.05 to 2.5 mg S/l.

4.2.2.2 Principle

The basis principle is the same as in the manual method above.

A known amount of $(\text{Ba}(\text{ClO}_4)_2)$ is added in excess to the sample and the sulphate is precipitated as barium sulphate. The excess of barium ions reacts with the Thorin indicator to form a red compound. The concentration is determined colorimetrically at 520 nm.

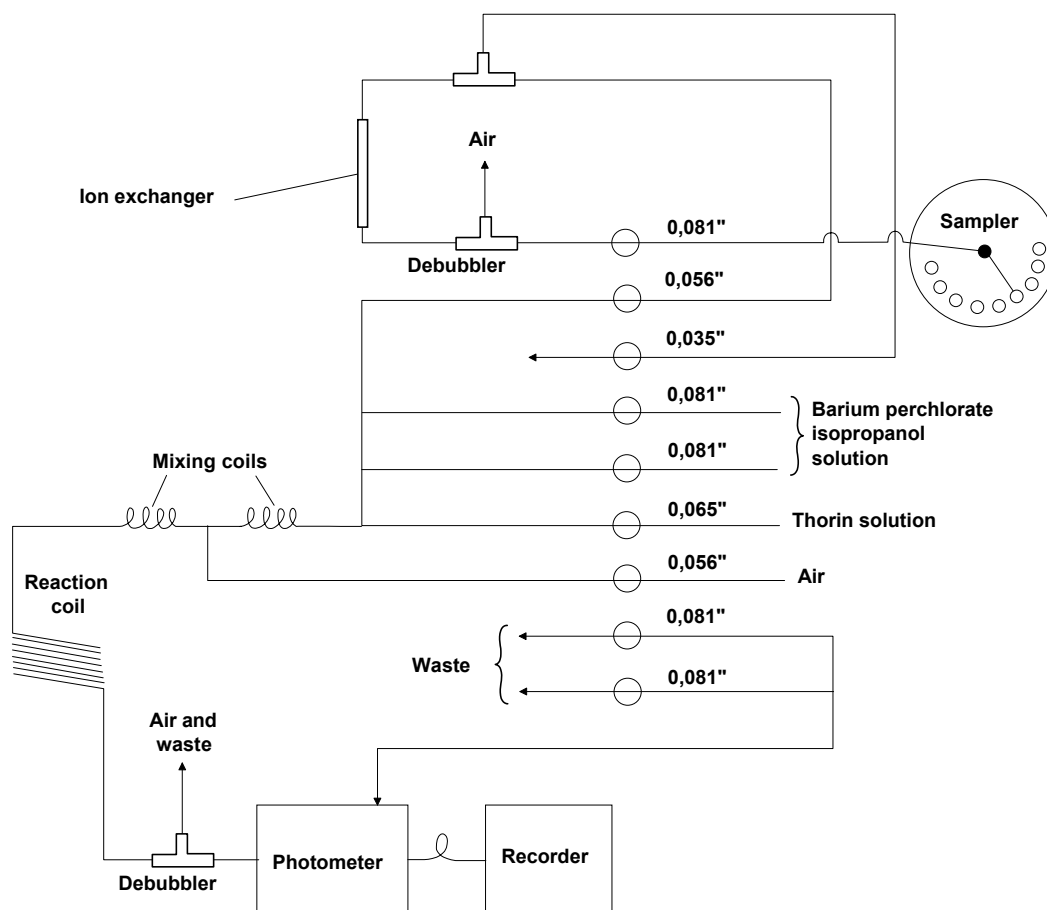

Figure 4.2.1: Flow scheme for automatic spectrophotometric analysis of sulphate.

4.2.2.3 Instrumentation

- Automatic sampler with 6 ml cups
- Peristaltic pump
- Filter photometer with power supply and recorder output.
- Flow cell, pathlength 1.0 cm
- Filter, transmission 520 nm
- Recorder with zero suppression up to 100%
- Cation exchange column: A 10 cm glass (or polyethylene) tube i.d. 2 mm filled with a strongly acidic cation exchange resin. Glass wool in both ends of the tube keeps the resin in place. The resin should always be moist.
- Flexible tubings, connecting tubes, pulse suppressors, debubblers and mixing coils.

4.2.2.4 Chemicals

All chemicals, except Thorin, must be of recognized analytical grade. The water used must be double-distilled or deionized.

- Isopropanol ((CH₃)₂CHOH)
- Barium perchlorate (Ba(ClO₄)₂ anhydrous)

- Perchloric acid (HClO₄)
- Thorin (disodium salt)
- Sulphuric acid (H₂SO₄) 0.05 M
- Sodium acetate (CH₃COONa)
- Acetic acid (CH₃COOH)
- Cation exchange resin, strongly acidic (e.g. Dowex 50 W x 8, 50-100 mesh).
- EDTA (disodium salt)
- Sodium hydroxide (NaOH)

4.2.2.5 Reagents

- (1) Barium perchlorate solution:
Dissolve 900 mg (Ba(ClO₄)₂) in 1000 ml water and add 8.6 ml of HClO₄.
- (2) Sodium acetate buffer:
Add 1M CH₃COOH to 100 ml 1M sodium acetate to pH 5.6.
Use a pH-meter.
- (3) Barium perchlorate - isopropanol reagent:
To 1000 ml of isopropanol, add 10 ml of barium perchlorate solution (1) and 4 ml of sodium acetate buffer (2).
Mix well.
- (4) Thorin solution:
Dissolve 100 mg of Thorin in a little water in a 500 ml volumetric flask. Fill up to the mark with water. Prepare a fresh solution every day.
- (5) Standard sulphate solution, 50 mg S/l:
Transfer 31.25 ml of 0.05 M H₂SO₄ to a 1000 ml volumetric flask using a burette. Dilute to 1000 ml with water. Store refrigerated.
- (6) Cleaning solution:
100 g of EDTA and 10 g NaOH are diluted to 2 litres with water.

4.2.2.6 Calibration and analytical procedure

Prepare a series of standard solutions containing 0.0, 0.1, 0.5, 1.0 2.5 mg S/l by diluting 0, 2, 10, 20 50 ml of the standard sulphate solution (5) to 1000 ml with water in volumetric flasks.

Start the pump and check the flow, all connections, tubings and debubblers with water running through the instrument. Turn on the photometer and the recorder (paper speed 5 mm/min.). Connect the tubings to the reagents and check that the baseline is stable.

Fill the cups of the automatic sampler with samples and standard solutions. Sampling time is 130 seconds and rinsing time with water after each sample is 180 seconds. Start with the series of standard solutions, and run a series of standard solutions after every tenth sample.

When isopropanol is used as organic solvent, the tubings must be thoroughly cleaned after use. Flush water through the system until all the reagents are rinsed out, then run the cleaning solution for 5 minutes. Rinse again with water. Turn off the recorder, photometer, sampler and pump, and loosen the tubings in the pump so they are not stretched.

Prepare a calibration curve from each of the series of standard solutions by plotting the recorder response in mm (absorbance) against the concentration of the standards.

4.2.2.7 Expression of results

Convert the recorder response (absorbance) of the sample to mg S/l by means of the calibration curve obtained just before or after the sample.

The use of a transparent sheet with several vertical scales corresponding to the different responses from the standard solutions will save time when many samples are to be handled.

4.2.2.8 References

Henriksen, A. and Bergmann-Paulsen, I.M. (1974) An automatic method for determining sulphate in natural soft water and precipitation. *Vatten*, 2, 187-192.

Persson, G.A. (1966) Automatic colorimetric determination of low concentrations of sulphate for measuring sulphur dioxide in ambient air. *Air Water Pollut.* 10, 845-852.

4.3 Determination of nitrate in precipitation

Ion chromatography is the preferred method for determination of nitrate, spectrophotometric determination either the manual or the automatic method can also be used and will give useful results. It should, however, be noted that the Griess method in both versions described in the following gives the sum of nitrate and nitrite.

4.3.1 The manual spectrophotometric Griess method

4.3.1.1 Field of application

This method is applicable to the determination of the nitrate content in precipitation with the range 0.02-0.23 mg NO₃-N/l (0.1-1.0 mg NO₃/l).

4.3.1.2 Principle

Nitrate is reduced to nitrite using cadmium treated with copper sulphate as a reducing agent, in presence of ammonium chloride. Thus, by this method the sum of nitrate and nitrite is determined.

Nitrite and sulphanilamide form a diazo compound which couples with N-(1-naphthyl)-ethylenediamine-dihydrochloride to form a red azo dye. The concentration in the solution is determined spectrophotometrically at 520 nm.

4.3.1.3 Instrumentation

- Spectrophotometer
- Optical glass cell, 20 mm. If more than one cell is used, the cells should be matched photometrically.
- Shaking machine
- Erlenmeyer flasks: 25 ml with stoppers
- Volumetric flasks: 100 and 1000 ml
- Test tubes
- Pipettes: 1.0, 2.0, 4.0, 6.0, 8.0, 12.0 and a 20.0 ml graduated
- Micro pipettes: 100, 250, 500 µl
- pH-meter
- Beaker: 200 ml

4.3.1.4 Chemicals

During analysis, use only chemicals of recognized analytical grade. The water used for dilution and rinsing must be double-distilled or deionized and distilled.

- Ammonium chloride (NH₄Cl)
- Sulphanilamide
- (1-naphthyl)-ethylenediamine dihydrochloride
- Cadmium, 40-60 mesh
- Copper sulphate (CuSO₄·5H₂O)
- Hydrochloric acid (HCl)
- Potassium nitrate (KNO₃)
- Ammonia (NH₃)

4.3.1.5 Reagents

- (1) 5% ammonium chloride solution:
Dissolve 5 g ammonium chloride in water in a 100 ml volumetric flask. Adjust the pH of the solution to 8.6 using diluted ammonia. Dilute with water to the mark.
- (2) 1.2 M hydrochloric acid:
Dilute 10 ml concentrated hydrochloric acid to 100 ml with water in a volumetric flask.
- (3) 2 M hydrochloric acid:
Dilute 16.7 ml concentrated hydrochloric acid to 100 ml with water in a volumetric flask.
- (4) 1% sulphanilamide solution:
Dissolve 1.0 g of sulphanilamide in some 1.2 M hydrochloric acid (2) in a 100 ml volumetric flask. Dilute with 1.2 M hydrochloric acid (2) to the mark.
- (5) 0.1% N-(1-naphthyl)-ethylenediamine dihydrochloride solution:
Dissolve 0.1 g N-(1-naphthyl)-ethylenediamine dihydrochloride in some water, in a 100 ml volumetric flask. When all is dissolved, dilute to the mark.
- (6) 2% copper sulphate solution:
Dissolve 2.0 g copper sulphate in water in a 100 ml volumetric flask, and dilute to the mark.
- (7) Reducing agent for nitrate:
Transfer 10 g of cadmium to a beaker, add 2 M hydrochloric acid (3) to cover the cadmium and stir. Rinse well with water. Add immediately 100 ml of the 2% copper sulphate solution (6), and mix well. Pour off excess of solution. Rinse with water until there is no more precipitated copper in the washing water. The reducing agent must not be exposed to the air.
- (8) Standard nitrate solution I, 1000 mg NO₃/l:
Dissolve exactly 1.6305 g potassium nitrate in water in a 1000 ml volumetric flask. Dilute to the mark.
- (9) Standard nitrate solution II, 100 mg NO₃/l:
Dilute 10 ml of standard nitrate solution I with water to 100 ml in a volumetric flask.

4.3.1.6 Calibration

Preparation of the calibration curve:

- (1) Transfer to 100 ml volumetric flasks 0, 100, 250, 500 and 1000 µl of standard nitrate solution II. Dilute with water to the mark and mix well. The

concentration of nitrate in the five flasks are 0.0, 0.1, 0.25, 0.50 and 1.00 mg NO₃/l.

- (2) By means of a pipette, transfer 4.0 ml of each of these standard solutions to a 25 ml Erlenmeyer flask. Add 6.0 ml 5% ammonium chloride solution using a pipette, and approximately 0.5 g of the nitrate reducing agent to the Erlenmeyer flask. Shake vigorously for 10 minutes. Transfer 8.0 ml of this solution by means of a pipette to a test tube. Add 2.0 ml 1% sulphanilamide solution and 2.0 ml of 0.1% N-(1-naphthyl)-ethylenediamide dihydrochloride solution using pipettes. Mix well, and leave for 10 minutes for the colour to develop. Transfer this solution to a 20 mm cell. Measure the absorbance of the solution at 520 nm.

Prepare a calibration curve by plotting the absorbance of each of the standard solutions against its concentration of nitrate.

4.3.1.7 Analytical procedure

Transfer 4.0 ml of the precipitation sample to a 25 ml Erlenmeyer flask, using a pipette. Proceed according to Section 4.3.1.6 (2).

Convert the absorbance of the sample to mg NO₃/l by means of the calibration curve. The concentration may be expressed as mg N/l by multiplying with 0.226.

Samples containing more than 1 mg NO₃/l must be diluted before the analysis.

Do not waste the cadmium used in the analysis. It may be regenerated and used again.

With suitable equipment this method can be made automatic. A detailed description of the automatic method is given in Section 4.3.2.

4.3.1.8 References

Morris, A.W. and Riley, J.P. (1963) The determination of nitrate in sea water. *Anal. chem. Acta*, 29, 272-279.

4.3.2 Automatic spectrophotometric Griess method

4.3.2.1 Field of application

This method can be used to determine the concentration of nitrate in precipitation within the range 0.03-1.13 mg NO₃-N/l (0.13-5.0 mg NO₃/l). The method can be extended to include determination of ammonium in solutions, see Section 4.4.2 and Figure 4.3.1.

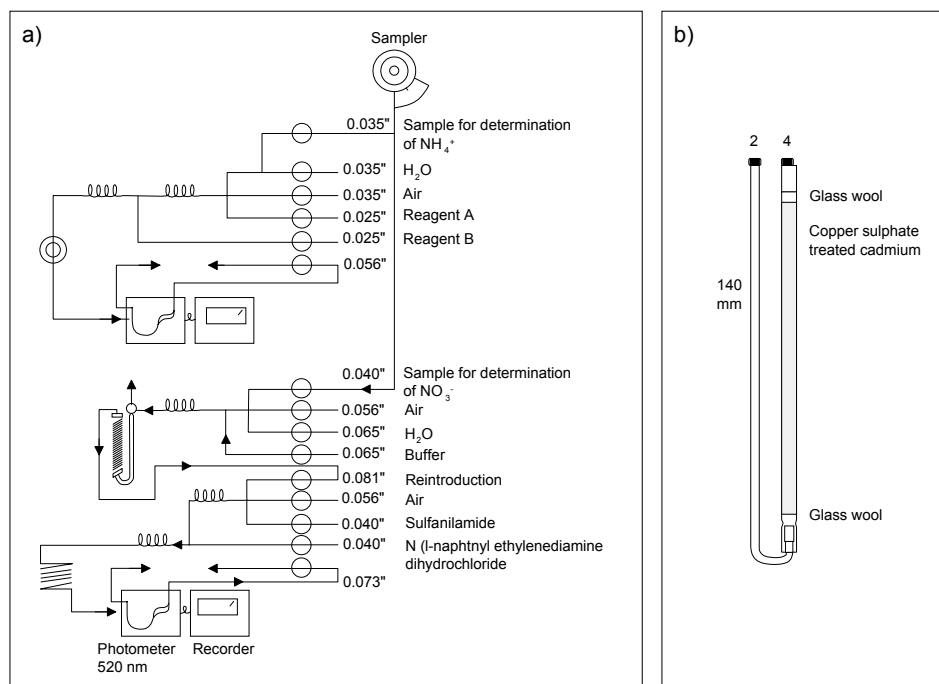

Figure 4.3.1: a) Automatic determination of nitrate and ammonium in precipitation samples.
 b) Reduction column for the determination of nitrate in precipitation samples.

4.3.2.2 Principle

The basis principles are the same as for the manual methods (see Section 4.3.1).

Nitrate is reduced to nitrite using cadmium treated with copper sulphate as reducing agent in the presence of ammonium chloride. Nitrite and sulphanilamide form a diazo compound which couples with N-(a-naphtyl)-ethylenediamine dihydrochloride to give a red azo dye. The concentration of the nitrate in the solution is determined spectrophotometrically at 520 nm. By this method the sum of nitrate and nitrite is determined.

4.3.2.3 Instrumentation

- Peristaltic pump, 20-channels
- Automatic sampler with 4 ml cups
- Photometer(s) for measuring absorbance at 520 nm (and 630 nm if ammonium is determined with the same equipment)
- Recorder(s)
- Oil bath with thermostat, 70° C
- Flexible tubings, connecting tubes, pulse suppressors, debubblers, mixing coils and reduction column (Figure 4.3.1).
- Pipettes: 50, 25, 20, 10, 5, 2.5 and 2 ml
- Analytical balance
- Desiccator

4.3.2.4 Chemicals

All chemicals must be of recognized analytical grade. The water used for dilution and rinsing must be double-distilled or de-ionized and distilled.

- Ammonium chloride (NH_4Cl)
- Ammonia (NH_3)
- Sulphanilamide
- N-(1-naphthyl)-ethylenediamine dihydrochloride
- Cadmium, 40-60 mesh
- Copper sulphate ($\text{Cu SO}_4 \cdot 5\text{H}_2\text{O}$)
- Potassium nitrate (KNO_3)
- Hydrochloric acid (HCl)

4.3.2.5 Reagents

Reagents for the determination of nitrate:

- (1) Buffer solution:
Dissolve 100 g ammonium chloride in ca. 700 ml water in a 1000 ml volumetric flask. Adjust pH to 8.6 with diluted ammonia. Dilute with water to the mark.
- (2) Sulphanilamide solution:
Dissolve 10 g sulphanilamide in a 10% HCl solution in a 1000 ml volumetric flask. Dilute with the acid solution to the mark.
- (3) 0.1% N-(1-naphthyl)-ethylenediamine dihydrochloride solution:
Dissolve 1 g N-(1-naphthyl)-ethylenediamine in some water in a 1000 ml volumetric flask. When all is dissolved, dilute to the mark with water.
- (4) Reducing agent:
Prepare a 2% copper sulphate solution. Wash the cadmium with 0.1 M hydrochloric acid and water. Add some of the 2% copper sulphate solution to the freshly washed cadmium and stir for 1–2 min. Pour off the solution and wash the reducing agent with water. Repeat until the washing water is clear. Fill the column as shown in Figure 1b. The reducing agent must not be exposed to air.

The reducing agent may be recovered in the following way:

Remove the cadmium from the column and wash with 0.1 M hydrochloric acid. Add some of the 2% copper sulphate solution and stir until the blue colour of the solution has disappeared.

- (5) Standard solutions (for nitrate and ammonium):
Standard solution I, 500 mg NO_3/l and 200 mg NH_4/l :
Dry potassium nitrate and ammonium sulphate for 1 hour at 105 °C, and then cool for 20 minutes in a desiccator.

Dissolve exactly 0.815 g potassium nitrate and exactly 0.735 g ammonium sulphate in water in a 1000 ml volumetric flask. Dilute to the mark with water. Store the solution refrigerated in the dark.

- 6) Standard solution II, 5.0 mg NO₃/l and 2.0 mg NH₄/l:
Dilute 5 ml of standard solution I (5) to 500 ml with water in a volumetric flask.

4.3.2.6 Calibration and analytical procedure

Prepare a series of calibration solutions according to Table 4.3.1.

Table 4.3.1: Calibration solutions for nitrate and ammonium.

Calibration solution No.	mg NO ₃ /l	mg NH ₄ /l	
1	5.0	2.0	Standard solution II
2	2.5	1.0	Dilute 100 ml of standard solution II to 200 ml with water
3	0.5	0.2	Dilute 20 ml of standard solution II to 200 ml with water
4	0.25	0.10	Dilute 10 ml of standard solution II to 200 ml with water
5	0.125	0.05	Dilute 5 ml of standard solution II to 200 ml with water
6	0.0	0.0	Water

These solutions may be stored in the refrigerator for a few days.

Start the pump and check the flow, all connections, tubings and debubblers with water running through the instrument. Turn on the photometers and the recorders (paper speed 10 mm/min.). Connect the tubings to the reagents and check that the baseline is stable.

Avoid air in the column containing the reducing agent. Therefore, do not connect the column to the pump before the apparatus is filled with liquids.

Fill the cups of the automatic sampler with samples and standard solutions. Sampling time is 90 seconds and rinsing time with water after each sample is 105 seconds. Start with the calibration solutions and run the calibration solution no. 1, 3, 5 and 6 between every tenth sample.

After analyses, run water through the system until all reagents are rinsed out. Turn off the recorder, photometer, sampler and pump, and loosen the tubings in the pump so they are not stretched.

Prepare a calibration curve by plotting the absorbances at 520 nm (each of the standard solutions against its concentration of nitrate).

4.3.2.7 Expression of results

Convert the recorder response (absorbance) of the sample to mg N/l by means of the calibration curves obtained just before or after the sample.

4.3.2.8 Interferences

Nitrite will interfere with the determination of nitrate.

4.3.2.9 References

Henriksen, A. and Selmer-Olsen, A.R. (1970) Automatic methods for determining nitrite in water and soil extracts. *Analyst*, 95, 514-518.

4.4 Determination of ammonium in precipitation

Ammonium may be determined together with the other major cations in precipitation if ion chromatograph equipment for cations is available. If not, the method described below is a good alternative.

4.4.1 Spectrophotometric by the indophenol blue method

4.4.1.1 Field of application

This method is applicable to the determination of the ammonium content in precipitation within the range 0.04 to 2.0 mg NH₄/l.

4.4.1.2 Principle

In an alkaline solution (pH 10.4-11.5) ammonium ions react with hypochlorite to form monochloramine. In the presence of phenol and an excess of hypochlorite, the monochloramine will form a blue coloured compound, indophenol, when nitroprusside is used as catalyst. The concentration of ammonium is determined spectrophotometrically at 630 nm.

4.4.1.3 Instrumentation

- Spectrophotometer
- Optical cell, 10 mm. If more than one cell is used, the cells should be matched photometrically
- Water bath with thermostat, 50 °C
- Test tubes: 30 ml
- Volumetric flasks: 10, 500 and 1000 ml
- Pipettes: 1.0, 2.0, 4.0, 5.0, 10.0, 20.0, 25.0, 50.0 ml.
- Micropipette: 250 µl

4.4.1.4 Chemicals

During analysis, use only chemicals of recognized analytical grade. The water used for dilution and rinsing should be double-distilled or de-ionized and distilled.

- Phenol (C₆H₅OH)
- Sodium nitroprusside (Na₂Fe(NO) (CN)₅ · 2H₂O)
- Sodium hydroxide (NaOH)
- Sodium hypochlorite solution (NaOCl) 1M:
- Make a solution containing approx. 3.5% active chlorine (35 g/l) in 0.1 M NaOH (e.g. British Drug House no. 23039)
- Ammonium chloride (NH₄Cl)
- Sodium thiosulphate (Na₂S₂O₃)

4.4.1.5 Reagents

- (1) Reagent A:
Dissolve 3.5 g phenol and 0.040 g sodium nitroprusside in 100 ml water. Store the solution refrigerated in the dark. If the colour of the solution turns greenish, it must be discarded, and a fresh solution prepared.
- (2) Reagent B:

Dissolve 1.8 g sodium hydroxide in some water in a 100 ml volumetric flask. Add 4.0 ml 1 M sodium hypochlorite solution, and dilute with water to the mark. Store the solution refrigerated in the dark. If the solution is stored for weeks, the concentration should be checked by titration with a sodium thiosulphate solution.

- (3) Standard ammonium solution I, 100 mg NH₄/l:
Ammonium chloride must be dried for one hour at 100 °C.
Dissolve 0.2965 g of the dried salt in water in a 1000 ml volumetric flask. Dilute to the mark with water. The solution is stable for six months when stored in a refrigerator.
- (4) Standard ammonium solution II, 4 mg NH₄/l:
By means of a pipette, transfer 20.0 ml of standard ammonium solution I to a 500 ml volumetric flask. Dilute with water to the mark. This standard ammonium solution, and the ammonium solutions made for preparing the calibration curve, must be freshly made.

4.4.1.6 Calibration

Preparation of calibration curve:

- (1) Transfer to 100 ml volumetric flask 0.0, 1.0, 2.0, 5.0, 10.0, 25.0 and 50.0 ml of standard ammonium solution II. Dilute to the mark with water. The concentrations of these solutions are 0.00, 0.04, 0.08, 0.2, 0.4, 1.0 and 2.0 mg NH₄/l. Transfer 5.0 ml of each of these standard solutions and 5.0 ml of water to a 30 ml test tube.
- (2) Add to the test tube 250 µl reagent A using a micro pipette, and mix well. Add then 250 µl reagent B using a micro-pipette and mix well. Cover the opening of the tube with some inert material. Place the tube in the water bath at 50 °C for two hours.
- (3) Cool the solution to room temperature, and transfer it to a 10 mm cell. Measure the absorbance at 630 nm.
- (4) Prepare a calibration curve by plotting the absorbance of each of the standard solutions against its concentration of ammonium. Prepare a new calibration curve for each series of samples.
- (5) In order to check for ammonium in the reagents, take a photometric reading of the blank (0.00 mg NH₄/l) against water. The absorbance should not exceed 0.020.

4.4.1.7 Analytical procedure

Transfer 5.0 ml of the sample and 5.0 ml of water to a 30 ml test tube. Proceed according to Section 4.4.1.6 (2) and (3). Convert the spectrophotometric readings of the sample to mg NH₄/l by means of the calibration curve. The concentration may be expressed as mg N/l by multiplying with 0.778. Samples containing more

than 2.0 mg NH₄/l must be diluted. With suitable equipment the "Indophenol method" can be made automatic. A detailed description is given in Section 4.4.2.

4.4.1.8 Interferences

Iron (III) may interfere if the concentration is more than 2 mg/l. This concentration of iron (III) does not occur very often in precipitation samples.

If the pH-value of the sample is lower than 3, the sample should be neutralized.

If the sample is turbid, both the sample and the blank should be filtered through a white band filter.

4.4.1.9 References

Koroleff, F. (1970) Direct determination of ammonia in natural waters as indophenol blue. In: *Information on Techniques and Methods for Seawater Analysis*. Charlottenlund, Internat. Counc. Exploration of the sea (Interlab. Rept. 3). pp. 19-22.

4.4.2 Automatic spectrophotometric determination of ammonium by the indophenol blue method

4.4.2.1 Field of application

This method can be used to determine the concentration of ammonium within the range 0.05 to 2.0 mg NH₄ /l.

4.4.2.2 Principle

The basic principles are the same as for the manual methods (see Section 4.4.1).

The reaction between ammonium and hypochlorite in an alkaline solution (pH: 10.5 to 11.5) gives monochloramine. In the presence of phenol and an excess of hypochlorite, the monochloramine will form a blue coloured compound, indophenol, when nitroprusside is used as catalyst. The concentration of ammonium in the solution is determined spectrophotometrically at 630 nm.

4.4.2.3 Instrumentation

- Peristaltic pump, 20-channels
- Automatic sampler with 4 ml cups
- 2 Photometers for measuring absorbance at 520 nm and 630 nm
- 2 recorders
- Oil bath with hermostat, 70° C
- Flexible tubings, connecting tubes, pulse suppressors, debubblers, mixing coils and reduction column (Figure 4.4.1).
- Pipettes: 50, 25, 20, 10, 5, 2.5 and 2 ml
- Analytical balance
- Desiccator

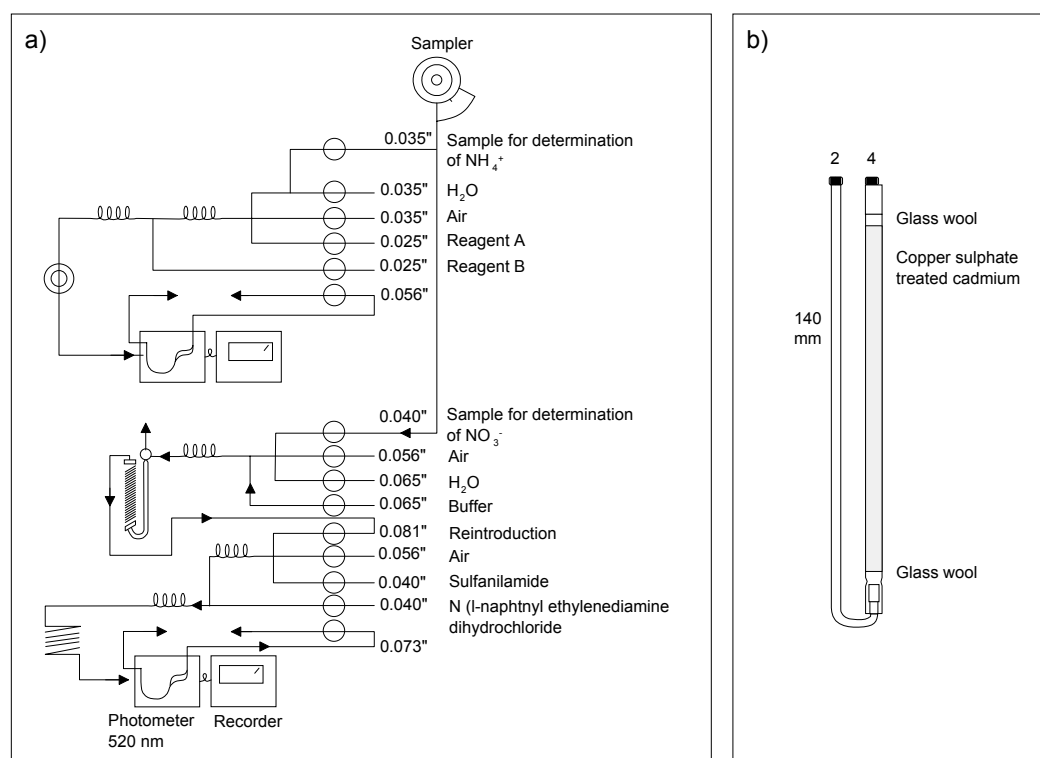

Figure 4.4.1: a) Automatic determination of nitrate and ammonium in precipitation samples.

b) Reduction column for the determination of nitrate in precipitation samples.

4.4.2.4 Chemicals

All chemicals must be of recognized analytical grade. The water used for dilution and rinsing must be double-distilled or deionized.

Potassium nitrate (KNO_3)

Phenol ($\text{C}_6\text{H}_5\text{OH}$)

Sodium nitroprusside ($\text{Na}_2\text{Fe}(\text{NO})(\text{CN})_5 \cdot 2\text{H}_2\text{O}$)

Sodium hydroxide (NaOH)

Sodium hypochlorite solution (NaOCl) 1M: Use a solution containing approximately 3.5% active chlorine (35g/l) in 0.1M NaOH (e.g. British Drug House, no. 23039)

Ammonium sulphate ($(\text{NH}_4)_2\text{SO}_4$)

Sodium thiosulphate ($\text{Na}_2\text{S}_2\text{O}_3$)

4.4.2.5 Reagents

Reagents for the determination of ammonium:

- (1) Dissolve 3.5 g phenol and 0.040 g sodium nitroprusside in 100 ml water. Store the solution refrigerated in the dark. If the colour of the solution turns greenish, a fresh solution must be prepared.

- (2) Dissolve 1.8 g sodium hydroxide in some water in a 100 ml volumetric flask. Add 4.0 ml hypochlorite solution and dilute with water to the mark. Store the solution refrigerated in the dark. If the solution is stored for weeks, it should be checked by titration with a sodium thiosulphate solution.

Dilute reagent (1) and reagent (2) with water 1:4 before use. These solutions must be prepared daily.

Standard solutions (for nitrate and ammonium):

- (3) Standard solution I, 500 mg NO₃/l and 200 mg NH₄/l:
Dry potassium nitrate and ammonium sulphate for 1 hour at 105 °C, and then cool for 20 minutes in a desiccator. Dissolve exactly 0.815 g potassium nitrate and exactly 0.735 g ammonium sulphate in water in a 1000 ml volumetric flask. Dilute to the mark with water. Store the solution refrigerated in the dark.
- (4) Standard solution II, 5.0 mg NO₃/l and 2.0 mg NH₄/l:
Dilute 5 ml of standard solution I (3) to 500 ml with water in a volumetric flask.

4.4.2.6 Calibration and analytical procedure

Prepare a series of calibration solutions according to Table 4.4.1.

Table 4.4.1: Calibration solutions for ammonium and nitrate.

Calibration solution No.	mg NO ₃ /l	mg NH ₄ /l	
1	5.0	2.0	Standard solution II
2	2.5	1.0	Dilute 100 ml of standard solution II to 200 ml with water
3	0.5	0.2	Dilute 20 ml of standard solution II to 200 ml with water
4	0.25	0.10	Dilute 10 ml of standard solution II to 200 ml with water
5	0.125	0.05	Dilute 5 ml of standard solution II to 200 ml with water
6	0.0	0.0	Water

These solutions may be stored in the refrigerator for a few days.

Start the pump and check the flow, all connections, tubings and debubblers with water running through the instrument. Turn on the photometers and the recorders (paper speed 10 mm/min.). Connect the tubings to the reagents and check that the baseline is stable.

Avoid air in the column containing the reducing agent. Therefore, do not connect the column to the pump before the apparatus is filled with liquids.

Fill the cups of the automatic sampler with samples and standard solutions. Sampling time is 90 seconds and rinsing time with water after each sample is 105 seconds. Start with the calibration solutions and run the calibration solution no. 1, 3, 5 and 6 between every tenth sample.

After analyses, run water through the system until all reagents are rinsed out. Turn off the recorder, photometer, sampler and pump, and loosen the tubings in the pump so they are not stretched.

Prepare a calibration curve by plotting the absorbances at 630 nm of each of the standard solutions against its concentration of ammonium.

4.4.2.7 Expression of results

Convert the recorder response (absorbance) of the sample to mg N/l by means of the calibration curves obtained just before or after the sample.

4.4.2.8 Interferences

Iron (III) ions may interfere with the determination of ammonium if the concentration is higher than 2 mg/l. This does not often occur in precipitation samples.

4.4.2.9 References

Harwood, J.E. and Huysen, D.J. (1970) Automated analysis of ammonia in water. *Water Res.*, 4, 695-704.

4.5 Determination of chloride in precipitation

When an ion chromatograph is not available, chloride may be determined spectrophotometric as described below.

4.5.1 Spectrophotometric mercury thiocyanate-iron method

4.5.1.1 Field of application

The method can be used for direct determination of the chloride ion content in precipitation samples within the range 0.05 to 5 mg/l.

4.5.1.2 Principle

Chloride ions will substitute the thiocyanate ions in undissociated mercury thiocyanate. The released thiocyanate ions react with ferric ions forming a dark red iron-thiocyanate complex.

The absorbance is measured at 460 nm.

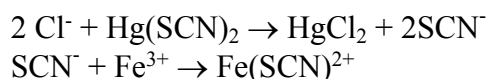

4.5.1.3 Instrumentation

- ◆ Spectrophotometer, equipped with 50 mm optical cells
- ◆ Pipettes
- ◆ Volumetric flasks
- ◆ Erlenmeyer flasks

4.5.1.4 Chemicals

During the analysis, use only chemicals of recognized analytical grade and only double-distilled or deionized and distilled water.

- ◆ Perchloric acid (HClO₄) 72%
- ◆ Mercury (II) (thiocyanate (Hg(SCN)₂))
- ◆ Iron (III) nitrate nonahydrate (Fe(NO₃)₃ · 9H₂O)
- ◆ Sodium chloride (NaCl)
- ◆ Ethanol (C₂H₅OH)

4.5.1.5 Reagents

- (1) Perchloric acid, 1:1
Mix 1 volume 72% perchloric acid with 1 volume of water.
- (2) Mercury (II) thiocyanate solution, saturated:
Shake 1 g Hg(SCN)₂ with 1000 ml ethanol. Filter the solution after 24 hours. The solution may be stored in a glass bottle at room temperature.
- (3) Iron (III) nitrate solution, 6%:
Dissolve 6 g Fe(NO₃)₃ · 9H₂O in 100 ml 1:1 perchloric acid. Filter the solution after 24 hours.

- (4) Standard chloride solution I, 1000 mg/l:
Dissolve 412.5 mg NaCl dried at 140-200 °C, in water and fill it up to 250 ml with water.
- (5) Standard chloride solution II, 10 mg/l:
Dilute 10.0 ml standard chloride solution I to 100 ml with water.

4.5.1.6 Calibration

Preparation of the calibration curve:

- (1) Transfer 2.5, 5.0, 7.5, 10, 15, 20 and 25 ml of standard chloride solution II to 50 ml volumetric flasks, and fill up to the mark with water. These solutions contain 0.5, 1.0, 1.5, 2.0, 3.0, 4.0 and 5.0 mg Cl/l.
- (2) Transfer 25 ml of the calibration solutions to 100 ml Erlenmeyer flasks. to each flask add with pipettes 5 ml mercury (II) thiocyanate solution and 2 ml iron (III) nitrate solution. Mix well between and after the additions. After 20 minutes, measure the absorbance in 50 mm cells at 460 nm.

As reference, use 25 ml water mixed well with 5 ml of reagent (2) and 2 ml of reagent (3).

Plot the readings against the concentrations and draw the calibration curve.

4.5.1.7 Analytical procedure

Transfer 25 ml of the precipitation sample to a 100 ml Erlenmeyer flask. Proceed according to 4.5.1.6 (2). Read the chloride content of the sample from the calibration curve.

4.5.1.8 Interferences

Bromide and iodide will give the same absorbance as the equivalent amount of chloride.

4.5.1.9 References

- Iwasaki, I., Utsumi, S., and Ozawa, T. (1952) New colorimetric determination of chloride using mercuric thiocyanate and ferric ion. *Bull. Chem. Soc. Japan*, 25, 226.
- Zall, M., Fisher, D., and Gamer, Q. (1956) Photometric determination of chlorides in water. *Anal. Chem.*, 28, 1665-1668.

4.6 Determination of sodium, potassium, magnesium, and calcium in precipitation

Sodium, potassium, magnesium, and calcium in precipitation can be analysed by atomic spectroscopic methods or with ion chromatography. Both flame (AAS and AES) and plasma (ICP-AES and ICP-MS) based methods can be used, but only the flame methods are described in this manual. For these ions ion chromatography have no special advantage concerning sensitivity, precision and accuracy over the spectroscopic methods, but analysis of all the ions in one run is not possible with flame AAS or AES.

4.6.1 Determination by flame atomic spectroscopy (AAS or AES)

4.6.1.1 Field of application

The method can normally be used for the determination of sodium, magnesium, potassium and calcium in precipitation within the range 0.01-2 mg/l, but this will depend to a certain degree on the commercial instruments used.

4.6.1.2 Principle

The ions in the sample solution are transformed to neutral atoms in an air/acetylene flame. Light from a hollow cathode or an electrodeless discharge (EDL)-lamp is passed through the flame. The light absorption of the atoms in the flame, which is proportional to the ion concentration in the sample, is measured by a detector following a monochromator set at the appropriate wavelength. The described principle holds for the measurement performed in the AAS-mode. In the AES-mode, the light emitted from the atoms exited in the flame is measured. Most commercial instruments can be run in both modes. Sodium may be measured more favorably in the emission mode.

4.6.1.3 Interferences

In atomic absorption spectroscopy both ionization- and chemical interferences may occur. These interferences are caused by other ions in the sample, and result in reduction of the number of neutral atoms in the flame. The ionization interference is avoided by adding a relative high amount of an easily ionized element to the samples and calibration solutions. For the determination of sodium and potassium, caesium is added. For the elimination of chemical interferences from e.g. aluminium and phosphate, lanthanum can be added to the samples and calibration solutions.

4.6.1.4 Instrumentation

Atomic absorption spectrophotometer with a digital readout, suitable recorder or a PC. The wavelength range must be 200-800 nm. Preferably the spectrophotometer should also have the possibility to be run in the emission mode.

EDL or hollow cathode lamps for Na, K, Mg and Ca. Single element lamps are preferred, but multi-element lamps may be used. EDLs are more intense than hollow cathode lamps, and is preferred for K and Na. When performing analyses in emission mode, no lamps are needed.

Pipettes and volumetric flasks in various sizes.

4.6.1.5 Chemicals

- Deionized water
- Hydrochloric acid (HCl), suprapur, 37%
- Caesium chloride (CsCl), suprapur or Cs-solution specially produced for AAS
- Lanthanum oxide (La₂O₃), 99.99% or La-solution specially produced for AAS
- Sodium chloride (NaCl), spectrapure
- Potassium chloride (KCl), spectrapure
- Magnesium oxide (MgO), spectrapure
- Calcium carbonate (CaCO₃), spectrapure

Compressed gas and pressure-reducing valves. Both acetylene and air are needed. The air may be supplied from a compressor with a cleaning unit.

4.6.1.6 Reagents

Caesium-Lanthanum-solution, 100.000 mg Cs/l + 50.000 mg La/l

Transfer 5,865 g La₂O₃ and 12,67 g CsCl to a 100 ml volumetric flask. Add about 50 ml deionized water and 25 ml suprapure HCl, and dilute to the mark with deionized water.

Commercial available solutions specially produced for AAS may be used.

It is very important that the caesium and lanthanum-solutions used have a low content of sodium, potassium, magnesium and calcium since a relative high concentration of this solution is added to the sample.

4.6.1.7 Calibration solutions and stock solutions

Na, 1000 mg/l:

Transfer 2,542 g NaCl, dried at 140 °C for 1 hour before weighing, to a 1000 ml volumetric flask, add 50 ml of deionized water and 1 ml HCl and shake until all is dissolved. Dilute to the mark with deionized water. Store the solution in a polyethylene bottle.

K, 1000 mg/l:

Transfer 1,907 g KCl, dried at 110 °C for 1 hour before weighing, to a 1000 ml volumetric flask. Add 50 ml of deionized water and 1 ml HCl and shake until all is dissolved. Dilute to the mark with deionized water. Store the solution in a polyethylene bottle.

Mg, 1000 mg/l:

Transfer 1,658 g MgO to a 1000 ml volumetric flask. Add 10 ml HCl and shake until all is dissolved. Dilute to the mark with deionized water. Store the solution in a polyethylene bottle.

Ca, 1000 mg/l:

Transfer 2,497 g CaCO₃, dried at 180 °C for 1 hour before weighting, to a 1000 ml volumetric flask. Add 50 ml of deionized water, and dissolve slowly with a minimum of HCl. Dilute to the mark with deionized water. Store the solution in a polyethylene bottle.

Working standard solution, Na, K, Mg and Ca 10 mg/l:

Pipette 10,0 ml of each of the stock solutions Na, K, Mg, and Ca 1000 mg/l to a 1000 ml volumetric flask. Dilute to the mark with deionized water. Store the solution in a polyethylene bottle. The solution should be made fresh each time the calibration solutions are prepared.

Calibration solutions for Na, K, Mg and Ca:

Pipette 1, 2, 5, 10, 15, 20, 40, and 50 ml of the working standard solution, 10 mg/l to each of eight 100 ml volumetric flasks. Add 1 ml of the Cs-La-solution and dilute to the mark with deionized water. The concentrations in the solutions will be 0,1, 0,2, 0,5, 1,0, 1,5, 2,0, 4,0 and 5,0 mg/l respectively. A solution with 1 ml Cs-La- solution diluted to 100 ml is used as a blank.

The calibration solutions and the blank should be stored in polyethylene bottles and made fresh the day of analysis.

4.6.1.8 Calibration of the instrument

After a warm-up time of the instrument, set the wavelength for the element to be analysed as given in Table 4.6.1, and the slit width and the air/acetylene ratio as given in the instruction manual for the instrument. Ignite the flame. Adjust the reading of the instrument to zero by spraying the blank into the flame. Run the calibration solutions and read the absorption (or emission) signals from the readout. Plot the calibration graph.

The instrument should be recalibrated after every 20-30 samples. A control solution should also be run after each calibration.

Table 4.6.1: Wavelength settings for the analyses.

Element	Sodium	Potassium	Magnesium	Calcium
Wavelength nm	589.6	766.5	285.5	422.7

4.6.1.9 Analytical procedure

Transfer 10 ml of the sample to a test tube. Add with a micro pipette 100 µl of the Cs-La solution and mix well. Run the samples and read the absorption (or emission) signal from the readout. Use the calibration graph to find the concentration in the sample.

Note: Read and follow the instructions for the instrument carefully.

4.7 Determination of pH in precipitation

4.7.1 Potentiometric method

4.7.1.1 Principle

The method is based on the determination of the potential difference between an electrode pair consisting of a glass electrode sensitive to the difference in the hydrogen ion activity in the sample solution and the internal filling solution, and a reference electrode, which is supposed to have a constant potential independent of the immersing solution. The measured potential difference is compared with the potential obtained when both electrodes are immersed in a solution or buffer with known pH or hydrogen ion concentration. The pH is defined by the formula:

$$\text{pH}_{(\text{sample})} = \text{pH}_{(\text{reference})} + (E_{(\text{sample})} - E_{(\text{reference})}) F/RT \ln 10$$

where E are the electrode potentials, R is the universal gas constant, T the absolute temperature and F is the Faraday constant.

This is an operationally defined pH. Buffers of known pH are specified by National Bureau of Standards, now the National Institute of Standardized Technology (NIST). The primary standard and the most widely used buffer for pH-meter calibration is 0.05 M potassium hydrogen phthalate, which has a pH of 4.00 at 20° C, and a hydrogen ion activity of 10^{-4} M. This latter hydrogen ion activity is based on theoretical calculations (the Bates-Guggenheim convention).

In precipitation samples, the ionic strength will typically be in the region 10^{-3} to 10^{-5} . The activity coefficient for monovalent cations such as the hydrogen ion will therefore be in the range 0.95-0.99. This corresponds to <0.02 pH-units difference between pH and $-\log(\text{H}^+)$. Much more critical is the assumption of a constant reference electrode potential when going from a relatively concentrated potassium hydrogen phthalate solution to extremely dilute precipitations samples. The problem arises because of the inherent possibility of building up a liquid junction potential between the internal solution of the reference electrode, and the sample solution. This liquid junction potential may be larger if the ionic strength difference between the two solutions is large. It is reduced by making the boundary between the concentrated filling solution and the sample as sharp as possible. Various designs of pH cells meeting this criterion have been proposed. Tests of commercial electrodes against dilute acid solutions and low ionic strength buffers with known pH or hydrogen ion concentrations have shown, however, that this problem has largely been overcome with modern pH instrumentation and electrode systems.

However, it is strongly recommended to check the electrode system at regular intervals, by measuring the “apparent pH” of a solution with low ionic strength with known pH or hydrogen ion concentration. The pH readings should be within 0.02 or 0.05 pH-units of the “theoretical” result. If this is not the case, or if the reading is unstable during stirring of the solution, the reference electrode should be replaced. New glass electrodes should be tested against at least two buffers to see that the response is Nernstian.

The reference electrode should preferably be stored in dilute potassium chloride solution (0.1M).

4.7.1.2 Instrumentation

pH-meter with the possibility of reading to the nearest 0.02 pH-units or preferably to the nearest 0.01 pH-unit.

A glass electrode and a reference electrode must be used with the pH-meter. The reference electrode should be suitable for measurement in low-ionic strength solutions and preferably be of the calomel type filled with saturated potassium chloride. Other reference electrodes or combination electrodes may be used, but all electrodes should be checked for acceptable performance.

Magnetic stirrer, with teflon coated stirring bar.

Beakers used for the test solution should be made of borosilicate glass or polyethylene.

4.7.1.3 Chemicals

Buffer solutions for the calibration of the pH-meter. Preferably the two buffer solutions given in Section 4.7.1.4, which are recommended as standards by the U.S. National Institute of Standards and Technology (NIST).

4.7.1.4 Reagents

National Bureau of Standards solutions with known pH.

- (1) 0.05 M potassium hydrogen phthalate ($C_6H_4(COOH)(COOK)$)
pH = 4.00 at 20 °C
pH = 4.01 at 25 °C

Dissolve 10.12 g potassium hydrogen phthalate, $C_6H_4(COOH)(COOK)$, dried at 120 °C, in 1000 ml distilled water.

- (2) 0.025 M potassium dihydrogen phosphate (KH_2PO_4) and 0.025 M disodium hydrogen phosphate (Na_2HPO_4)
pH = 6.88 at 20 °C
pH = 6.86 at 25 °C

Dissolve 3.39 g potassium dihydrogen phosphate, KH_2PO_4 , and 3.53 g disodium hydrogen phosphate, Na_2HPO_4 , dried at 120° C, in 1000 ml distilled water. Instead of the anhydrous disodium hydrogen phosphate, 4.43 g of undried dihydrate, $Na_2HPO_4 \cdot 2 H_2O$, may be used.

Commercial available buffer solutions may also be used, but should be checked against the primary standard buffers described above. The buffers should be kept in the dark in well closed bottles of borosilicate or polyethylene.

4.7.1.5 Calibration

Calibrate the pH-meter according to the instruction manual for the instrument using one, or preferably two, buffer solutions. The temperature of the buffer solutions must be known. The calibration should be checked after each set of samples.

4.7.1.6 Analytical procedure

Measure the pH-value of the sample according to the instruction manual for the instrument. The solution may be stirred, but not vigorously. The temperature of the sample solution must be the same as the temperature of the buffer solution used for calibration.

Rinse the electrodes thoroughly with distilled water between each measurement, and wipe off the excess water with a soft paper.

Store the electrodes in 0.1 M KCl-solution or according to the manufacturers recommendations. The reference electrode should not be stored in distilled water!

4.7.1.7 Performance test of the electrode pair

As mentioned in Section 4.7.1.1 the behaviour of the reference electrode is the main source of errors in pH-measurements, especially in low ionic strength solutions. In order to check the performance of the reference electrode, control measurements should be made on solutions of dilute acids or dilute buffers to verify that correct values are obtained for solutions of lower ionic strengths. A solution which should give a pH ~4.00 could be used for the test. A 10^{-4} M HCl-solution should give a pH of 3.99 ± 0.05 .

Electrode pairs should also show minimal differences between measurements made in stirred and unstirred low ionic strength solutions.

Usually the liquid junction between the solution and the saturated KCl-solution in the reference electrode is formed in a porous plug of ceramic fibre. Slow stirring removes the concentrated KCl-solution which slowly runs out through this capillary.

If the stirring is too vigorous, the ionic medium in the plug itself may be diluted. This will increase the liquid junction potential, and should be avoided. The liquid junction potential may also increase if the porous plug is clogged up by impurities.

4.7.2 References

Bates, R.G. (1965) Determination of pH, theory and practice. New York, Wiley.

Linnet, N. (1970) pH measurements in theory and practice. Copenhagen, Radiometer.

Westcott, C.C. (1978) pH measurement. New York, Acad. Press.

Davison, W. and Woof, C. (1985) Performance tests for the measurement of pH with glass electrodes in low ionic strength solutions including natural waters. *Anal. Chem.*, 57, 2567-2570.

4.8 Determination of strong and weak acids in precipitation

4.8.1 Coulometric titration method

4.8.1.1 Field of application

This method is applicable to determination of strong acids in precipitation samples within the concentration range 10^{-5} to 10^{-3} M. Higher concentrations of acidity are not expected in precipitation. The lower concentration limit is close to the concentrations at background sites without alkaline mineral dust.

4.8.1.2 Principle

In the coulometric titration method (Liberti et al., 1972), the acid is titrated at constant current with hydroxyl ions liberated at a platinum electrode, a silver-silver bromide electrode serving as the counter electrode. The overall reaction is:

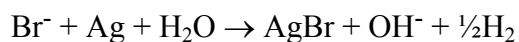

The emf of a glass-calomel electrode pair is read at intervals and the results are used to construct a Gran's plot (Gran, 1952; Rosotti and Rosotti, 1965), which gives the endpoint of the titration by extrapolation of the straight part of the curve.

The only necessary modification is the addition of a constant, known amount of acid to the sample before the titration, in order to facilitate the titration of weakly acidic or alkaline samples without interference from carbon dioxide.

4.8.1.3 Instrumentation

- Expanded-scale pH-meter (Radiometer PHM 26 or an instrument with similar specifications).
- Constant current source (2-10 mA adjustable)
- A 4.5 V dry battery with an adjustable series resistance and a mA meter is sufficient for measurements, but "coulometers" are available commercially (e.g. Metrohm).
- Titration vessel, 100 ml
This should have a suitable lid with holes to serve as support for the electrodes and the nitrogen inlet, and be supplied with a thermostat jacket.
- Thermostat ($25\text{ }^\circ\text{C} \pm 1\text{ }^\circ\text{C}$)
- Sensing electrodes
An ordinary glass electrode (pH range 0-10) and a calomel reference electrode, or a combined electrode.
- Working electrodes
The platinum electrode ($2 \times 2\text{ cm}^2$) is made of bright platinum (sheet or net).
The silver electrode is made from 99.9% pure silver, 1.0 mm dia. wire, about 30 cm long and coiled to a suitable dimension.
- Pipette : 50 ml
- Micro pipettes : 0.5, 1.0 ml
- Volumetric flask : 1000 ml

4.8.1.4 Chemicals and reagents

During analysis, use only reagents of recognized analytical grade. The water used for dilution and rinsing must be double-distilled or de-ionized and distilled.

Nitrogen gas (N₂) 99.9%
 Potassium bromide (KBr)
 Sulphuric acid (H₂SO₄) 0.05M
 Buffer solution pH = 4.00

Solution I: 1 M KBr and 2.5 · 10⁻³ M H₂SO₄
 Transfer 120.0 g KBr and exactly 50 ml of 0.05M H₂SO₄ to a 1000 ml volumetric flask. Fill up to the mark with water.

4.8.1.5 Analytical procedure

Turn on all instruments, and allow heating for ½ hour. Adjust the pH-meter to pH = 4.00, using the buffer solution. Transfer 50 ml of the sample into the thermostated titration vessel, and add 1 ml of solution I. Start nitrogen purging and adjust flow to give continuous agitation of the solution. The bubbles should not disturb the solution between the sensing and the working electrodes. Measure the pH of the solution. If the pH of the sample is above 5.6 it may be necessary to add more than 1 ml of solution I.

Wait until pH reading is constant. Switch pH-meter to read millivolts (range 0-240 mV with glass electrode positive) and start the electrolysis current.

Read the glass electrode potential vs the calomel electrode every 20 seconds and continue until the potential changes sign (at pH ca. 8). Stop the electrolysis.

Plot Gran's function, Ψ , at 25°C, see Table 4.8.1 against electrolysis time (in seconds). The plot intercepts the abscissa at the equivalence point, t_e (F = Faradays constant, R = the universal gas constant, T = absolute temperature).

$$\psi = 10^{\frac{EF}{RT \ln 10}}$$

$$\psi = 10^{\frac{E}{59.15}} \text{ at } 25^\circ\text{C}$$

Table 4.8.1: Gran's function.

E_{mV}	ψ	E_{mV}	ψ	E_{mV}	ψ	E_{mV}	ψ
1	1.04	41	4.93	81	23.4	121	111
2	1.08	42	5.13	82	24.4	122	115
3	1.14	43	5.33	83	25.3	123	120
4	1.17	44	5.55	84	26.3	124	125
5	1.22	45	5.77	85	27.4	125	130
6	1.26	46	5.98	86	28.4	126	135
7	1.31	47	6.22	87	29.6	127	140
8	1.36	48	6.47	88	30.7	128	146
9	1.42	49	6.75	89	32.0	129	152
10	1.48	50	7.00	90	33.3	130	158
11	1.54	51	7.28	91	34.6	131	164
12	1.60	52	7.57	92	36.0	132	171
13	1.66	53	7.87	93	37.4	133	177
14	1.73	54	8.19	94	38.8	134	185
15	1.80	55	8.51	95	40.4	135	192
16	1.90	56	8.85	96	42.0	136	199
17	1.94	57	9.20	97	43.6	137	207
18	2.02	58	9.57	98	45.3	138	216
19	2.10	59	9.94	99	47.2	139	224
20	2.18	60	10.3	100	49.1	140	233
21	2.26	61	10.7	101	51.0	141	242
22	2.36	62	11.1	102	53.1	142	252
23	2.45	63	11.6	103	55.2	143	262
24	2.54	64	12.1	104	57.4	144	272
25	2.65	65	12.5	105	59.7	145	283
26	2.75	66	13.0	106	61.9	146	294
27	2.86	67	13.5	107	64.4	147	306
28	2.97	68	14.1	108	67.0	148	318
29	3.09	69	14.6	109	69.7	149	331
30	3.21	70	15.2	110	72.4	150	344
31	3.34	71	15.8	111	75.3	151	351
32	3.48	72	16.5	112	78.3	152	371
34	3.61	74	17.1	113	81.5	153	386
34	3.75	74	17.8	114	84.7	154	402
35	3.90	75	18.5	115	88.1	155	418
36	4.06	76	19.3	116	91.6	156	434
37	4.23	77	20.0	117	95.1	157	452
38	4.39	78	20.8	118	98.9	158	470
39	4.56	79	21.7	119	103	159	489
40	4.74	80	22.5	120	106	160	507

4.8.1.6 Expression of results

The concentration of strong acid in the sample is calculated from the formula:

$$C_{H^+} = \frac{i \cdot t_e}{F \cdot V_o} - \frac{N_{H_2SO_4} \cdot V_{H_2SO_4}}{V_o}$$

or

$$C_{H^+} = \frac{i \cdot t_e \cdot 1000}{96\,500 \cdot 50} - 1 \cdot 10^{-4} \text{ moles/l}$$

where

i	=	electrolysis current in ampères
t _e	=	electrolysis time at equivalence point (seconds)
F	=	Faradays constant (coulombs/mol)
V _o	=	initial sample volume (litres)
N _{H₂SO₄}	=	normality of added sulphuric acid
V _{H₂SO₄}	=	volume of added sulphuric acid (litres)

Notes:

Borosilicate glass can be used for storage of samples.

The glassware must be treated with hot dilute acid and thoroughly soaked in distilled water prior to use. 12 hours with 10% hydrochloric acid at 90°C followed by 24 hours soaking in distilled water is considered adequate. Otherwise, alkali metals from the glass will diffuse into the samples.

Equipment for the automatic plotting of Gran's function is available. The equipment is described in Section 4.8.2.

4.8.1.7 References

Gran, G. (1952) Determination of the equivalence point in potentiometric titrations. Part II. *Analyst*, 77, 661-671.

Liberti, A., Possanzini, M. and Vicedomini, M. (1972) The determination of the non-volatile acidity of rain water by a coulometric procedure. *Analyst*, 97, 352-356.

Rosotti, F.J.C. and Rosotti, H.J. (1965) Potentiometric titrations using Gran's plots. *Chem. Educ.*, 42, 375-378.

4.8.2 *Coulometric titration of strong acid by means of an instrument for automatic plotting of Gran's function*

4.8.2.1 *Field of application*

This automatic method can be used to determine the concentration of hydrogen ions in precipitation within the range 10^{-5} to 10^{-3} M.

4.8.2.2 *Principle*

The basic principle is the same as for the manual method described in Section 4.8.1.

In the present method, the pH is continuously monitored by feeding the output from the pH-meter into an instrument for automatic plotting of the Gran's function (APGRAF), which gives a recorder output from 1.0 mV at pH 7 to 10 V at pH 3. This signal is thus proportional to the hydrogen ion concentration in the solution. Since the volume of the solution is not altered during the coulometric titration, and the hydroxyl ions are supplied at a constant rate, the recorder output gives the Gran's function directly.

The APGRAF consists of two amplifiers and a current source capable of delivering a constant current for coulometric titration ranging from 3.5 to 7.5 mA. The range can be extended to maximum 20 mA. The APGRAF is designed to work with the pH-meter RADIOMETER PHM 26c.

4.8.2.3 *Instrumentation*

- Expanded scale pH-meter (RADIOMETER PHM 26c or instrument with equal specifications).
- Constant current source (2-10 mA adjustable).
- Instrument for automatic plotting of Gran's function (APGRAF, see below)
- Thermostated titration vessel, 100 ml, equipped with a lid with holes for electrodes and nitrogen inlet.
- Thermostat ($25^{\circ} \pm 1^{\circ}\text{C}$).
- Sensing electrodes: Glass electrode (pH range 0 to 10) and calomel electrode, or a combined electrode.
- Working electrodes: Platinum electrode, sheet or net ($2 \times 2 \text{ cm}^2$) made of bright platinum. Silver electrode made of 99.9% silver wire 30 cm long and 1.0 mm diameter, coiled to suitable dimensions.
- Volumetric flask, borosilicate glass 1000 ml.
- Pipettes : 25 ml, 50 ml.
- Micro pipettes : 0.5 ml, 1.0 ml.
- Recorder.

Construction of the APGRAF

Figure 4.8.1 shows a block diagram of the layout, and a complete wiring diagram is shown in Figure 4.8.2. The 10 mV/pH output from the pH-meter is used as input signal to the preamplifier A1. The latter is adjusted to a gain of 1000 mV pH^{-1} and balanced to +2.0 V at pH 7 and -1.0 V at pH 4. The log amplifier A2 has

an output of 1 decade per volt input, connected in the antilog of voltage mode, i.e. +10V out for a -2V input and +10 mV for a +1V input.

The gain is adjusted by the 5 k Ω input resistor (potentiometer). The balance is adjusted by the 100 Ω potentiometer connected via 10 k Ω to pin 3 on A1. The ZF 5.6 zener is used to stabilize “Balance” versus temperature changes.

Amplifier A3 is a unity gain, non-inverting amplifier providing a low source resistance for amplifier A4 (current source). A4 supplies a current that is proportional to the input voltage, but the output polarity is reversed.

The desired current is set by selecting one of the outputs of the voltage divider which is fed into A3.

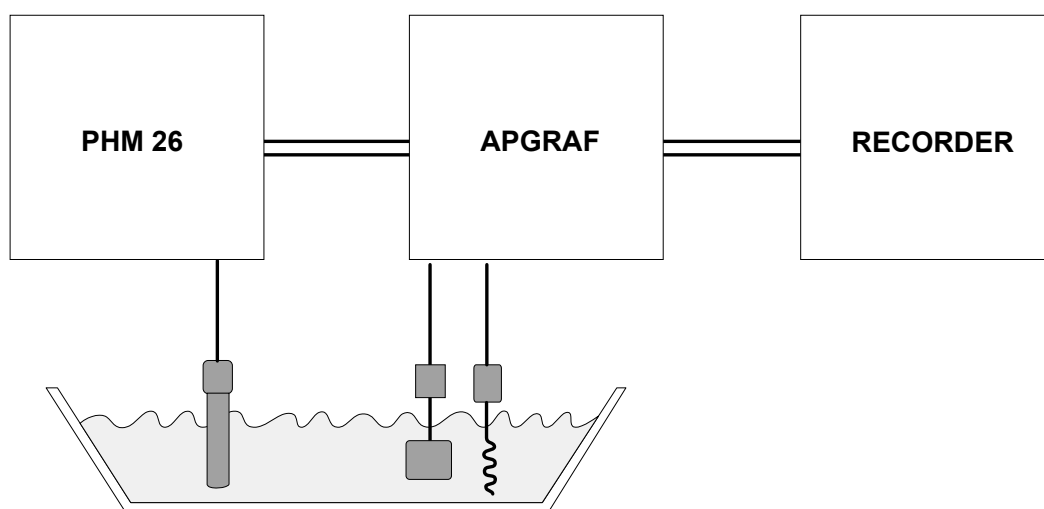

Figure 4.8.1: Instrumental layout for automatic plotting of Gran's function.

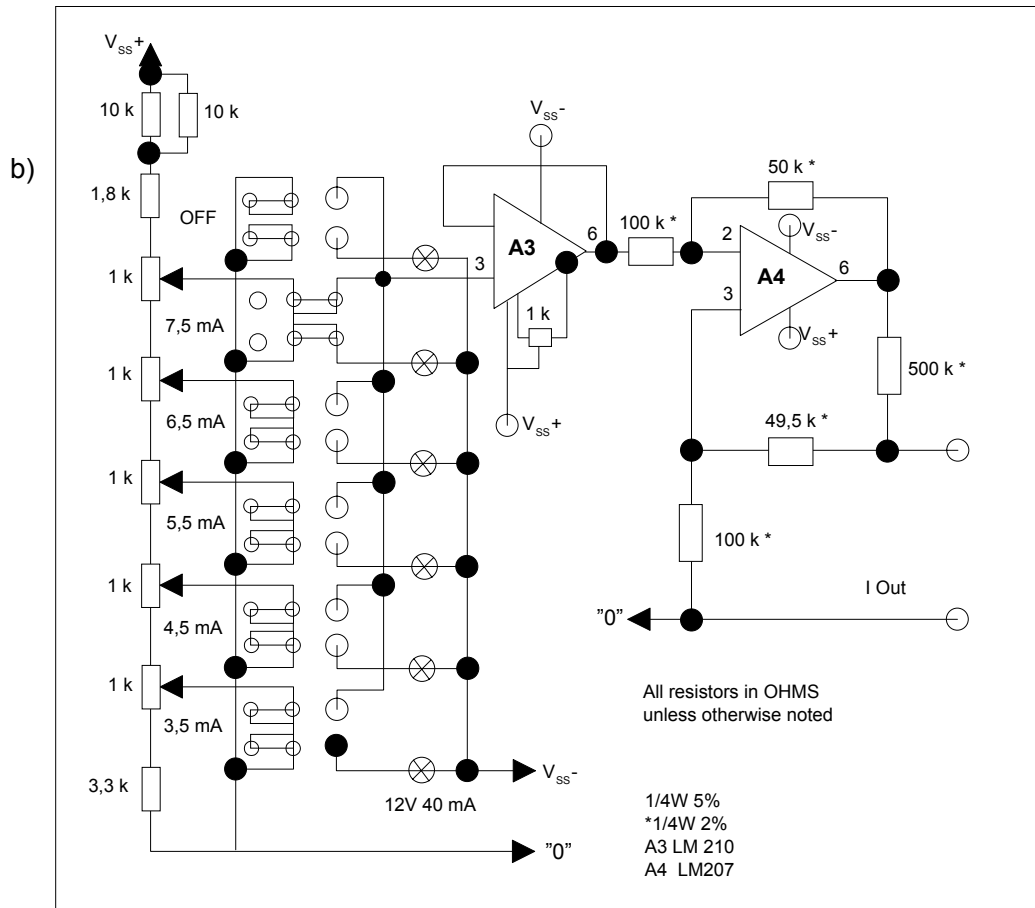
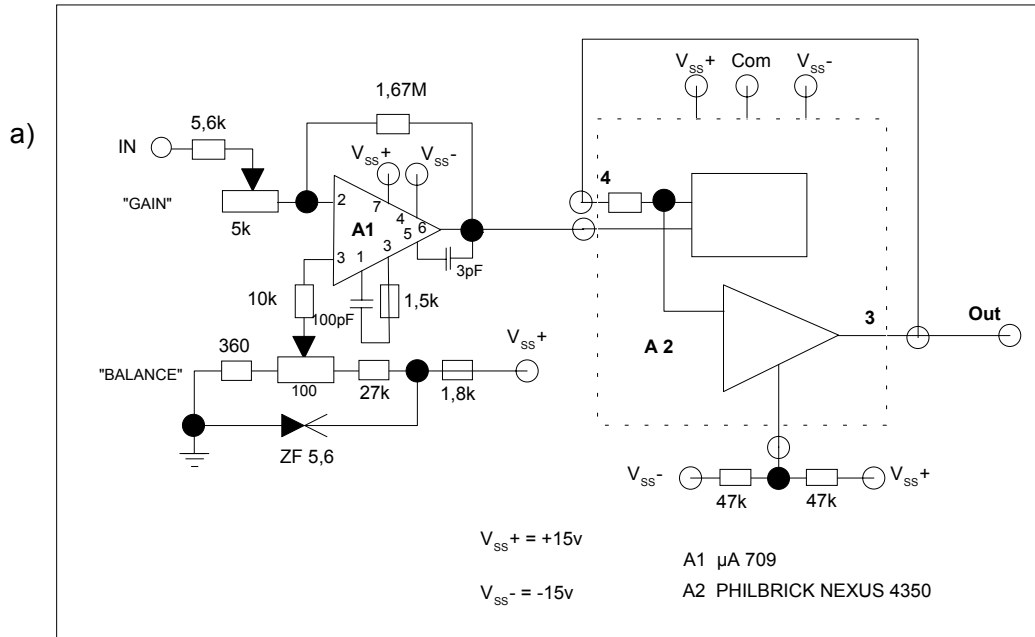

Figure 4.8.2: Wiring diagrams of a) amplifier and b) constant current source of the APGRAF (7.5 mA selected).

4.8.2.4 Chemicals and reagents

Use only reagents of recognized analytical grade. The water must be double-distilled or deionized and distilled.

- Potassium bromide (KBr)
- Sulphuric acid 0.05 M (H₂SO₄)
- Nitrogen 99.9% (N₂)

Solution I: 1M KBr and $2.5 \cdot 10^{-3}$ M H₂SO₄:

Transfer 120.0 g KBr and exactly 50 ml 0.05 M H₂SO₄ to a 1000 ml volumetric flask. Fill up to the mark with water.

4.8.2.5 Calibration

- (1) Connect the APGRAF to the pH-meter.
- (2) Place the calomel electrode in a buffer solution with pH 4.
- (3) Let the output from the preamplifier (A1) stabilize.
- (4) Read the output voltage from the preamplifier.
- (5) Adjust the output to approximately -1.0V
- (6) Recheck pH and preamplifier output, note the values.
- (9) Check gain.

Example:	pH 4.0	output -0.900 V
	pH 7.0	output +2.230 V
Difference	pH 3.0	Difference output 3.130 V

$$\frac{3130 \text{ mV}}{3 \text{ pH - units}} = 1043 \text{ mV / pH - unit}$$

This should be adjusted to 1000 mV/pH-unit.

Try a couple of clockwise turns on “gain” potentiometer.

Repeat the procedure 1 through 9.

“Gain” and “Balance” interact. If gain is correctly set and balance has to be changed, recheck gain and readjust if necessary (“tracking”).

4.8.2.6 Analytical procedure

Turn on all instruments, and allow 30 minutes warm-up. Adjust the pH-meter to pH = 4.00, using the buffer solution. Transfer 50 ml of the sample into the thermostated titration vessel, and add 1 ml of solution I. Start nitrogen purging and adjust flow to give continuous agitation of the solution. The bubbles should not disturb the solution between the sensing and the working electrodes. Measure the pH of the solution. If the pH of the sample is still above 4.0 add more of solution I until the pH is less than 4.0.

Switch the pH-meter to the mV position, and turn on the recorder (paper speed 1 mm/sec). Select the electrolysis current (3-5 mA) and start the titration. This

will result in a “jump” on the recorder trace, because the electrode potential is affected by the potential between the working electrodes. Minimize this effect by proper positioning of the electrodes. Mark the starting point on the paper. Continue the electrolysis until the recorder signal is zero (baseline). Stop the electrolysis and the recorder. Note the sample identification, electrolysis current, and the amount of acid (solution I) added, on the recorder sheet.

4.8.2.7 Expression of results

Draw a vertical line from the starting point on the paper, to the baseline. Extrapolate the first straight part of the titration curve until it reaches the baseline, see Figure 4.8.3. (The curve is usually not a straight line at the end of the titration.) Measure the distance (mm) along the baseline between these two points (l).

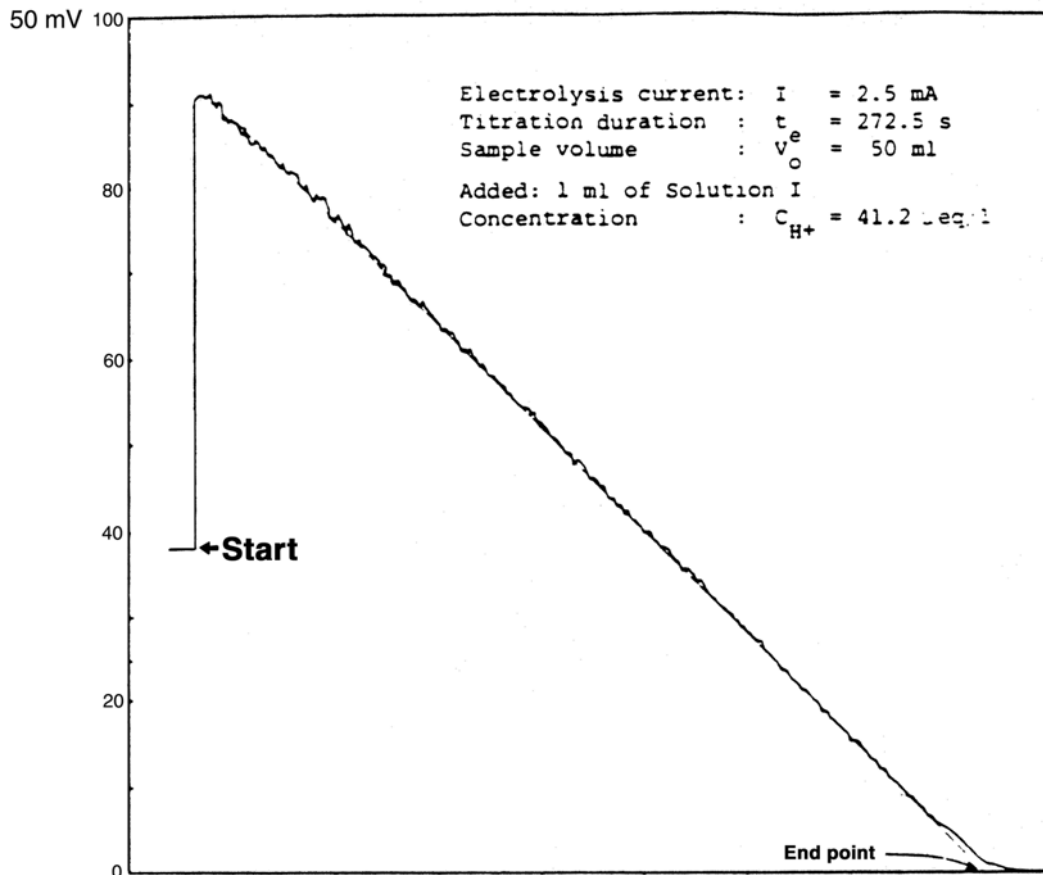

Figure 4.8.3: Titration graph for an actual precipitation sample.

The concentration of strong acid (in moles/litre) is calculated from:

$$C_{H^+} = \frac{1000 \cdot i \cdot t_e}{F \cdot V_o} - \frac{N_{H_2SO_4} \cdot V_{H_2SO_4}}{V_o}$$

where

i	=	electrolysis current (A)
t_e	=	duration of analysis (s), determined from the distance between the start of titration and the end point on the chart, and the paper chart speed.
F	=	Faraday constant (96500 C/mol)
V_o	=	sample volume (ml), normally 50 ml
$N_{H_2SO_4}$	=	normality of added sulphuric acid
$V_{H_2SO_4}$	=	volume (ml) of added sulphuric acid

4.9 Determination of conductivity

The conductivity of precipitation samples depends on the concentrations of the various ion species and their different ability to transport electric charges in a solution, i.e. the ion species equivalent conductivity. This conductivity is temperature dependent and increases approximately 2% per degree in aqueous solutions for most ion species. Conductivity measurements can through comparison with estimated conductivity and in combination with ion balance calculations and records of old data help identify ion concentrations which are wrong or inaccurate.

4.9.1 Principle

Conductance is the inverse of resistance in a solution and the conductivity the inverse of specific resistance. Conductivity is measured with a bridge and a measuring cell, and it is dependent upon distance between the electrodes and their area, in the measurement cell. This is expressed by the cell constant which is a characteristic of the measurement cell. The resistance, R , can be expressed as

$$R = \rho \frac{l}{A}$$

where l is distance between the electrodes and A their area. ρ is the specific resistivity. The specific conductance, or conductivity κ is

$$\kappa = \frac{l}{\rho} \text{ or } \frac{l}{R} \cdot \frac{l}{A}$$

where $\frac{l}{A}$ is the cell constant.

4.9.2 Instrumentation

The conductivity meter applied should have a measurement range 1–1000 $\mu\text{S}/\text{cm}$, a precision within this range of 0.5% and an accuracy within 1%. Conductivity meters may be able to give the result at a pre-selected reference temperature while the actual measurement is carried out at room temperature. Other meters need a waterbath for the measurement cell in order to give a result at 25 °C, which is the temperature used for EMEP's and WMO GAW's conductivity measurements. Besides the conductivity meter itself, a platinum conductivity cell is needed, and possibly a water bath and a thermometer.

4.9.3 Chemicals

- Deionized water, conductivity < 0.5 $\mu\text{S}/\text{cm}$
- Potassium chloride p.a. quality

4.9.4 Calibration solutions

0.1M KCl stock solution

Transfer 7.4560 g KCl, dried at least 2 hours at 110°C, to a volumetric flask and dilute to 1000.0 ml with deionized water. The solution should be transferred to a plastic flask. The stability of the solution is one year at most.

A series of calibration solutions based on the 0.1 M KCl stock solution is used for the calibration procedure, as seen from Table 4.9.1. The solutions should be kept well closed in plastic flasks at room temperature. The stability is 6 months at most.

Table 4.9.1: Calibration standards for conductivity at 25°C.

Concentration M KCl	Conductivity $\mu\text{S/cm}$	Upper limit $\mu\text{S/cm}$	Lower limit $\mu\text{S/cm}$
0.0500	6668	6801	6535
0.0200	2767	2822	2711
0.0100	1413	1441	1395
0.0050	717.8	735	700
0.0010	147.0	149	145
0.0005	73.9	77.8	70.2
0.0001	14.94	16.5	13.5

4.9.5 Calibration of the instrument

Calibration of the cell constant

The cell constant should be calibrated whenever the conductivity of the 0.0010 M KCl calibration solution is outside the upper and lower limits given in Table 4.9.1. The age of the calibration solution must be checked before the calibration. Enter the new constant after having followed the cell constant calibration procedure given in the instrument manual. Reference temperature (or measurement temperature) should be 25°C.

Calibration with calibration solutions

Before running a series of precipitation samples, measurements should be carried out with the 0.0001, 0.001 and 0.0100 M KCl calibration solutions. Check the age of the calibration solutions. If the measurements are outside the limits given in Table 4.9.1 the instrument must be checked as specified in the manufacturers instrument manual followed by measurements with all calibration solutions in Table 4.9.1. Reference temperature should be 25°C. Results obtained at other temperatures can be corrected to 25°C as seen in the next Section.

4.9.6 Measurement procedure

The procedure given in the instrument manual must be followed. In general the measurement cell has to be rinsed well with deionized water, dried with a Kleenex, and rinsed again with the measurement solution a few times before a correct reading can be made. The display will also need some time to stabilize

before the reading. The reference temperature should be 25°C, and the result expressed in $\mu\text{S}/\text{cm}$. If the measurement is carried out at a different temperature, the result should be corrected to 25°C. The temperature coefficient for aqueous solutions is approximately 2% pr. degree. The formula below will give the conductivity, κ_{25} , corrected to 25°C when the measurement l_t is carried out at a temperature t .

$$\kappa_{25} = \frac{\kappa}{(1.0 + 0.02(t - 25))}$$

4.9.7 Maintenance and storage of measurement cell

It is essential that the manufacturers instructions are followed. Cleaning of the measurement cell is needed if a contamination is discovered.

4.10 Determination of sulphur dioxide as sulphate ions on impregnated filters

The extraction of sulphate from the alkaline impregnated filters is described in Section 3.6. For the Thorin method the extract has a too high pH to permit a direct analysis and the solution has to be treated with a cation resin before analysis.

4.10.1 Determination of sulphur dioxide as sulphate by ion chromatography

The procedure after the extraction from the filter (Section 3.6) for Dionex systems and Waters systems are described in Section 4.1.

4.10.2 Determination of sulphur dioxide as sulphate spectrophotometric by the barium perchlorate – Thorin method

4.10.2.1 Field of application

This method can be used for the determination of sulphur dioxide in ambient air after the sulphur dioxide has been absorbed on a potassium hydroxide impregnated filter (see Section 3.6). The concentration range is 0.1 to 8 mg SO₂ per litre leaching solution.

4.10.2.2 Principle

Sulphur dioxide is absorbed on a potassium hydroxide impregnated filter as sulphite. During the sampling period and storage the sulphite will be partly oxidized to sulphate. The filters are extracted with water, and hydrogen peroxide is added to oxidize the remaining sulphite to sulphate. Before analysis by the Thorin method (see Section 3.6.3), the extracted solution has to be treated with a cation exchange resin to remove the potassium and to neutralize the solution.

4.10.2.3 Instrumentation

Same as listed in Section 4.2.1 In addition 100-150 ml polyethylene beakers or 30 ml centrifuge tubes are needed for the extraction.

4.10.2.4 Chemicals

Same as listed in Section 4.2.1. In addition: Hydrogen peroxide (H₂O₂), 30%. Traces of sulphate can be removed from the ion exchange resin by washing with 0.1 M sodium hydroxide, 0.1 M hydrochloric acid and distilled water before use.

4.10.2.5 Reagents

Same as listed in Section 4.2.1.

4.10.2.6 Calibration

Proceed as described in Section 4.2.1.

4.10.2.7 Analytical procedure

1. Leaching of the filters; proceed as described in Section 3.6.1.2.
2. Analysis; proceed as described in Section 4.2.1.

4.10.2.8 Expression of results

The concentration of sulphur dioxide in the air expressed as microgram of sulphur per cubic metre, is given by:

$$C = 1000 \frac{a \cdot v_1}{v_2}$$

a = concentration of sulphur in milligrams per litre in the leaching solution, read from the calibration curve.

v₁ = the volume, in litres, of the leaching solution.

v₂ = the volume, in cubic metres, of the air sample.

4.10.2.9 References

Healy, C. and Atkins, D.H.F. (1975) The determination of atmospheric sulphur dioxide after collection on impregnated filter paper. Harwell, U.K. Atomic Energy Authority (AERE-R 7956).

4.11 Determination of nitrogen dioxide as nitrite

The TGS method is only described in the previous version of this manual (EMEP/CHEM 3/77). The recommended method for NO₂ is sampling with iodide impregnated glass sinter filters followed by the nitrite determination described below.

4.11.1 Determination of nitrite in extracts from impregnated glass sinters

4.11.1.1 Scope and application

This method is applicable to the determination of nitrite in extracts from iodide impregnated glass sinter filters (see Section 3.3.1) in the range 0.02–3 µg NO₂⁻-N/ml. Samples containing higher concentrations must be diluted prior to the analysis and the impregnation matrix have to be added in the dilution step to match the matrix of the calibration standards.

4.11.1.2 Principle

Nitrite (NO₂⁻) and sulphanilamide form a diazo compound in acid solution which by a coupling reaction with NEDA, N-(1-naphthyl)-ethylenediamine-dihydrochloride, gives a red azo dye. The concentration in the solution is determined spectrophotometrically at 540 nm. The calibration standards must match the sample solutions by addition of an iodide matrix.

4.11.1.3 Instrumentation

Spectrophotometer or filter photometer capable of measuring at 540 nm.

Optical glass cells, 10, 20 or 50 mm.

Bulb pipettes, micropipette (adjustable) and dispenser (adjustable).

Capped vials or reagent tubes, 10ml.

Volumetric flasks.

4.11.1.4 Chemicals

All reagents must be of recognized analytical grade. The water used for dilution should be deionized. The water should have a resistance > 10 MΩ/cm. The sample, calibration standards and reagent solution bottles should be made of borosilicate glass, polyethylene or polypropylene.

Phosphoric acid (H₃PO₄), conc.

Sulphanilamide (NH₂C₆H₄SO₂NH₂)

NEDA, N-(1-naphthyl)-ethylenediamine-dihydrochloride
(C₁₀H₇NHCH₂CH₂NH₂*2HCl)

Sodium iodide (NaI)

Sodium carbonate (Na₂CO₃)

Sodium nitrite (NaNO₂)

4.11.1.5 Reagents and solutions

Iodide matrix solution

(10x concentration of leachate): 9.8 g NaI, 1.46 g Na₂CO₃ and 133 µl triethanolamine dissolved and diluted to 100 ml with deionized water.

Mixed reagent

(Sulphanilamide-NEDA solution): To a 1000 ml volumetric flask add about 500 ml deionized water, 8 ml phosphoric acid, 8 g sulphanilamide and 0.2 g NEDA. Dissolve and dilute to 1000 ml with deionized water.

Sodium nitrite stock solution, 1000 µg NO₂-N/ml

Dissolve 4.927 g NaNO₂ which has been dried 1 hour at 105 °C in some deionized water and dilute to 1000 ml with deionized water. This solution can be stored for several months if stored in a borosilicate bottle in a refrigerator.

Nitrite working standard, 10 µg NO₂-N/ml

10 ml of the sodium nitrite stock standard is diluted to 1000 ml with deionized water. This solution can be used for 1 month if stored in a borosilicate bottle in a refrigerator.

Nitrite calibration standards

To 100 ml volumetric flasks add 0, 0.5, 1.0, 5.0, 10.0 and 30.0 ml nitrite working standard, 10 µg NO₂-N/ml and 10 ml iodide matrix solution. Dilute to the mark with deionized water. These calibration standards contain 0, 0.05, 0.10, 0.50, 1.0 and 3.0 µg NO₂-N/ml and have the same iodide concentration as the samples. The range of the calibration solutions may be different if only low concentrations occur, but five calibration standards in addition to a blank should be used. These calibration standards should be made new every day.

4.11.1.6 Analytical procedure

Transfer 0.5 ml sample leachate to a 10 ml vial or test tube and add 3.0 ml mixed reagent. Close the vial or test tube, shake well and read the absorbance at 540 nm after at least 15 min. Treat 0.5 ml of the nitrite calibration solutions the same way and plot the calibration curve. The concentration of the samples in µg NO₂-N/ml are found from the calibration curve. Leachates from field blanks are also treated in the same way, and a representative value for the field blank in µg NO₂-N/ml should be subtracted before the calculation in Section 3.3.1.10.

4.12 Determination of nitric acid and ammonia absorbed on impregnated filters

Nitric acid, ammonia (and hydrochloric acid) collected on an impregnated filter behind an aerosol filter will not generally reflect the true air concentrations due to physical processes and chemical reactions on the filter, mainly with sulphuric acid. By adding the amount of ions in the aerosol filter and on the impregnated filters, the sum of the concentrations of nitric acid and aerosol nitrate, ammonia and aerosol ammonium, and hydrochloric acid and aerosol chlorides can be determined. Separate determination of the two components can be achieved by use of denuders.

The recommended analytical procedures for nitrate and ammonium after the extraction from the impregnated filters (3.6.1.2) are given in Sections 4.1, 4.3 and 4.4. If the extract containing the nitrates is too alkaline for the method applied, it should be treated with a cation resin as described in Section 3.6. If the sample containing the ammonium extracts is too acid for the methods described in Section 4.4, the solutions may be neutralized by adding sodium hydroxide or buffers with sufficient capacity

4.12.1 Determination of nitrate ions by ion chromatography

The analytical method is described in Section 4.1.

4.12.2 Spectrophotometric determination of nitric acid by reduction to nitrite and reaction with sulphanilic acid

The analytical method is described in Section 4.3.1.

4.12.3 Automatic spectrophotometric determination of nitric acid by reduction to nitrite and reaction with sulphanilic acid

The analytical method is described in Section 4.3.2.

4.12.4 Determination of ammonium ions by ion chromatography

The analytical method is described in Section 4.4.1.

4.12.5 Spectrophotometric determination of ammonia as ammonium by the indophenol blue method

The analytical method is described in Section 4.4.2.

4.12.6 Automatic spectrophotometric determination of ammonia as ammonium by the indophenol blue method

The analytical method is described in Section 4.4.3.

4.13 Determination of sulphate in aerosol filters

4.13.1 Determination of sulphate ions by ion chromatography

The procedures after the extraction from the aerosol filter (Section 3.6.2) for Dionex systems and for Waters systems are described in Section 4.1.

4.13.2 Determination of sulphate spectrophotometric by the barium perchlorate – Thorin method

4.13.2.1 Field of application

This method is applicable for the determination of water-soluble particulate sulphate collected on a filter. The working range is within 1 to 80 µg S per filter.

4.13.2.2 Principle

Particulate sulphate collected on a filter is dissolved in water. The concentration of sulphate in the solution is determined spectrophotometrically as described in Section 4.2.1 or 4.2.2.

4.13.2.3 Instrumentation

Same as listed in Section 4.2.1. In addition: 50 ml Erlenmeyer flasks.

4.13.2.4 Chemicals

Same as listed in Section 4.2.1.

4.13.2.5 Reagents

Same as listed in Section 4.2.1.

4.13.2.6 Calibration

Proceed as described in Section 4.2.1.

4.13.2.7 Analytical procedure

Transfer the exposed filters and blank filters to 50 ml Erlenmeyer flasks. Add 20 ml of water, shake well and leave for 30 minutes. (For small filters and low concentrations of sulphate use only 10 ml of water). Proceed according to Section 4.2.1.7 or 4.2.2.6.

4.13.2.8 Expression of results

The concentration of water soluble particulate sulphate in the air sample expressed in micrograms of sulphur per cubic metre, is given by:

$$C = 1000(a - b) \frac{v_1}{v_2}$$

a = concentration of sulphur, in milligrams per litre, read from the calibration curve.

b = concentration of sulphur in the blank sample

v₁ = the volume of water, in litres, used to extract the filter.

4.14 Determination of nitrate and ammonium in aerosol filters

Nitrate, ammonium (and chlorides) collected in an aerosol filter will not generally reflect the true air concentrations due to physical processes and chemical reactions on the filter, mainly with sulphuric acid. By adding the amount of ions in the aerosol filter to the amounts on alkaline and acid impregnated filters behind the aerosol filter, the sum of the concentrations of nitric acid and aerosol nitrate, ammonia and aerosol ammonium, and hydrochloric acid and aerosol chlorides can be determined. Separate determination of the gaseous and aerosol components can be achieved by use of denuders.

Extraction from aerosol filters is described in Section 3.6.

4.14.1 Determination of nitrate ions by ion chromatography

The analytical method is described in Section 4.1.

4.14.2 Spectrophotometric determination of nitrate by reduction to nitrite and reaction with sulphanilic acid

The analytical method is described in Section 4.3.1.

4.14.3 Automatic spectrophotometric determination of nitrate by reduction to nitrite and reaction with sulphanilic acid

The analytical method is described in Section 4.3.2.

4.14.4 Determination of ammonium ions by ion chromatography

The analytical method is described in Section 4.1.

4.14.5 Spectrophotometric determination of ammonium by the indophenol blue method

The analytical method is described in Section 4.4.1.

4.14.6 Automatic spectrophotometric determination of ammonium by the indophenol blue method

The analytical method is described in Section 4.4.2.

4.15 Determination of light hydrocarbons

The analytical method described below is by gas chromatography and FID.

NILU had several years of experience with a hand-made, quite time consuming, non-automated method. This method was based on a two-step concentration of up to one litre of air, dried with K_2CO_3 and NaOH on support (revocation of CO_2), a gas chromatographic separation on Al_2O_3 PLOT column and FID detection (Schmidbauer and Oehme, 1985, 1986).

Considering the high number of samples which needed to be analysed within a very short time after sampling, automated instrumentation was needed. A prototype of a new instrument was presented by Jack Mowrer (IVL, Gothenburg, Sweden) at the Lindau workshop (EMEP/CCC-Report 3/90). This was an instrument for continuous unattended measurements of C_2 - C_5 hydrocarbons at background levels. The instrument was designed and built together with Chrompack (Middelburg, The Netherlands). In the years after Lindau this instrument was further modified by Chrompack in cooperation with H. Bloemen (RIVM, Bilthoven, The Netherlands). More and more laboratories, especially within the EUROTRAC/TOR community, have since then based their on-line measurements of hydrocarbons on a commercial available type of this instrument. The last aspect – the increasing number of users – was one of the reasons for our decision to do the analyses for EMEP with this instrument. The instrument, as it comes from the factory, has to be modified to some extent to act as proper as some of the various homemade devices. The users have introduced some good improvements.

A brief description of the set-up and procedures are given below. The analysis is complicated and should preferably be learned by training.

4.15.1 Instrumentation

4.15.1.1 VOC air analyser (Chrompack, Middelburg, The Netherlands)

Figure 4.15.1 shows the set-up with the original Nafion dryer (not used by NILU) and the 10 canister stream-selector.

Figure 4.15.2 shows the set-up with the dryer as it is used at NILU.

A drying-tube with backflush and heating option has been added between valve V3 and V4. (10 cm teflon-tube 1/4" with 20 micron steel-sinters on both ends, filled with 3 cm of K_2CO_3 on both ends and 4 cm NaOH on support in the middle.)

The first trap is a 1/4" glass-tube packed with Carbosieve, Carbotrap and Carbotrap C - the refocussing trap a 10 cm piece of coat fused silica (Poraplot U).

Figures 4.15.3 and 4.15.4 show the flow-schemes of the seven different steps in an analytical cycle of the thermodesorption unit.

4.15.1.2 Gas chromatography (GC 9000 Chrompack)

Al₂O₃/KCl PLOT column, 50 m, 0.32 i.d. (Chrompack).

VG Minichrom PC based chromatographic data handling system.

4.15.1.3 Gases and materials

All gases are grade 4 or better. They are further cleaned by passage through two different 200 ml cylinders filled with activated charcoal and molecular sieve. This is sufficient for the FID gases, but not for the helium as carrier gas. Helium is further cleaned in a 1/4" steel trap filled with molecular sieve at liquid nitrogen temperature. All tubes which are in contact with the sample are premium grade stainless steel or teflon (drying tube).

4.15.2 Analytical Procedure

The analytical procedure for this type of equipment is given in Figures 4.15.3 and 4.15.4.

Table 4.15.1: Settings of temperatures, gases, flow-directions and gas-flows in the different steps of an analytical cycle of the thermodesorption unit.

Step	Trap 1	Gas	Direction	Flow	Trap 2	Gas	Time
I	270°C	He	Back	20 ml	120°C	He	26 min
II	Ambient	He	Back	20 ml	Ambient	He	60 min
III	-30	He	Back	20 ml	Ambient	He	6 min
IV	-30	Sample	Front	25 ml	Ambient	He	14 min
V	-30	Sample	Front	25 ml	-180	He	6 min
VI	-30	He	Front	5 ml	-180	He	1 min
VII	250	He + HC	Back	8 ml	-180	He + HC	8 min

The consume of liquid nitrogen is about 2 litres per sample.

A chromatogram is given in Figure 4.15.5.

4.15.3 Quality assurance

4.15.3.1 Calibration

NILU is using calibration-gas-mixtures from NIST (USA) to determine the carbon-number-response for the FID.

The standard-gas-mixture is analysed with the same conditions as a sample (same pressure, flowrate, volume and time period) connected to one of the ten ports of the stream-selector. The absolute precision of the read-out of the massflow-controller is therefore not a critical point in calculating concentrations.

NILU is using the n-butane response calculated from a 10 ppb NIST standard as a basis for calculation of carbon-number-response.

The standard gas is connected to port 1 of the multistream-selector and therefore always the first and thereafter every tenth injected sample.

All hydrocarbon peaks in the chromatograms are identified and integrated by hand.

For identification purposes ppm standard-gas-mixtures from Scotty or self-made standards are injected via a home-made injection system.

4.15.3.2 Maintenance

The blank values of the carrier gas are checked by direct connection to one of the ports of the multiposition-valve. A good performance of carrier-gas cleaning is of fundamental importance for a reliable analysis of the very volatile hydrocarbons.

The blank values of the instrument especially of the traps have to be controlled quite often. High boiling compounds on the traps may decompose and give higher background noise of several compounds.

A need for change of the drying-agents is indicated by bad chromatographic performance. On a routine basis the tube is renewed every week.

A record of the raw-area of the standard-runs is very useful to judge the instruments behaviour over longer time.

All gas-flows need to be checked quite often.

4.15.4 References

Schmidbauer, N. and Oehme, M. (1985) Analysis of light hydrocarbons (C₂-C₆) at ppt levels by high resolution gas chromatography. *J. High Res. Chrom. & Chrom. Commun.*, 8, 404-406.

Schmidbauer, N. and Oehme, M. (1986) Improvement of a cryogenic preconcentration unit for C₂-C₆ hydrocarbons in ambient air at ppt levels. *J. High Res. Chrom. & Chrom. Commun.*, 9, 502-505.

EMEP (1990) EMEP Workshop on measurement of hydrocarbons/VOC. Lindau, Federal Rep. of Germany, November, 6-9, 1989. Lillestrøm, Norwegian Institute for Air Research (EMEP/CCC-Report 3/90).

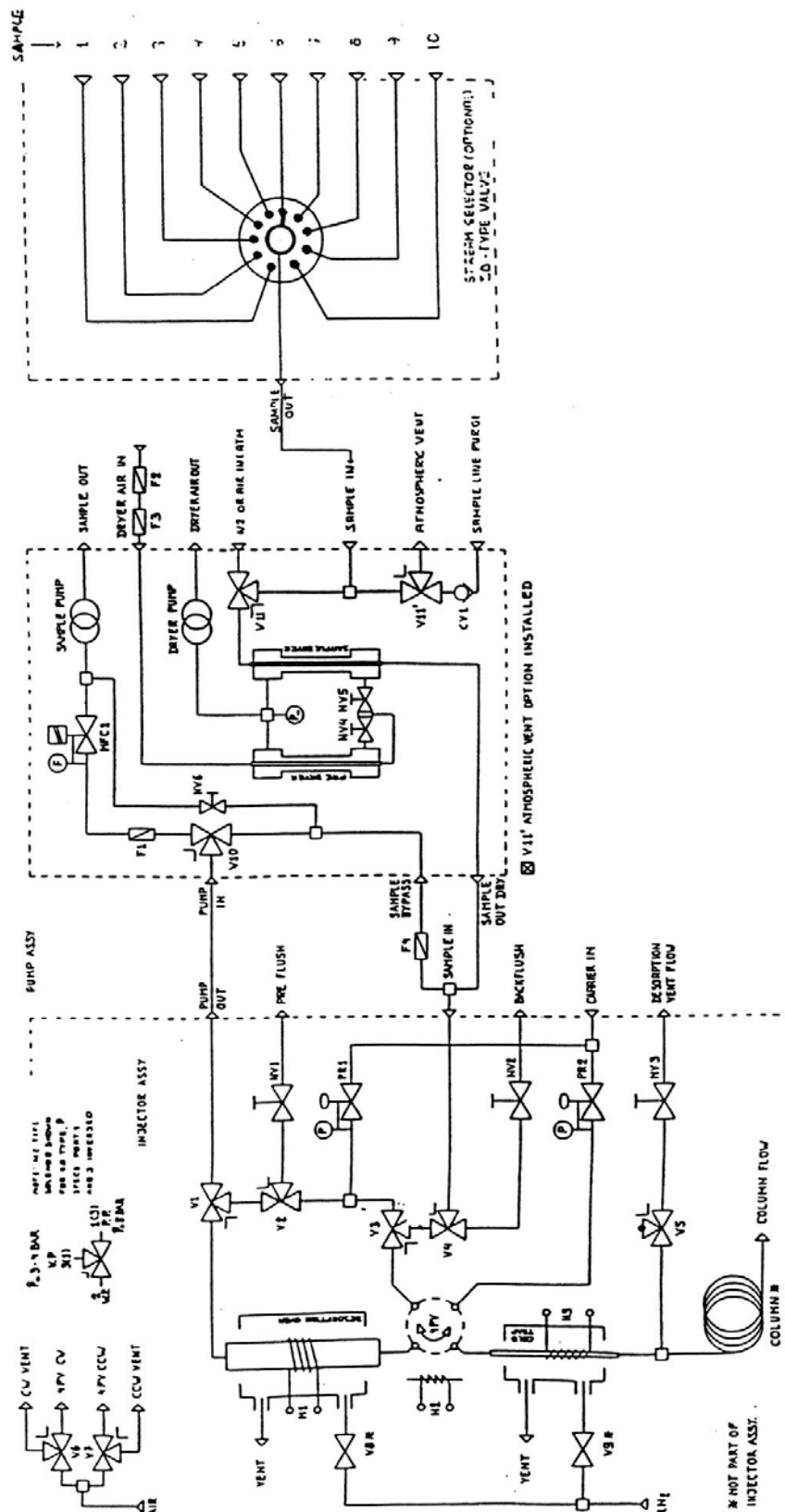

Figure 4.15.1: Original set-up with Nafion dryer (not used by NILU) and the 10 canister stream.

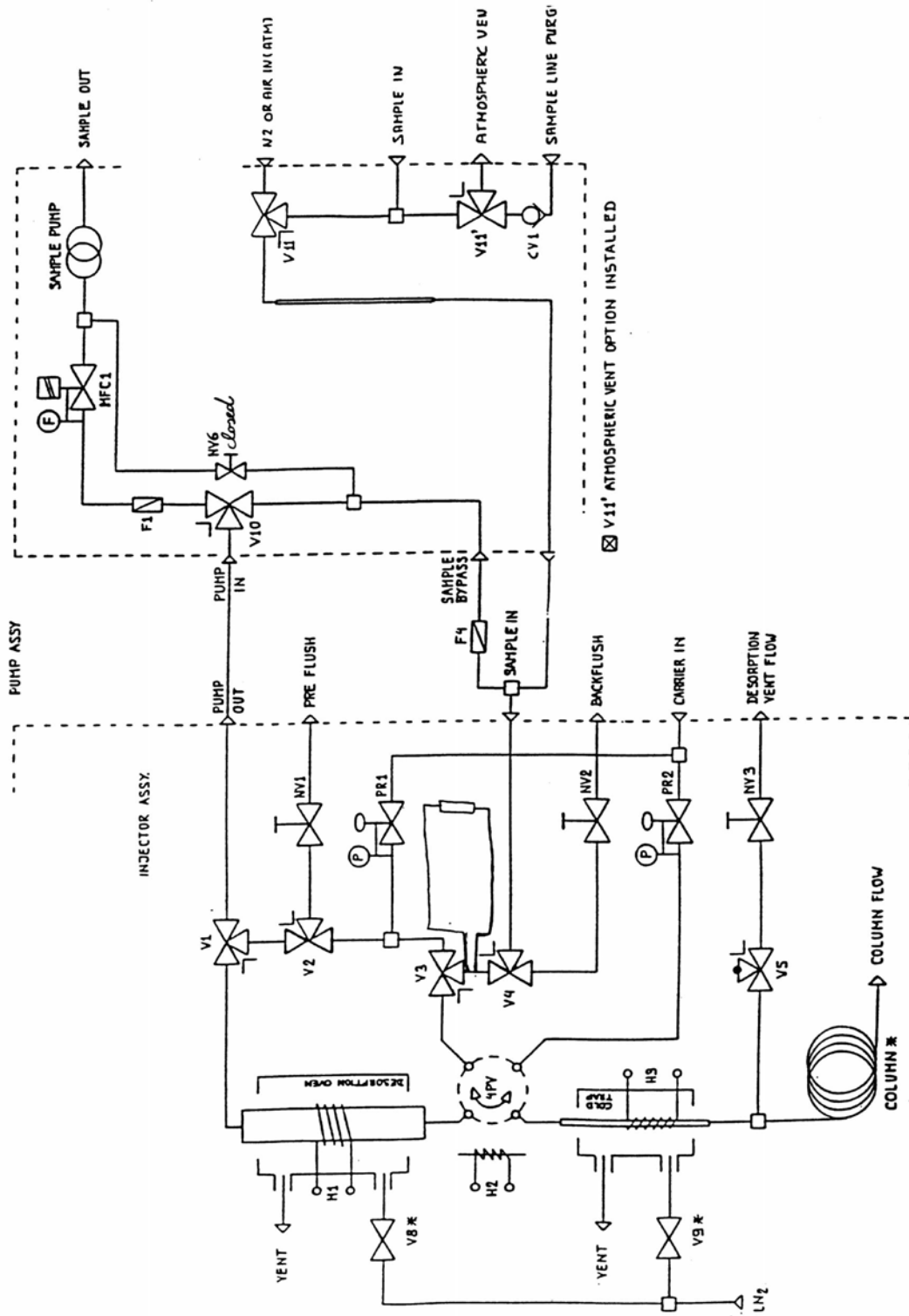
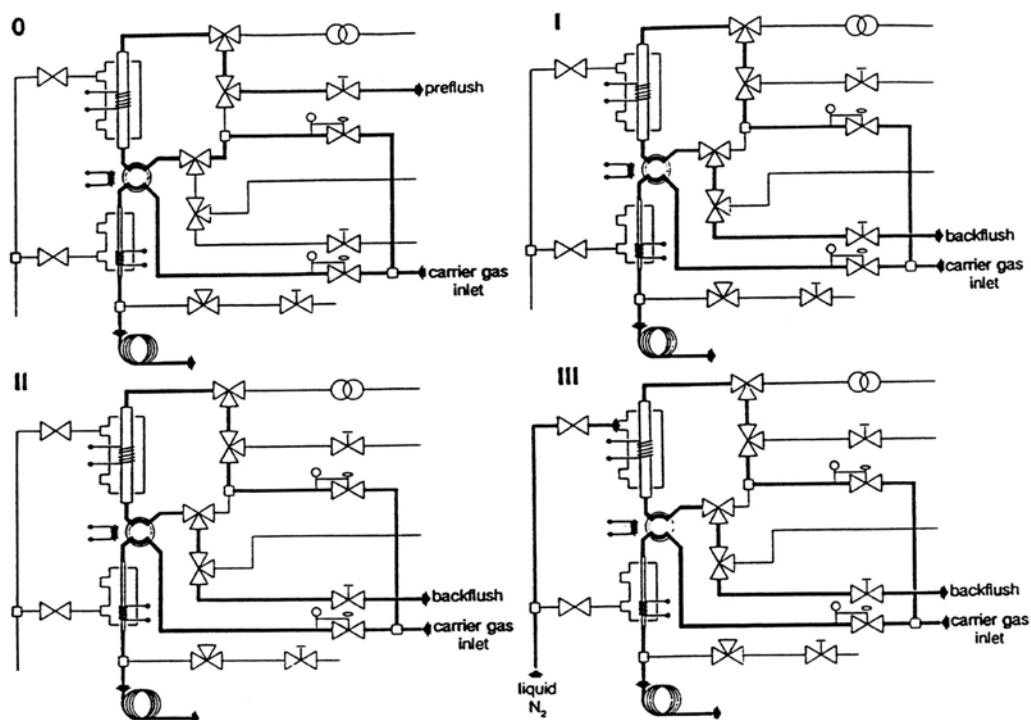

Figure 4.15.2: Instrument set-up with dryer as used at NILU.



0 Run

The system is put into the Run mode by pressing the <Standby> key, turning off the LED. See B: Run mode, above.

NOTE From software revision SWL 1.03L onwards, the system cannot be started from any other stage.

I Backflushinjection

The cold trap is flash heated and the sample, which was cryo-focussed in stage 7, is injected into the capillary column. At the same time the adsorption tube is heated and cleaned by a backflush gas flow to prepare it for the next sample collection.

II Backflush/Stop-wait

This stage allows the user to synchronize the auto-TCT with the GC temperature program or his daily sample frequency (see Auxiliary run functions: Stop).

III Backflush/Oven precool

The sample tube is cooled down to between -170°C and approximately 28°C to prepare it for the next sample collection.

Figure 4.15.3: Analytical procedure - step 0-III.

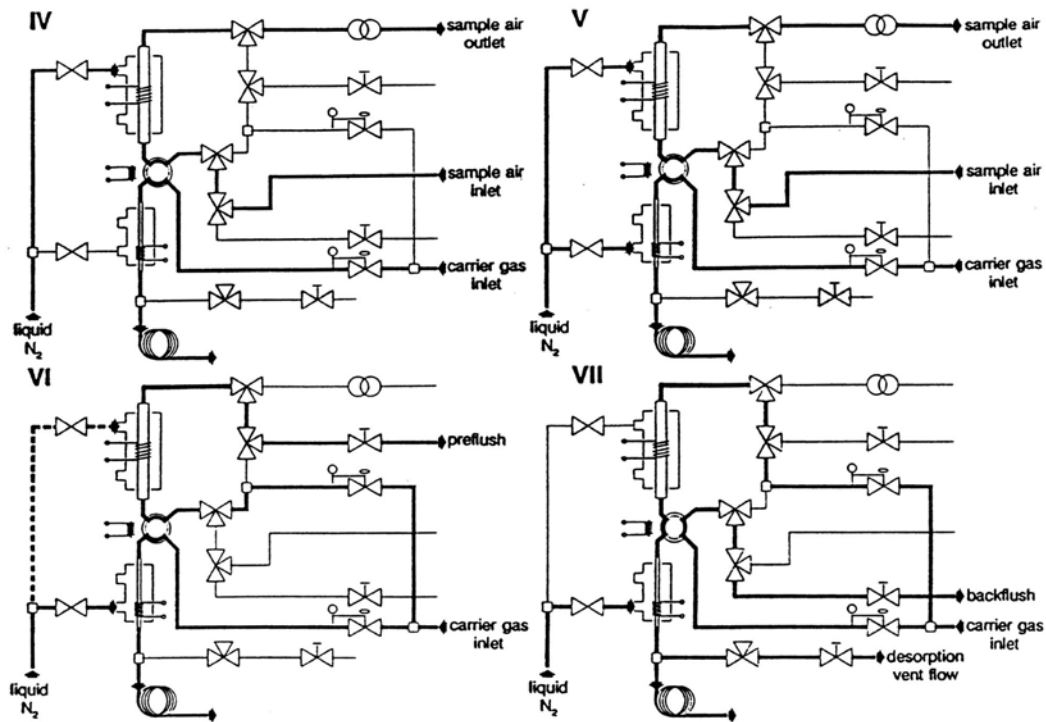

IV Sample collection

The air sample is sucked through the adsorption tube by means of a vacuum or pushed through by means of pressure.

V Sample collection/Trap precool

While sample collection is still in progress, the cold trap is cooling down to between -100°C and -150°C to prepare it for cryo-focussing of the collected components onto the fused silica trap.

VII Preflush

If necessary, water is removed from the adsorption tube by a dry carrier gas flow before the actual desorption starts and the components are transferred to the cold trap.

VII Desorption/trapping

The adsorption tube is heated and the components are transferred to the cold trap by the carrier gas flow and ayofocussed.

Figure 4.15.4: Analytical procedure - step IV-VII.

Injection C: <N20> 3 CS040393,1,1

Acquired on 09-Mar-93 at 20:15:33

Reported on 09-Mar-93 at 23:14:18

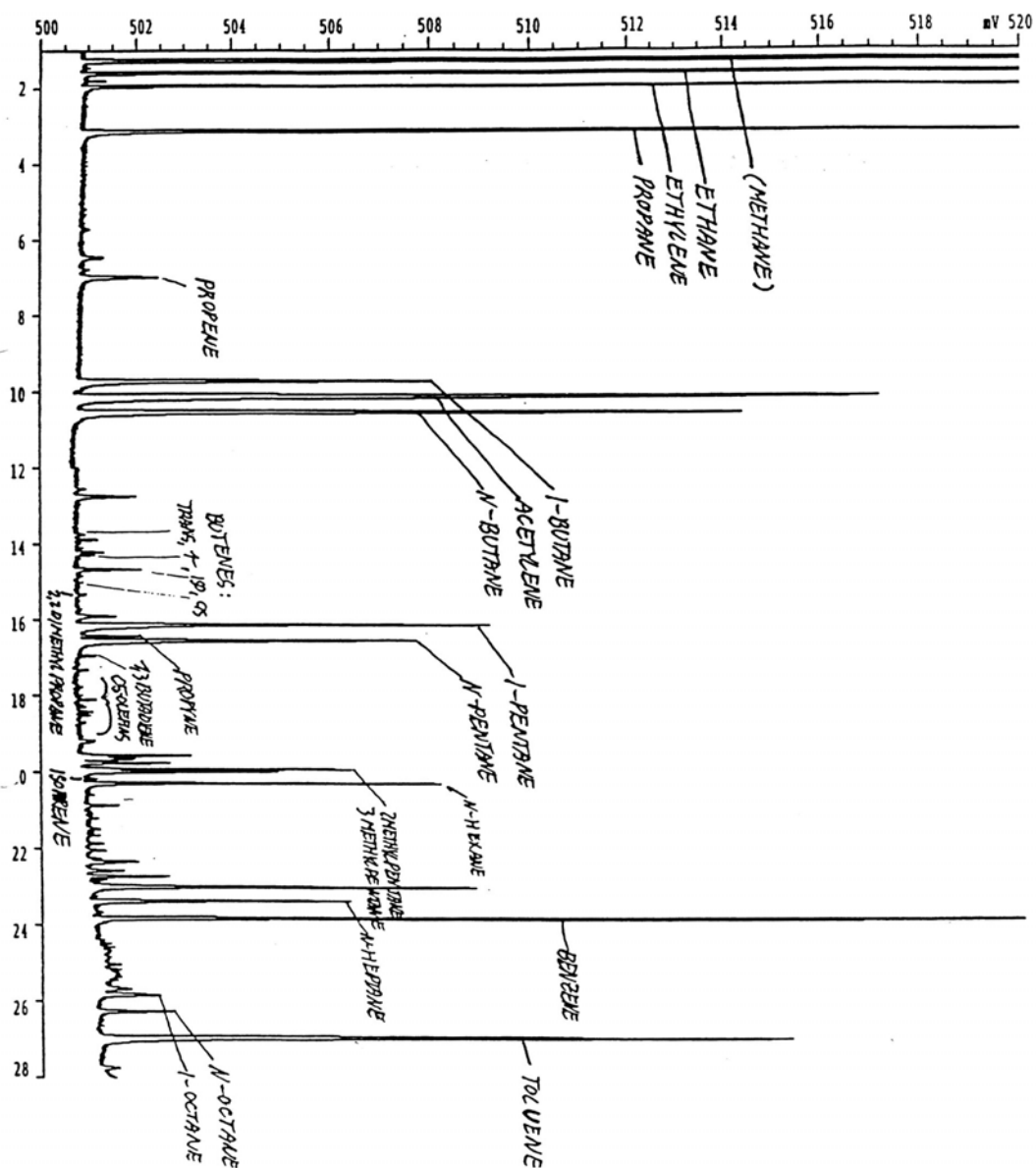

Figure 4.15.5: Chromatogram of light hydrocarbons by GC.

4.16 Determination of aldehydes and ketones in ambient air

Aldehydes and ketones sampled as 2,4-dinitrophenylhydrazones in impregnated tubes can be analysed in extracts with high performance liquid chromatography (HPLC).

4.16.1 Instrumentation

The following instruments and equipment may be used:

- A Hewlett-Packard 1050 modular system, consisting of a 79852A quaternary solvent supply system, a G1306A diode array detector, and a 79855A autosampler.
- Nova-Pak C₁₈, 4 µm particles (No. 86344, Waters Associates), 150 mm * 3.9 mm i.d.).
- Waters In-line Precolumn Filter, No 84560.
- Syringes and volumetric glassware.

4.16.1.1 Chemicals

- Acetonitrile, HPLC-quality, Rathburn Chemicals Ltd., No. RH 1016.
- Methanol, Merc No. 6009.
- Tetrahydrofuran, Merck No 8101.
- Water, quartzdistilled and ion exchanged from a Millipore "MilliQ" water purification system.
- Potassium iodide, p.a, Fluka No. 60400.
- Sulfuric acid, Merc No 714.
- Ethanol.
- Carbonylcompounds needed.
- 2,4-Dinitrophenylhydrazine, Fluka No 42210.

4.16.2 Analytical procedure

Fill a 5 ml syringe with acetonitrile. (Collect the sample extract in a 3 ml narrow neck flask). Eluate the derivatives by slowly (approximate 1.5 ml/min) pushing acetonitrile through the cartridge. Stop the elution when the 3 ml mark is reached. Transfer approximately 0.5 ml of the sample solution to a 2 ml autosampler vial and seal the vial. The sample is now ready for HPLC analysis.

10 µl of a sample or standard solution is separated by using a quaternary mixture of methanol/water/acetonitrile/tetrahydrofuran. Table 4.16.1 shows the gradient profile which is used.

The detection and quantification is carried out at 369 nm (band width 22 nm) using 474 nm (band width 50 nm) as the reference wavelength. The detection and quantification of dicarbonyls is carried out at 440 nm (band width 22 nm) using 337 nm (band width 50 nm).

Following carbonylcompounds should be measured: methanal, ethanal, propenal, propanal, propanone, 2-methyl-propenal, butanal, 2-butanone, 3-buten-2-one, pentanal, hexanal, benzenecarbaldehyde, ethandial, oxopropanal.

Table 4.16.1: Quaternary gradient which separates the carbonylhydrazones of interest (EMEP) at a flowrate of 0.8 ml/min.

Time	% Tetrahydrofuran	% Acetonitrile	% Water	% Methanol
0.0	18.0	22.0	60.0	0.0
0.5	18.0	22.0	60.0	0.0
20.0	8.4	37.4	54.2	0.0
24.0	0.0	0.0	34.0	66.0
40.0	0.0	0.0	15.0	85.0
41.0	0.0	0.0	15.0	85.0
45.0	0.0	100.0	0.0	0.0
48.0	18.0	22.0	60.0	0.0

4.16.3 Blanks

Each day analyses of carbonylcompounds are performed, a laboratory blank should be prepared. Periodically field blanks should be obtained once every week. The blank levels of methanal, ethanal, and propanone will probably change with cartridge batchnumber and the batchnumber of acetonitrile. The blank level should not exceed 0.05 µg/m³ of the carbonylcompound in a sample volume of 750 litres.

4.16.4 Preparation of hydrazones

1. Dissolve 400 mg 2,4-dinitrophenylhydrazine in 2 ml 96% sulphuric acid. This solution is then added, *with stirring*, to 13 ml 75% ethanol. Any undissolved solid is removed by aid of a pasteurpipette.
2. A volume corresponding to 500 mg of the carbonylcompound is transferred to 20 ml ethanol.
3. The carbonylsolution (step 2) is than transferred to the DNPH solution (step 1) with stirring. Let the solution stand for 15 minutes to complete the reaction.
4. Filter the solution in step 3, and recrystallize the hydrazone from aqueous ethanol. (Hydrazones from unsaturated/aromatic carbonyls should be recrystallized from aqueous acetonitrile.)
5. Dry the hydrazone and do a purity test (HPLC-UV).

4.16.5 Calibration

Prepare a stock solution from each carbonylhydrazone by dissolving approximately 5 mg (+/- 1%) in 100 ml acetonitrile. (These stock solutions will be ready for use.) Calibration solutions are prepared by dilution of the stock solutions (1 µg/ml to 2 µg/ml is suitable for most analyses).

4.16.6 Quantification

The concentration of carbonyl compounds in the air sample expressed as $\mu\text{g}/\text{m}^3$, is given by:

$$C = \frac{H(p)cvk}{H(s)V}$$

- C : Concentration of the carbonyl compound in the air sample [$\mu\text{g}/\text{m}^3$]
 c : Concentration of the carbonyl compound in the standard [$\mu\text{g}/\text{ml}$]
 H(s) : Peak height/area of the carbonyl compound in the standard [counts]
 H(p) : Peak height/area of the carbonyl compound in the sample [counts]
 k : Conversion factor (e.g. from hydrazone to carbonyl)
 methanal:0.1429, ethanal:0.1964, propenal 0.2373 etc.
 V : Sample volume [m^3]
 v : Volume of the prepared sample [ml]

4.16.7 Interferences

Failure to remove ozone by the ozone scrubber will result in serious underestimating of some carbonylhydrazones.

4.16.8 References

- Vairavamurthy, A., Roberts, J.M. and Newman, L. (1992) Methods for determination of low molecular weight carbonyl compounds in the atmosphere: a review. *Atmos. Environ.*, 26A, 1965-1993.
- Slemr, J. (1991) Determination of volatile carbonyl compounds in clean air. *Fresenius J. Anal. Chem.*, 340, 672-677.
- Dye, C. and Oehme, M. (1992). Comments concerning the HPLC separation of acrolein from other C_3 carbonyl compounds as 2,4-dinitrophenylhydrazones: a proposal for improvement. *J. High Res. Chrom.*, 15, 5-8.

4.17 Analytical methods for determination of heavy metals

4.17.1 Introduction

At the EMEP WMO-GAW workshop (EMEP, 1997a), inductively coupled plasma mass spectrometry (ICP-MS) was chosen to be the reference technique within EMEP. The exception is mercury where cold vapour atomic fluorescence spectroscopy (CV-AFS) was chosen, but this technique is described in the separate mercury manual. Other techniques may be used, if they are shown to give results of equal quality as obtained with the recommended method. The choice of technique is dependent on the detection limits desired. In

Table 4.17.1 the techniques described in this manual are presented with minimum detection limits. 23 countries, within the EMEP network, monitor and report heavy metal data. As shown in Table 4.17.2 various techniques are used (Berg et al, 2000). In this manual methods including the following four techniques are described: ICP-MS, graphite furnace atomic absorption spectroscopy (GF-AAS), flame-atomic absorption spectroscopy (F-AAS) and CV-AFS. The methods described are generally derived from development and experience gained within the EMEP network as well as information provided by EPA through the Ambient Monitoring Technological Information Centre (AMTEC).

Table 4.17.1: Minimum detection limits. These detection limits are the ultimate values since the blank value from the reagents and filter not have been taken into account.

Element	ICP-MS ng ml ⁻¹ ^{a)}	GF-AAS ng ml ⁻¹ ^{b)}	F-AAS ng ml ⁻¹ ^{c)}
As	<0.01	0.056	0.02
Cd	<0.01	0.0014	0.5
Cr	<0.01	0.0038	2
Cu	<0.01	0.015	1
Ni	<0.03	0.072	2
Pb	<0.001	0.007	10
Zn	<0.02	0.006	0.8
Hg		0.2	0.001

^{a)} Fisons Scientific equipment, VG Instrument Group, Bulletin No.5M/AMSG/390, England

^{b)} Perkin Elmer, "new Analyst™ 800 detection limits", technical note, Norwalk, USA, 1998

^{c)} Parsons, M.L. and Forster, A.L., *Applied Spectroscopy*, **37** (1983) 411-418

Table 4.17.2: Analytical techniques for metal determination within the EMEP network (Berg et al. 2000).

Techniques	Number of laboratories	Described in this manual
NAA	0	
ICP-MS	6	X
GF-AAS	4	X
ICP-AES	1	
PIXE	1	
XRF	1	
F-AAS	5	X
CV-AFS	7	X

4.17.2 Washing procedures

All reusable labware (glass, teflon, polyethylene etc) should be carefully rinsed before use to avoid contamination of the samples. Sampling cans and bottles should be rinsed with de-ionized water and soaked in 3% HNO₃ for 24 hours. After the acid bath the bottles for storing of precipitation samples should be rinsed 3 times and then filled with 1% HNO₃ and stopped.

The sampling cans should be rinsed 3 times with de-ionized water, dried, stopped and packed in two clean plastic bags with zip-locks.

Disposable pipette tips should be placed in a plastic bottle filled with 1% HNO₃. Turn the bottle upside down a few times to assure that the tips are filled with the acid solution. Leave the tips in the acid solution for minimum 12 hours. Pour out the acid solution and rinse the tips by filling the bottle with de-ionized water 3 times. Shake as much as possible of the water out of the bottle and tips, and keep them in the stopped bottle until use.

The rings and filter supports from the filterpacks should be soaked in 1% HNO₃ for 12 hours, rinsed 3 times with de-ionized water.

Autosampler tubes and cups (polystyrene or polyethylene) should be rinsed with de-ionized water, soaked in 1% HNO₃ for minimum 12 hours and rinsed 3 times with de-ionized water before use.

4.17.3 Determination of Cd, Pb, Cu, Zn, Cr, Ni and As by the use of inductively coupled plasma mass spectrometry (ICP-MS)

4.17.3.1 Introduction

ICP-MS is a multi-element technique that is suitable for trace analysis. The technique offers a long linear range and low background for most elements. The detection limits obtained are better or comparable to what is obtained by graphite furnace atomic absorption spectroscopy (GF-AAS). The technique is prone to some interferences that will be described below. Different sample introduction devices may be used in combination with ICP-MS to allow introduction of non-

liquid samples such as solid samples, slurries and gaseous samples. In this chapter, only conventional solution introduction will be described.

4.17.3.2 Principles

ICP-MS is a technique where ions produced in an inductively coupled plasma, are separated in a mass analyser and detected. The sample solution is fed into a nebulizer by a peristaltic pump. The nebulizer converts the liquid sample into a fine aerosol that is transported into the plasma by an Ar gas flow, most often called carrier gas or nebulizer gas. With an ordinary pneumatic nebulizer, only 1-2% of the sample reaches the plasma. In the plasma the sample is evaporated, dissociated, atomised and ionised to varying extent. The produced positive ions and molecular ions are extracted into the mass analyser. A simple quadrupole gives a resolution of 1 amu or more at a peak width of 10% of the peak height. The ions are separated by mass to charge ratio (m/z) and measured by a channel electron multiplier. Detailed description of the ICP-MS technique can be found in various textbooks (Jarvis et al. 1992; Montaser, 1998).

4.17.3.3 Interferences

In analysis by ICP-MS, the following interferences should always be considered:

Isobar overlap

Isobar overlaps exist when two elements have isotopes of essentially the same mass. To overcome this problem 1) a different isotope of the analyte can be chosen or 2) by determining the signal for another isotope of the interfering element and by using the natural abundance information, subtracting the appropriate signal from the analyte isotope signal.

Isobar overlap by polyatomic ions

Isobar overlap may occur due to formation of poly-atomic species. As the name suggests, polyatomic species consist of two or more atomic species, e.g. ArO^+ . They are formed by rapid ion-molecule reactions between components of solvent or sample matrix with the constituents of the plasma. The dominant species in the plasma and its surrounding are Ar, O, N and H. These elements can combine with each other to give a variety of polyatomic ions. The main elements of the solvent or acids used during sample preparation may also participate in these ion-molecule reactions. A large number of polyatomic species may therefore cause interference by isobar overlap. To which extent formation of polyatomic ions occur, depends on several parameters including sampling geometry, plasma and nebulizer conditions, choice of acids and solvents and the nature of the sample matrix. By careful optimisation of the ICP-MS instrument, it is possible to keep the formation of polyatomic species at the minimum and the elemental sensitivity close to maximum. If interference from polyatomic species cannot be avoided by selecting alternative isotopes of the analyte, appropriate corrections should be made to the data.

Isobar overlap by doubly charged ions

Doubly charged ions are detected at half mass ($m/2$). Most of the ions produced in the plasma are single charged. The elements that might produce doubly charged

ions are typically the alkaline metals, alkaline-earth metals and some transition metals. At conventional operating conditions of the plasma and nebulizer, the level of doubly charged ions is small (< 1%).

Physical interferences

Physical interferences are associated with nebulization and transport processes as well as with ion-transition efficiencies. The efficiency of the nebulization and transport processes depends on the viscosity and surface tension of the aspirated solution. Therefore, physical interference (matrix effect) may occur when samples and calibration standards have different matrix. In addition to matrix-matching of samples and calibration standards, the use of internal standard may reduce these problems.

ICP-MS systems are not tolerant to solutions containing significant amounts of dissolved solids. Clogging of nebulizers and salt build-up at the tip of the cones leads to poor sensitivity and considerable signal drift over a short period of time. A level of total dissolved solid (TDS) in the region of 0.1-2 (w/w) % is recommended [Perkin Elmer, 1993]. High matrix concentration generally leads to poor precision. Memory effects may also be severe and time-consuming washout periods required. The use of flow-injection sample introduction may reduce some of these problems.

Memory effects

If there is a considerable difference in concentration between samples or standards that are analysed in sequence, memory effect may occur. The memory effect is caused by sample deposition on the cones, and in the spray chamber. The effect is also dependent on which type of nebulizer that is used. The washout time between samples must be long enough to bring the system down to blank value.

Interference control

It is recommended to determine the concentrations of the main components in the sample to be able to predict possible interference effects on the analytes of interest. Following ions should be monitored in the analysis programs:

^{25}Mg , ^{24}Na , ^{27}Al , ^{31}P , ^{34}S , ^{35}Cl , ^{44}Ca , ^{55}Mn and ^{57}Fe (see Table 11.2).

Reagents and standards

Nitric acid	(HNO_3) 65%
Sodium arsenite	(NaAsO_2)
Cadmium metal	(Cd)
Potassium chromate	(K_2CrO_4)
Copper sulfate	($\text{CuSO}_4 \cdot 5\text{H}_2\text{O}$)
Nickel sulfate	($\text{NiSO}_4 \cdot 6\text{H}_2\text{O}$)
Lead nitrate	($\text{Pb}(\text{NO}_3)_2$)
Zinc metal	(Zn)

ICP-MS stock solutions may be purchased or prepared from chemicals of ultra pure quality (99.9% or better). The standards should be dissolved in an appropriate acid (HNO_3 , HCl , HF) of suprapure quality. In addition to the chemical compound from which the stock solution is made, the acid that is used

should be specified. This makes it possible to calculate the contents of ions that may cause problems by interference (Cl , SO_4^{2-}). HNO_3 gives a very simple spectrum and is for this reason considered as the ideal matrix. Only de-ionised water must be used (resistance $> 18 \text{ M}\Omega/\text{cm}$). Argon gas of high purity grade (99.99% or better) must be used.

Standard stock solutions (1000 $\mu\text{g ml}^{-1}$)

As 1000 $\mu\text{g ml}^{-1}$:

Transfer 9.733 g NaAsO_2 to a 1000 ml volumetric flask. Add distilled de-ionised water to dissolve the salt. Add 5 ml 1:1 HNO_3 and dilute to the mark with distilled de-ionised water. Store the solution in a polyethylene bottle.

Cd 1000 $\mu\text{g ml}^{-1}$:

Transfer 1.000 g cadmium metal to a beaker. Dissolve the metal in 10 ml 1:1 HNO_3 . Transfer the solution to a 1000 ml volumetric flask. Dilute to the mark with distilled de-ionised water. Store the solution in a polyethylene bottle.

Cr 1000 $\mu\text{g ml}^{-1}$:

Transfer 3.734 g K_2CrO_4 to a 1000 ml volumetric flask. Add distilled de-ionised water to dissolve the salt. Add 5 ml 1:1 HNO_3 and dilute to the mark with distilled de-ionised water. Store the solution in a polyethylene bottle.

Cu 1000 $\mu\text{g ml}^{-1}$:

Transfer 3.930 g $\text{CuSO}_4 \cdot 5\text{H}_2\text{O}$ to a 1000 ml volumetric flask. Add distilled de-ionised water to dissolve the salt. Add 5 ml 1:1 HNO_3 and dilute to the mark with distilled de-ionised water. Store the solution in a polyethylene bottle.

Ni 1000 $\mu\text{g ml}^{-1}$:

Transfer 4.477 g $\text{NiSO}_4 \cdot 6\text{H}_2\text{O}$ to a 1000 ml volumetric flask. Add distilled de-ionised water to dissolve the salt. Add 5 ml 1:1 HNO_3 and dilute to the mark with distilled de-ionised water. Store the solution in a polyethylene bottle.

Pb 1000 $\mu\text{g ml}^{-1}$:

Transfer 1.599 g $\text{Pb}(\text{NO}_3)_2$ to a 1000 ml volumetric flask. Add distilled de-ionised water to dissolve the salt. Add 5 ml 1:1 HNO_3 and dilute to the mark with distilled de-ionised water. Store the solution in a polyethylene bottle.

Zn 1000 $\mu\text{g ml}^{-1}$:

Transfer 1.000 g zinc metal to a beaker. Dissolve the metal in 10 ml 1:1 HNO_3 . Transfer the solution to a 1000 ml volumetric flask and dilute to the mark with distilled de-ionised water. Store the solution in a polyethylene bottle.

Commercially available standard solutions may also be used.

Preparation of secondary stock standard

When making mixed calibration standards there might be convenient to prepare a secondary stock standard containing 1000 ng/ml of all the elements of interest, conserved with 10 % (v/v) HNO_3 . This secondary stock standard may be stored

and used for 1 year. *Care must be taken in the preparation of mixed stock standards so that the elements are compatible and stable.*

Preparation of mixed calibration standards

Mixed calibration standards are made by dilution of the secondary stock standard solution to levels within the linear range for the instrument. The same acid concentration and method of spiking must be used in calibration standards as in the samples.

Internal standards

In most analysis there is an advantage to implement three internal standards; one for the low mass region, one for the mass region in the middle and one for the high mass region. Care must be taken in the choice of elements to be used as internal standards:

- The internal standard should not be present in the sample in measurable amounts.
- The internal standard should not suffer from an isobar overlap or polyatomic ion interference or indeed generate them on isotopes of interest.

The following elements are often used as internal standards:

Sc	m/z 45
Rh	m/z 103
In	m/z 115
Re	m/z 185

Sc may be susceptible to isobar overlap from $^{89}\text{Y}^{2+}$, $^{14}\text{N}_2^{16}\text{OH}^+$, $^{28}\text{Si}^{16}\text{OH}^+$ and $^{44}\text{CaH}^+$. This is a problem only when the concentrations of the mother ions are very high. If there is a risk for isobar overlap, Sc should be omitted when calculating the results.

When spiking the samples with internal standard, the precision of the addition of the spike solution should be better than 1%. Internal standard solution may be added before or after dilution to volume, but *equal method of spiking must be used in calibration standards, blanks and samples!*

Quality control standard

The QC-standard (quality control standard) is the initial calibration verification solution. This standard must be an independent standard made from a certified reference solutions that are traceable to certified reference samples. An independent standard is defined as a standard composed of analytes from a different source than the calibration standard. The QC-standard must be prepared in the same acid matrix as the calibration standards and contain the same concentration of internal standard. The concentrations of the QC-standards are determined of the applications in which the standards are used. A typical concentration is 10 ng ml^{-1} . The maximum acceptable deviation will vary from element to element depending on sensitivity, background signal etc. The measured concentration should be within 3 standard deviations of the mean value based on results from analysis of a series of the QC standard. If the measured concentration is more than 3 standard deviations, a re-calibration must be done.

Blank solutions

Three different blank solutions are required; calibration blank, procedural blank and rinse blank.

- **Calibration blank** is used for establishing the calibration curve. The calibration blank consists of the same concentration(s) of the acid(s) used to prepare the final dilution of the calibration standards. In addition, an appropriate concentration of internal standard is added.
- **Procedural blank** (or reagent blank) is used to monitor for possible contaminations resulting from the sample preparation procedure. The procedural blank must be carried through the same procedure and contain the same volume of reagents as the sample solution. In addition an appropriate concentration of internal standard is added.
- **Rinse blank** is consist of 1-2 % (v/v) HNO₃ and is used to flush the sample introduction system between standards and samples.

Tuning solution

Tuning solution is used for tuning and mass calibration of the instrument. The solution is prepared by diluting the secondary stock solution with 1 (v/v) % HNO₃ to produce a concentration of 10 ng/ml for each element. Usually the tuning solution contains elements to cover the entire mass range like Be, Co, In, La, Pb and U.

Sample preparation

Add 100 µl of 10 ng ml⁻¹ internal standard solution to the appropriate amount of autosampler tubes. Transfer 10 ml of the sample digest to the tubes. The samples are now ready for analysis.

4.17.3.4 Calibration and standardisation**Optimisation and stabilising of the instrument**

Allow at least 30 min for the instrument to equilibrate after ignition of the plasma before analysing any element. The optimisation procedures will vary with varying types of instruments. The instrument manual should be consulted with regards to optimisation procedures and specification values. In general all ICP-MS systems shall be optimised to give maximum sensitivity and minimum level of oxides and doubly charged ions. The instrument parameters to adjust are as follows;

- XYZ-position of the torch box
 - setting of the ion lenses
 - nebulizer gas flow rate.
- 1) Aspirate a standard solution containing a suitable concentration (usually 10 ng/ml) of an element in the middle of the mass region (¹⁰³Rh or ¹¹⁵In). Adjust the instrument parameters mentioned above, as described in the instrument manual, to obtain maximum sensitivity of the aspirated element.

- 2) Aspirating a standard solution containing 10 ng/ml ^{140}Ce can check the oxide level at the condition chosen in 1). The ratio between the signal obtained at m/z 156 and m/z 140 should be low (consult instrument specifications for exact value).
- 3) Aspirating 10 ng/ml ^{138}Ba can check the level of doubly charged ions. The ratio between the signals obtained at m/z 69 and m/z 138 should be low (consult instrument specifications for exact value).
- 4) If equal sensitivity in both the low and the high mass region is required, the lens setting should be adjusted to give equal response for 10 ng/ml ^{24}Mg and ^{207}Pb . This will lead to a minor decrease in the sensitivity obtained in point 1).

If poor sensitivity is obtained, following actions should be taken:

- check the sample flow rate of the peristaltic pump and change tubing if necessary.
- check if the sampler and skimmer cones need cleaning
- check nebulizer, spray-chamber, and torch for possible salt depositions, blockages or eventually leaks.
- look for eventually leaks in the torch-spray chamber-nebulizer assembly.
- increase the detector voltage

Mass calibration

A mass calibration check should be conducted to ensure that the masses measured by the instrument, for the tuning solution, are accurate with respect to the standard spectrum. If a signal shift of more than 0.1 amu is observed, mass calibration should be adjusted as described in the instrument manual.

Sequence of analysis

Three calibration blank standards should be analysed to establish a representative blank level. Then the calibration standards are analysed. After calibration, the quality control standard should be analysed to verify the calibration. Flush the sample introduction system with rinse blank, and analyse the blank solution to check carry-over and blank level. Analyse samples if blank level is acceptable. If blank values are too high, repeat flushing of the sample introduction system and analysing of blank solution until acceptable blank level is reached. The calibration blank value, which is the same as the absolute value of the instrument response, must be lower than the method detection limit.

Samples having concentration higher than the established linear concentration range should be diluted into range and reanalysed.

Table 4.17.3: Example of a typical sequence of analysis.

Sequence no.	Sample type	
1-3	Calibration blank	Establish blank level
4-9	Calibration standards	Calibration
10	Quality control standard	Calibration verification (accuracy)

11	Calibration blank	Check for "carry-over"
12-41	Samples	
42	Quality control standard	
43	Calibration standard	
44	Calibration standard	

Table 4.17.4: Isotopes of the priority heavy metals and some possible interferences.

Element	Isotope mass	Relative abundance	Isobar overlap (% abundance)	Poly-atomic species
Cr	52	83.76		ArC ⁺ , ³⁵ ClOH ⁺ ,
	53	9.55		³⁷ ClOH ⁺
Ni	58	67.88	⁵⁸ Fe	⁴² CaO, ⁴⁴ CaO, ⁴⁶ CaO ⁴⁸ CaO
	60	26.23		
	61	1.19		
	62	3.66		
	64	1.08		
Cu	63	69.09		TiO ⁺ , ArNa ⁺ , PO ₂ ⁺
	65	30.91		ArMg ⁺
Zn	64	48.89	⁶⁴ Ni (1.8)	SO ₂ ⁺ , SS ⁺ , ArMg ⁺ ArMg ⁺
	66	27.81		
As	75	100		Ar ³⁵ Cl ⁺
Cd	111	12.75		⁹³ MoO ⁺
	114	28.86	¹¹⁴ Sn (0.66)	
Pb	204	1.48	²⁰⁴ Hg (6.85)	
	206	23.6		
	207	22.6		
	208	52.3		

4.17.4 Determination of Cd, Pb, Cu, Zn, Cr, Ni and As by the use of graphite furnace atomic absorption spectroscopy (GF-AAS)

4.17.4.1 Introduction

Graphite furnace atomic absorption spectroscopy (GF-AAS) is a powerful technique suitable for trace analysis. The technique has high sensitivity (analyte amounts 10⁻⁸-10⁻¹¹ g absolute), the ability to handle micro samples (5-100 µl), and a low noise level from the furnace. Matrix effects from components in the sample other than the analyte are more severe in this technique compared to flame-AAS. The precision is typically (5-10) % using GF-AAS.

4.17.4.2 Principles

A graphite tube is located in the sample compartment of an AA spectrometer with the light from an external light source passing through it. A small volume of sample is placed inside the tube, which then is heated by applying a voltage across its ends. The analyte is dissociated from its chemical bonds and the fraction of

analyte atoms in the ground state will absorb portions of light. The attenuation of the light beam is measured. As the analyte atoms are created and diffuse out of the tube, the absorption rises and falls in a peak-shaped signal. Beer-Lamberts law describes the relation between the measured attenuation and concentration of analyte. A detailed description of the GF-AAS technique can be found in various textbooks (Montaser, 1998).

4.17.4.3 Interference

Background absorption

Background absorption is non-specific attenuation of radiation at the analyte wavelength caused by matrix components. To compensate for background absorption, correction techniques such as continuous light source (D₂-lamp), Zeeman or Smith-Hieftje should be used. Enhanced matrix removal due to matrix modification may reduce background absorption.

Non-spectral interference (Matrix effect)

Non-spectral interference arises when components of the sample matrix alter the vaporization behaviour of the particles that contains the analyte. To compensate for this kind of interference, method of standard addition can be used. Enhanced matrix removal by matrix modification or the use of a L'vov platform may also lead to a reduction of non-spectral interferences.

4.17.4.4 Instrumentation

Atomic absorption spectrophotometer single- or double-beam instrument having a grating monochromator, photomultiplier detector, adjustable slits, equipment for flameless atomization (graphite furnace) and a suitable recorder or PC. The wavelength range must be 190-800 nm.

Hollow cathode lamps for As, Cu, Cr, Ni, Pb and Zn. Single-element lamps are preferred, but multi-element lamps may be used if no spectral interference can occur. Electrodeless discharge lamps may be used if available.

Pyrolytically coated graphite tubes.

4.17.4.5 Reagents and standards

All chemicals must be of analytical grade or better.

Distilled de ionized water

Nitric acid	(HNO ₃) 65%
Sodium arsenite	NaAsO ₂)
Cadmium metal	(Cd)
Potassium chromate	(K ₂ CrO ₄)
Copper sulphate	(CuSO ₄ * 5H ₂ O)
Nickel sulphate	(NiSO ₄ *6H ₂ O)
Lead nitrate	(Pb (NO ₃) ₂)
Zinc metal	(Zn)
Palladium nitrate	(Pd(NO ₃) ₂)
Magnesium nitrate	(Mg(NO ₃) ₂)
Lanthanum nitrate	(La(NO ₃) ₂ *6 H ₂ O)
Ammonium phosphate	((NH ₄) ₃ PO ₄)

Argon (Ar) as purge gas.

Standard stock solutions (1000 µg ml⁻¹)

As 1000 µg ml⁻¹:

Transfer 9.733 g NaAsO₂ to a 1000 ml volumetric flask. Add distilled de-ionised water to dissolve the salt. Add 5 ml 1:1 HNO₃ and dilute to the mark with distilled de-ionised water. Store the solution in a polyethylene bottle.

Cd 1000 µg ml⁻¹:

Transfer 1.000 g cadmium metal to a beaker. Dissolve the metal in 10 ml 1:1 HNO₃. Transfer the solution to a 1000 ml volumetric flask. Dilute to the mark with distilled de-ionised water. Store the solution in a polyethylene bottle.

Cr 1000 µg ml⁻¹:

Transfer 3.734 g K₂CrO₄ to a 1000 ml volumetric flask. Add distilled de-ionised water to dissolve the salt. Add 5 ml 1:1 HNO₃ and dilute to the mark with distilled de-ionised water. Store the solution in a polyethylene bottle.

Cu 1000 µg ml⁻¹:

Transfer 3.930 g CuSO₄* 5H₂O to a 1000 ml volumetric flask. Add distilled de-ionised water to dissolve the salt. Add 5 ml 1:1 HNO₃ and dilute to the mark with distilled de-ionised water. Store the solution in a polyethylene bottle.

Ni 1000 µg ml⁻¹:

Transfer 4.477 g NiSO₄*6H₂O to a 1000 ml volumetric flask. Add distilled de-ionised water to dissolve the salt. Add 5 ml 1:1 HNO₃ and dilute to the mark with distilled de-ionised water. Store the solution in a polyethylene bottle.

Pb 1000 µg ml⁻¹:

Transfer 1.599 g $\text{Pb}(\text{NO}_3)_2$ to a 1000 ml volumetric flask. Add distilled de-ionised water to dissolve the salt. Add 5 ml 1:1 HNO_3 and dilute to the mark with distilled de-ionised water. Store the solution in a polyethylene bottle.

Zn 1000 $\mu\text{g ml}^{-1}$:

Transfer 1.000 g zinc metal to a beaker. Dissolve the metal in 10 ml 1:1 HNO_3 . Transfer the solution to a 1000 ml volumetric flask and dilute to the mark with distilled de-ionised water. Store the solution in a polyethylene bottle.

Commercially available standard solutions may also be used.

Calibration standards

Calibration standards are prepared by single or multiple dilutions of the stock metal solutions. Prepare a reagent blank and at least 3 calibration standards in graduated amount in the appropriate range of the linear part of the curve. The calibration standards must contain the same acid concentration as in the samples following processing. For precipitation samples, that would be 1% (v/v) HNO_3 and for suspended particulate matter 10% (v/v) HNO_3 . The calibration standard should be transferred to polyethylene bottles.

Table 4.17.5: Calibration range.

	As	Cd	Cr	Cu	Pb	Ni	Zn
Calibration range ($\mu\text{g l}^{-1}$)	0-100	0-5	0-40	0-50	0-50	0-40	0-5

4.17.4.6 Instrument procedure

The operating instructions will vary between various brands and models of satisfactory instruments, making it virtually impossible to give precise details of a proposed GF-AAS method that is guaranteed to reduce interference effects on all commercial instruments. *The instrument manual should be confirmed in regards of operating instructions.* A careful interference study and calibration procedure as given in the particular instrument manual must be carried out by the analyst. Some general guidelines are given below.

- Allow the light source(s) a stabilisation time of 10-15 minutes before analysing.
- Set the monochromator to the appropriate wavelength.
- Align the furnace for maximum transmission of radiation.
- Carefully balance the intensity of the hollow cathode lamp and the D_2 -lamp if such background correction is used.
- A temperature calibration of the furnace should be done.
- Optimise the injection position of the autosampler capillary in such a way that the sample droplet is gently placed in the bottom of the graphite tube. A convenient sample volume for most analyses is 20 μl .

- Make sure that the silica windows in the furnace compartment are clean to ensure maximum transmission of radiation.
- All new graphite tubes must be thermally conditioned as described by the manufacturer.
- For quantification of absorption signals peak area is recommended.

4.17.4.7 *Setting up a temperature programme*

A temperature programme consists most commonly of four steps: Drying, pyrolysis, atomization and cleaning.

Drying step: A quick ramp (5 s) to 15°C below the boiling point of the solvent. Then a slow ramp (25 s) to reach a temperature just above the solvents boiling point. This provides a gentle evaporation without sputtering. Hold the furnace at the selected temperature until drying is complete (5- 10 s). The drying time will vary with sample volume and salt content. A purge gas flow of 250-300 ml min⁻¹ is normally used.

Pyrolysis step: A pyrolysis curve should be made to find the appropriate temperature to use in this step without losing any analyte. Consult the instrument manual for the procedure of making a pyrolysis curve. In a pyrolysis step a typical ramp will vary between 20-50 °C s⁻¹. Too steep ramp may cause sputtering. A purge gas flow of 250-300 ml min⁻¹ is normally used.

Atomization step: An atomization curve should be made to find the appropriate temperature to use in this step. Consult the instrument manual for the procedure of making an atomization curve. The lowest temperature that still gives maximum signal should be used in order to extend the lifetime of the graphite tube. Zero ramp time is used in this step. Gas stop during atomization is recommended.

Cleaning step: A tube cleaning cycle after the analyte measurement should be done to remove any remains of sample and thereby avoid memory effects. A purge gas flow of 250-300 ml min⁻¹ is normally used.

All times and temperatures are guidelines only.

4.17.4.8 *Instrument performance*

The characteristic mass (sometimes called sensitivity) is defined as the absolute mass of an element that will absorb 1% of the incoming radiation. This equals a signal of 0.0044 absorbance units (AU). The characteristic mass may be used as an indicator of instrument optimisation. Values of the characteristic masses are most often given in the instrument documentation. Experimental values for comparison can be determined by measuring the absorbance signal (area) of a known mass of analyte and calculate using the following formula:

$$m_o = V_s * C_s * 0.0044 \text{ AU} / \text{observed peak area}$$

m_o : Characteristic mass (ng)

V_s : Standard volume injected (ml)

C_s : Standard concentration (ng ml^{-1})

Table 4.17.6: Proposed instrument parameters.

	λ , nm	slit	Drying temp	Pyrolysis temp	Atomization temp	Chemical modifier	Pyrolysis temp.	Atomization temp.
As	193.7	0.7	120	500	2300	$\text{Pd}(\text{NO}_3)_2 + \text{Mg}(\text{NO}_3)_2$	1300	2300
Cd	228.8	0.7	120	350	1800			
Cr	357.9	0.7	120	1350	2660	$\text{Mg}(\text{NO}_3)_2$	1650	2500
Cu	324.7	0.7	120	900	2600			
Pb	217.0	0.7	120	550	2000	$(\text{NH}_4)_3\text{PO}_4$ or $\text{La}(\text{NO}_3)_2$	700	1800
Ni	232.0	0.2	120	1200	2600			
Zn	213.9	0.7	120	350	1800	$\text{Mg}(\text{NO}_3)_2$	700	1800

Other operating parameters should be set as specified by the particular instrument manufacturer.

4.17.4.9 Chemical modifiers

In order to achieve better separation between analyte and matrix prior to atomisation, a chemical modifier can be used. The role of the modifier is most often to stabilise the analyte making higher temperatures in the pyrolysis step possible without any loss of analyte. The concentration level of most modifier mixtures is usually in the ppm level. The injection volume most often is in the 5-20 μl region. The modifier mixture should be injected and dried prior to sample injection. For suggestions of chemical modifiers for the various elements see Table 4.17.6.

4.17.4.10 Sequence of analysis

- Start the analysis with an “empty tube” run. If a significant signal is obtained, a cleaning step (2650°C, 2-3 s) should be run repetitively to remove the remains in the tube. If this is not sufficient, the graphite tube should be replaced.
- The chemical modifier solution (if used) should be checked for contamination in a separate run.
- The blank solution should be analysed to establish a blank level.
- In addition to the blank standard, at least 3 standards should be selected to cover the linear range. Repeat the analysis until good agreement between replicates and a linear calibration curve is obtained.
- A quality control standard should be analysed to verify the calibration.
- Samples that are found to have concentration higher than the highest standard should be diluted into range and reanalysed.
- To monitor the performance of the graphite tube, a mid-level standard and a blank standard should be run after every 10th sample.

4.17.5 Determination of zinc by flame atomic absorption spectroscopy (F-AAS)

4.17.5.1 Introduction

F-AAS is a very specific technique prone to few interference effects. F-AAS is a single element technique with analyte determinations in the mg l^{-1} region as routine for most elements.

4.17.5.2 Principles

A liquid sample is nebulized to form a fine aerosol, which is mixed with fuel and oxidant gasses and carried into a flame. In the flame the sample is dissociated into free ground state atoms. A light beam from an external light source emitting specific wavelengths passes through the flame. The wavelength is chosen to correspond with the absorption energy of the ground state atoms of the desired element. The measured parameter in F-AAS is attenuation of light. Lambert-Beers law expresses the relationship between the attenuation of light and concentration of analyte.

4.17.5.3 Interferences

F-AAS is known as a technique with few problems related to interference effects. The interferences that occur are well defined, as are the means of dealing with them. For analysis of a few elements the type and temperature of the flame are critical; with improper conditions ionisation and chemical interferences may occur.

Ionisation

Ionisation of the analyte atoms in the flame depletes the levels of free ground state atoms available for light absorption. This will reduce the atomic absorption at the resonance wavelength and lead to erroneous results. The degree of ionisation of a metal is strongly influenced by the presence of other ionisable metals in the flame. By addition of an excess of a very easily ionised element to the blanks, standards and samples the effect of ionisation can usually be eliminated. Ionisation is most common in hot flames such as nitrous oxide- acetylene flames. In an acetylene-air flame ionisation is most often limited to be a problem in analysis of the alkali- and alkaline earth metals.

Chemical interference

The most common type of chemical interference occurs when the sample contains components that forms thermally stable compounds with the analyte and thus reduce the rate at which it is atomised. Adding an excess of a compound that form thermally stable compounds with the interfering element eliminates chemical interference. For example, calcium phosphate does not dissociate completely in the flame. Addition of Lanthanum will tie up the phosphate allowing calcium to be atomised. A second approach to avoid chemical interference is, if possible, to use a hotter flame. Using the method of standard addition can also control chemical interference.

Physical interference

If the physical properties as viscosity and surface tension vary considerably between samples and standards, the sample uptake rate or nebulization efficiency may be different and lead to erroneous results. Dilution of samples or method of standard addition or both can be used to control these types of interferences.

Background absorption and light scattering

Matrix components that are not 100% atomised and that has broadband absorption spectra may absorb at the analytical wavelength. Tiny solid particles in the flame may lead to scattering of the light over a wide wavelength region. The background absorption can be accounted for by using background correction techniques such as continuous light source (D_2 -lamp) or Smith-Hieftje.

4.17.5.4 Instrumentation

Atomic absorption spectrophotometer single- or double-beam instrument having a grating monochromator, photomultiplier detector, adjustable slits, equipped with a air-acetylene burner head and a suitable recorder or PC. The wavelength range must be 190-800 nm.

- Hollow cathode lamp for Zn.
- Electrodeless discharge lamp for Zn may be used if available.
- Pressure reducing regulators for acetylene and air.
- Pipettes (μ l) with disposable tip in various sizes.

4.17.5.5 Reagents and standards

All reagents must be of analytical grade or better.

Distilled de-ionized water

Nitric acid (HNO_3)

Zinc metal (Zn)

Acetylene gas (99,99% or better)

Air supply

Standard stock solutions (1000 μ g ml^{-1})

Zn 1000 μ g ml^{-1} :

Transfer 1.000 g zinc metal to a beaker. Dissolve the metal in 10 ml 1:1 HNO_3 . Transfer the solution to a 1000 ml volumetric flask and dilute to the mark with distilled de-ionised water. Store the solution in a polyethylene bottle.

Commercially available standard solutions may also be used.

Calibration standards

Calibration standards are prepared by single or multiple dilutions of the stock metal solution. Prepare a reagent blank and at least 3 calibration standards in graduated amount in the appropriate range of the linear part of the curve. The calibration standards must contain the same acid concentration as will result in the samples following processing. For precipitation samples, that would be 1% (v/v) HNO_3 and for suspended particulate matter 10% (v/v) HNO_3 . The calibration standard should be transferred to polyethylene bottles.

4.17.5.6 Instrumental procedure

The operating procedure will vary between instrument brands, *so the instrument manual should be followed carefully*. The position of observation and the fuel:oxidant ratio must be optimised. Some general guidelines are outlined below

- Light the hollow cathode lamp or electrode discharge lamp and D₂-lamp if such background correction is used. Set the lamp current to the value specified by the manufacturer.
- Position the monochromator at wavelength 213.9 and choose slit with 0.7 and slit height “high”.
- Carefully balance the intensity of the hollow cathode lamp and the D₂-lamp if such background correction is used.
- Align the burner head to assure that the centre of the light beam passes over the burner slot.
- Light the flame and regulate the flow of fuel and oxidant to produce an oxidising flame (lean blue).
- Aspirate calibration blank and establish a zero point.
- Aspirate standard solutions and construct a calibration curve.
- Aspirate distilled water after each standard or sample.

4.17.5.7 Instrument performance

The “characteristic concentration” (sometimes called sensitivity) is defined as the concentration of an element (mg l⁻¹) that will absorb 1 % of the incoming radiation. This equals a signal of 0.0044 absorbance units (AU). The “characteristic concentration” is instrument dependent and is calculated as follows:

$$C = (S * 0.0044 \text{ AU}) / \text{measured absorbance}$$

C: Characteristic concentration (mg l⁻¹)

S: Concentration of measured standard (mg l⁻¹)

Knowing the “characteristic concentration” allows the analyst to check if the instrument is correctly optimised and performing up to specifications.

4.17.5.8 Sequence of analysis

- Aspirate calibration blank and establish a blank level
- Aspirate calibration blank and standard solutions and construct a calibration curve. Use at least 3 standard solutions in addition to the calibration blank to cover the linear range. Every point at the calibration curve should, if possible, be based on replicate analysis. Distilled water should be aspirated after each standard and sample.
- A quality control standard should be analysed to verify the calibration.
- A calibration blank should be analysed to check for memory effects.
- Aspirate unknown samples.
- Aspirate a quality control standard for every 10th sample to check for drift.

- Samples that are found to have concentration higher than the highest standard should be diluted and reanalysed.

4.17.6 References

Berg, T., Hjellbrekke, A.G. and Larsen, R. (2000) Heavy metals and POPs within the EMEP region 1998. Kjeller, Norwegian Institute for Air Research (EMEP/CCC-Report 2/2000).

EMEP (1997) EMEP-WMO workshop on strategies for monitoring of regional air pollution in relation to the need within EMEP, GAW and other international bodies. Aspenäs, Sweden, 2-4 June 1997. Kjeller, Norwegian Institute for Air Research (EMEP/CCC-Report 10/97).

Jarvis, K.E., Gray, A.L. and Houk, R. S. (1992) Handbook of inductively coupled plasma mass spectrometry. Glasgow, Blackie.

Montaser, A. (1998) Inductively coupled plasma mass spectrometry. New York, Wiley.

4.18 Analysis of mercury in precipitation and air

4.18.1 Analysis of mercury in precipitation

4.18.1.1 Instrumentation

The most common procedure for the analysis of mercury in precipitation is oxidation with BrCl, pre-reduction with NH₂OH·HCl followed by reduction of the aqueous Hg to Hg⁰, purging onto gold traps and thermal desorption and analysis using Cold Vapour Atomic Fluorescence Spectroscopy (CVAFS) (Bloom and Crecelius, 1983; Bloom and Fitzgerald, 1988). The analysis procedure can be performed in manual or automated modes. A detection limit (defined as 3 times the standard deviation of the blank concentration) 2 ng/l is necessary for the accurate analysis of total mercury in precipitation samples from remote stations.

The most reliable technique for the analysis of mercury is atomic fluorescence spectrometry (AFS). Atomic absorption spectrometry (AAS) may be used but requires larger sample volumes due to higher detection limit. AFS and AAS instruments are available from a number of different manufacturers.

Borosilicate glass is the recommended material for the reaction and purging of flasks where mercury is reduced and volatilised for the pre-concentration step. Acid-washed Teflon tubing should be used. Ordinary polyethylene or rubber tubing is not suitable.

4.18.1.2 Sample storage and handling

All water samples for mercury analyses must be handled with care in order to avoid contamination. Sample bottles should only be handled in laboratories where mercury or any mercury compounds in pure or concentrated forms have not been handled. Samples for analysis of total mercury should be preserved with low blank HCl (5 ml 30% acid/l). Precipitation samples should be stored in the collection bottles, in double plastic bags in the dark in a refrigerator or cold room. A storage time up to 6 months can be acceptable but it is absolutely necessary to test this under the conditions employed in the individual laboratories. Shorter storage times are recommended if methylmercury is analysed. Plastic gloves must always be used when the plastic bags are opened. If possible, the plastic bags should be left around the bottles during the analysis. The bottles should not be placed on laboratory surfaces that may have been exposed to mercury or chemical reagents containing mercury.

4.18.1.3 Chemicals and glassware

Purging flasks for SnCl₂-reduction:

Acid-cleaned borosilicate glass (Pyrex) wash-bottles are used.

Hg-free Nitrogen/Hg-free Argon:

The gas should go through a gold trap or coal filter

High purity water:

Purified water with >18 MΩ resistance and a low mercury blank.

Air in laboratory:

All glassware and samples should be handled in a laboratory containing low concentrations of mercury (not more than 10 ng/m³ if possible). A clean bench (or some other clean zone arrangement) of class 100 should be used for handling reagents, for some sample treatment and for the drying of glassware.

Hydrochloric acid:

30% HCl (Suprapur) from Merck is recommended. Other manufacturers may provide equally high quality hydrochloric acid. Regular blank checks should be made. For the preparation of SnCl₂ solution, 37% HCl (P.A.) is necessary.

Brominemonochloride solution:

Must be prepared in a fume hood with great care. Use safety goggles. Add 11,0 g KBrO₃ and 15,0 g KBr to 200 ml high purity water. Stir the solution with a magnetic bar for 1 hour and add 800 ml 30% HCl **very slowly**. Large amounts of acid fumes and gaseous free halogens will form and will evaporate from the solution. The solution can be prepared in an empty HCl bottle.

Hydroxylammonium chloride:

Dissolve 120 g NH₂OH·HCl in 1 l high purity water. This chemical reagent sometimes contains high mercury concentrations. Adding 1 g Chelex 100 ion exchange material can lower the mercury content. Blanks must be checked carefully.

Stannous Chloride solution:

Dissolve 200 g SnCl₂·2H₂O in 100 ml 37% HCl (p.a.) and dilute to 1 l with high purity water. Purge this solution with mercury-free N₂ for 12 hours and then store it in the dark. Aliquots of 100 ml may be removed and used as working solutions for analysis. These aliquots should be purged continuously with mercury-free N₂.

Mercury calibrating solution:

Standard solutions can be prepared from commercially available mercury standards. A parallel check using two standard solutions of different origin is recommended. One of these can be made from pure chemicals (e.g. Hg⁰ dissolved in concentrated HNO₃ and diluted to the appropriate volume).

4.18.1.4 Pre-treatment

The collected samples are preserved with HCl prior to storage or during sampling. Before analysis a chemical oxidation step is performed using BrCl. This reagent efficiently converts stable mercury forms to water soluble species that can be easily reduced by SnCl₂. Before analysing the sample, excess BrCl is removed using a mild reducing agent such as NH₂OH·HCl or ascorbic acid.

4.18.1.5 Preparation of reducing vessels

Fill the wash bottles with about 50 ml water containing 2.5 ml of the SnCl_2 solution and 2 ml 30% HCl. Purge the solution with N_2 for 20 minutes before checking the bubbler blank value.

At the end of each day, the bottles should be rinsed thoroughly with de-ionised water and then filled (at least covering the glass frit) with Aqua Regia until use. Before starting the next set of analyses, the Aqua Regia should be transferred to a storage bottle (Aqua Regia can be re-used for up to a month) and the reduction vessel rinsed, first with de-ionised water and then with high purity water (e.g. Milli-Q).

4.18.1.6 Reduction step

The bubbler blank value should be checked by connecting a gold trap to the bubbler and purging the solution with N_2 for 20 minutes, then analysing the mercury collected. The mercury collected on the gold trap is the bubbler blank and should not exceed a few picograms.

In all collection and purging steps, a glass tube containing baked quartz wool should be connected between the bottle and the gold trap to avoid exposing the gold surface to droplets of acid solution.

After the bubbler blank has been checked, a clean gold trap should be connected to the outlet and an aliquot of the pre-treated precipitation sample added to the bubbler flask. The bubbler flask should then be placed on an electronic balance and the amount of sample added weighed. The reduction and purging should be allowed to proceed for 10 to 20 minutes.

4.18.1.7 Detection

The traps should be dried at about 40°C in a mercury-free N_2 flow for 5 minutes prior to analysis. They should then be connected to the AFS detector on line with the helium gas flow. The mercury is then thermally desorbed either directly into the detector or onto an analytical trap. If an analytical trap is used, a second heating step should be performed before the detection. The advantage of the dual amalgamation is that the influence of any interfering substances adsorbed on the first trap may be reduced and also that the mercury adsorbed onto the second analytical trap will be more easily desorbed and a sharper peak obtained.

After the analytical step the gold trap should be allowed to cool. It should then be removed from the gas stream and stoppered with Teflon plugs. It should be stored in a plastic bag if not immediately used again.

4.18.1.8 Calibration

Standard solutions can be prepared from commercially available mercury standards. Calibration should be performed by using 4 standards in each run.

4.18.1.9 *Quality control - Quality assurance*

The calibration step is critical. In general, the basic principle is always to use two independent calibrant solutions. One of these can be made from pure chemicals (e.g. Hg⁰ dissolved in concentrated HNO₃ and diluted to the appropriate volume). For mercury, commercially available standard solutions can be used but regular checks against a reference standard must be made. Certified reference materials should be used if available, but reference standards can also be prepared from pure mercury compounds. Traceability is an important step and all standard solutions must be regularly checked against a reference material. In the absence of aqueous phase reference standards, solid materials may be used.

As an independent check on the analytical results, a Hg⁰ vapour source can be used consisting of liquid mercury in an enclosed vessel from which vapour samples can be drawn with a gas tight syringe.

4.18.1.10 *Special problems*

The analysis of low level mercury concentrations in aqueous samples is associated with a number of potential errors mainly emanating from blank problems and poor recovery.

Blank values usually arise from the use of reagents of poor quality or from glass vessels or tubing. Careful checking and documentation of all steps in the analytical procedure is necessary in order to identify the source of the blank.

4.18.1.11 *Summary*

	Recommendation	Acceptable alternatives
Sample pre-treatment	BrCl oxidation, NH ₂ OH·HCl pre-reduction	Ascorbic acid
Preconcentration	SnCl ₂ reduction, purging, collection on gold traps	
Detection	AFS	AAS
Detection limit	< 2 ng/l	
QA/QC	Blank determinations, use of traceable reference materials	

4.18.2 *Analysis of mercury in air*

Mercury collected on gold traps is analysed after desorption of the mercury.

4.18.2.1 *Sample pre-treatment*

Before analysing the mercury content of the gold trap, a drying step is recommended. Small amounts of water vapour may have condensed on the gold surface and may interfere in the analysis step. The gold traps can be heated to 40-50°C for 5-10 min in a stream of dry N₂ without any measurable loss of mercury.

4.18.2.2 Analysis

The analysis of mercury in air samples is generally made using double amalgamation CVAFS (Fitzgerald and Gill, 1979; Bloom and Fitzgerald, 1988). In this procedure, the gold trap is mounted in series with a second analytical trap in a gas stream (Hg-free argon) leading to the CVAFS detector. Heating is achieved with a heating wire (e.g. NiCr). In the first step the mercury is thermally desorbed from the first sampling trap onto the second analytical trap. The second trap is then rapidly heated and the mercury is transported into the CVAFS with an integrator.

The analytical steps are as follows:

1. thermal desorption from the field trap to the analytical trap: 500°C for 4 minutes, with 30 ml/min flow rate
2. thermal desorption from the analytical trap to the AFS: 800°C for 25 seconds, with 30 ml/min flow rate
3. Total gaseous mercury calculation: Peak Area of the integrated AFS Signal.

4.18.2.3 Calibration

Mercury-saturated air is supplied from a closed flask (ca 350 ml), containing 30-40 ml of mercury (Dumarey et al., 1985). The inner pressure is kept at atmospheric pressure by means of a side-arm, which has access to ambient conditions via a capillary. The flask is placed in a thermostat ($20^{\circ}\text{C} \pm 0.1^{\circ}\text{C}$). 0.1 ml saturated air is removed via a septum by using a gas-tight syringe (Hamilton #1810). 0.1 ml of air at 20°C and 101,325 Pa contains 1.316 ng Hg according to Ideal Gas Law (Table 4.8). Its accuracy depends mainly on the temperature of the mercury-saturated air, which must be lower than the ambient temperature to prevent condensation of mercury in the syringe. By preconditioning the syringe, initial irreproducible measurements caused by sorption are avoided. Under optimal conditions the standard deviation of the injection with 0.1 ml ($n=10$) should be better than 10%. The re-establishment of the equilibrium between liquid and gaseous mercury depends on the cleanness of the pool surface. After some time, mercury at the surface becomes oxidised by atmospheric oxygen and the upper layer must be removed.

Table 4.18.1: Concentrations of Hg calibration gas as function of temperature.

Temp °C	ng Hg/ml	Temp °C	Ng Hg/ml	Temp °C	ng Hg/ml	Temp °C	ng Hg/ml
17.0	10.22	20.5	13.72	22.2	15.79	23.9	18.14
18.0	11.12	20.6	13.83	22.3	15.92	24.0	18.29
19.0	12.10	20.7	13.95	22.4	16.05	24.1	18.44
19.1	12.20	20.8	14.06	22.5	16.18	24.2	18.59
19.2	12.31	20.9	14.18	22.6	16.31	24.3	18.74
19.3	12.41	21.0	14.30	22.7	16.45	24.4	18.89
19.4	12.52	21.1	14.42	22.8	16.58	24.5	19.04
19.5	12.62	21.2	14.54	22.9	16.72	24.6	19.20
19.6	12.73	21.3	14.66	23.0	16.86	24.7	19.35
19.7	12.83	21.4	14.78	23.1	17.00	24.8	19.51
19.8	12.94	21.5	14.90	23.2	17.13	24.9	19.67
19.9	13.05	21.6	15.03	23.3	17.28	25.0	19.83
20.0	13.16	21.7	15.15	23.4	17.42	26.0	21.49
20.1	13.27	21.8	15.28	23.5	17.56	27.0	23.27
20.2	13.38	21.9	15.40	23.6	17.70		
20.3	13.49	22.0	15.53	23.7	17.85		
20.4	13.60	22.1	15.66	23.8	17.99		

4.18.2.4 Quality assurance

The necessary quality control steps are primarily associated with gold trap collection and analytical instrument reliability.

All gold traps must be individually calibrated at regular intervals. This is most conveniently done using a source of gaseous mercury, *i.e.* a thermostated vessel containing liquid mercury from which gaseous samples can be drawn with a gas tight syringe. Gold traps with low recovery must be discarded.

To provide an internal control on the field results, one set of 3 or 4 gold traps is routinely kept in the glass container during a field study. The set is then analysed along with the other field samples. In almost all cases, a typical mercury blank result of 5-30 pg Hg was observed.

4.18.2.5 Detection limit

The detection limit of the gold trap analysis is defined as 3 times the standard deviation of the trap blank provided that the trap blank is subtracted from the analysed amount. This detection limit, expressed in units of ng Hg, can be translated into an air concentration using the typical air volume sampled in this application. The detection limit can also be based on the requirement that the blank content of mercury on the traps should not exceed 10% of the total content of mercury collected during a normal sample period. The absolute value will depend on sampling time and air flow rate. As a guideline the following example can be used: in air containing 2 ng Hg/m³ a sample collected for six hours at an air flow rate of 0.5 l/min contains 0.36 ng. In this case, the blank content on the trap

should not exceed 10% of 0.36, i.e. 0.036 ng. If the blank content is higher than this value, then the detection limit exceeds 2 ng/m³ under the conditions employed, and a larger sample volume is required.

4.18.2.6 *Special problems*

The analysis of mercury collected on gold traps is generally straightforward provided that the collection efficiency of the gold traps is checked regularly.

4.18.2.7 *Summary*

	Recommendation	Acceptable alternative
Sample pre-treatment	Drying at 30-50°C if necessary.	
Analysis	Dual amalgamation CVAFS.	CVAAS.
Detection limit	3 σ of trap blank and/or trap blank <10% of sample.	
QA/QC	Check gold trap collection efficiency and recovery.	

4.18.3 *References*

Bloom, N.S. and Creelius, E.A. (1983) Determination of mercury in seawater at subnanogram per litre levels. *Mar. Chem.*, 14, 49-59.

Bloom, N.S. and Fitzgerald, W.F. (1988) Determination of volatile mercury species at the picogram level by low temperature gas chromatography with cold-vapour atomic fluorescence detection. *Anal. Chim. Acta*, 208, 151-161.

Bloom, N.S., Prestbo, E.M., Hall, B. and Von der Geest, E.J. (1995) Determination of atmospheric mercury by collection on iodated carbon, acid digestion and CVAFS detection. *Water, Air, Soil Pollut.* 80, 1315-1318.

Dumarey, R., Temmerman, E., Dams, R. and Hoste, J. (1985) The accuracy of the vapour-injection calibration method for the determination of mercury by amalgamation/cold-vapour atomic absorption spectrometry. *Anal. Chim. Acta*, 170, 337-340.

Ebinghaus, R., Jennings, S.G., Schroeder, W.H., Berg, T., Donaghy, T., Ferrara, R., Guentzel, J., Kenny, D., Kock, H.H., Kvietkus, K., Landing, W., Mazzolai, B., Mühleck, Munthe, J., Prestbo, E.M., Schneeberger, D. Slemr, F., Sommar, J., Urba, A. Wallschläger, D. and Xiao, Z. (1999) International field intercomparison measurements of atmospheric mercury species at Mace Head, Ireland. *Atmos. Environ.*, 33, 3063-3073.

Fitzgerald, W.F. and Gill, G.A. (1979) Subnanogram determination of mercury by two-stage gold amalgamation and gas-phase detection applied to atmospheric analysis. *Anal. Chem.*, 51, 1714-1720.

Iverfeldt, Å. and Sjöberg, K. (1992) Intercomparison of methods for the determination of mercury deposition to convention waters. Göteborg, Swedish Environmental Research Institute (IVL Report B 1082).

Munthe, J. (1996) Guidelines for the sampling and analysis of mercury in air and precipitation. Göteborg, Swedish Environmental Research Institute (IVL-report L 96/204).

OSPAR (1997) JAMP Guidelines for the sampling and analysis of mercury in air and precipitation. London.

Schroeder, W.H., Keeler, G., Kock, H., Roussel, P., Schneeberger, D. and Schaedlion, F. (1995) International field intercomparison of atmospheric mercury measurement methods. *Water, Air, Soil Pollut.*, 80, 611-620.

4.19 Determination of persistent organic pollutants (pesticides and PCBs)

4.19.1 Principle

This method covers the following groups of components:

Chlororganic pesticides:

- α -, β -, and γ -HCH
- HCB
- Chlordanes (including acid labile components)
- DDTs
- The Dieldrin group
- Trifluraline
- α -Endosulphane

Polychlorinated biphenyls,

- PCB

These components may be determined in air samples, described in chapter, [3.13](#). Filter and PUF plugs are extracted separately with a hexane/diethylether 9:1 mixture in a soxhlet extractor. The extracts are concentrated and then cleaned by using adsorption chromatography (silica). After the concentration to the appropriate volume and addition of the recovery standard, the components are separated and quantified by using gas chromatography combined with mass spectrometry (MS).

4.19.2 Materials and equipment

4.19.2.1 Glassware

- Beakers, 50, 100, and 250 ml, Schott Duran or similar
- Desiccator, 150 mm and 300 mm diameter with grinded glass rims, no grease to be applied
- Erlenmeyer flasks, 250 ml with glass stopper
- Funnels, 20 – 150 mm diameter, Schott – Duran or similar
- Sample vials
 - Vial, 0.9 ml, Chromacol 0.9-CTV or similar with septum cap (teflon-coated silicon seal), Brown cat. no.151261 or similar quality
 - Vial, 1.5 ml Brown cat. no.150900 with scew top and teflon seal, Brown cat. no.150931 or similar quality
 - Vial, 2 ml with a capillary opening (diameter 1.5 mm and length 20 mm) and screw cap (teflon seal Schott GL14), (home made)
 - Vial, 8 ml with screw cap (teflon seal), Supelco cat. No. 2-3295
 - vial with 100 μ l insert, Chromacol 0.3- FIV
- Hamilton syringes 5, 10, 25, 100, 250, 500 μ l
- Chromatography column, length 20 cm x 1.5 cm diam., Schott Duran
- Micropipettes, 10, 20, 25, 50 and 100 μ l with accuracy better than ± 0.25 %
- Volumetric flasks, with glass stoppers, and graduated for 10, 25, 50, 100 ml with accuracy better than ± 0.025 %, Schott Duran

- Cylinders, graduated for 25, 50, 100, 250, 500, 1000 ml, with accuracy better than $\pm 0.75\%$, Schott Duran or similar
- Pasteur pipettes 150 mm and 220 mm
- Flasks, round bottom, 100, 250, 500, with glass joints NS24/29, Schott Duran or similar
- Conical glasses for centrifugation, 10 ml
- Soxhlet extractors 200, 500, 2000 ml with condenser, 250 mm, Schott Duran or similar
- Sample tubes for TurboVap 500

4.19.2.2 Other equipment

- Aluminium foil
- Analytical balance, 0–160 g, precision ± 0.0001 g or better
- Cotton wool, chemical clean, (cleaning: section 2.6.4.6)
- Cellulose thimbles for Soxhlet, Schleicher & Schuell (pre-treatment: section 2.6.4.5).
- Gloves, disposable, of polyethylene
- Gloves, solvent resistant, of PE/EVOH/PE laminate
- Freezer for
 - samples, both untreated and extracts after chemical treatment
 - standards
- Evaporator with automatic stop, TurboVap 500, Zymark
- Oven, Hagan, Type 22, 200 - 1030°C, precision $\pm 10^\circ\text{C}$
- Refrigerator, explosion safe, for storing diethyl ether and working standards
- Cork stands in various formats
- Membrane vacuum pumps
- Evaporator to be used with nitrogen gas supply, with activated charcoal cartridge and valve for fine adjustment of nitrogen gas
- Tweezers in various sizes
- Oven, Heraeus, RE 4125, 50–1100°C, $\pm 5^\circ\text{C}$
- Syringes, 5, 10 and 25 μl , fixed needle and steel plunger, Hamilton, and 1 ml, fixed needle and teflon tipped plunger, Hamilton
- Ultrasonic bath, Sonorex RK 100, Bandelieu, 100 W
- Pressure regulator for gas, L'Air Liquide BS 300
- Water purification equipment, MilliQ plus, Millipore
- Heaters for 500 ml spherical flasks
- Oven, 50–300°C with 3°C precision
- Vibrator for dry packing of columns

4.19.2.3 Analytical equipment and accessories

- Gas chromatograph combined with a low resolution mass spectrometer; HP 5890 II gas chromatograph, Hewlett Packard, Avondale, USA
 - HP 5890-II gas chromatograph with split/splitless injector and HP 7673 autosampler
 - HP 5989 mass spectrometer (MS Engine)
 - HP G1034C MS Chemstation integration system

- Gas chromatograph combined with high resolution mass spectrometer VG AutoSpec, MICROMASS, Wythenshawe Manchester, England
 - HP 5890-II gas chromatograph with split/splitless injector and HP 7673 autosampler
 - VG GC/MS interface with lock mass substance inlet system
 - VG AutoSpec three sector high resolution mass spectrometer with EI-ion source
 - EC 3100 data system with OPUS MS- software system
- Examples of GC capillary columns:
 - 60 m and 30 m length* 0.25 mm i.d., 0.10 µm film thickness, 95% dimethyl –5% diphenyl polysiloxane, immobilized, e.g. Rtx-5 from Restek Corporation, Bellefonte, USA
 - 25 m length* 0.20 mm i.d. * 0.11 µm film thickness, 5% phenylmethyl-polysiloxane HP-5 (Ultra), Hewlett Packard Company, Amsterdam, Holland
 - 50 m length *0.22 mm i.d. *0.15 µm 8% phenylpolycarbonsiloxane e.g. HT-8 SGE, Australia
 - 30 m length *0.25 mm i.d. *0.10 µm, 14% cyanopropylphenyl – 86% methylpolysiloxane, immobilized, e.g. Rtx-1701 from Restek Corporation, Bellefonte, USA
 - 30m length *0.25 mm i.d. *0.10 µm, 90% biscyanopropyl 10% phenyl-cyanopropyl, e.g. Rtx-2301 from Restek Corporation, Bellefonte, USA
- GC syringes; Hamilton, 10 µL, fixed needle and metal plunger for HP auto-sampler, HP cat. no. 80397, and for manual injection, cat. no. 80366.

4.19.2.4 Chemicals and gases

Organic solvents

- Acetone, Merck no. 12
- Diethyl ether, Rathburn RG 2013
- Iso-octane, Merck no. 15440
- Methanol, Merck no. 6011
- MS lockmass standard: perfluorokerosene (PFK) low boiling, Merck no. 10145
- n-Hexane, Merck no. 4371
- n-Nonane, Merck no. 806838
- Perfluorotributylamin MS calibration solution, HP cat. No. 0571-60571
- Cyclohexane, Merck no. 2817
- Tetradecane, Fluka no. 87140
- Toluene, Merck no. 8382

All solvents, except diethyl ether can be used without cleaning.

Inorganic chemicals, adsorbents and various accessories

- Active carbon 1.5 mm diameter, Merck no. 2514
- Aluminium oxide, ICN Biomedicals no. 02072 Alumina B, Act. I
- Cotton, Apotekernes Felleskjøp

- De-ionised water, Millipore equipment
- Glass wool, silanized, Alltech cat. no. 4037
- Molecular sieves, 0.5–2 mm, Merck no. 5707, activated at 300°C in a He flow
- Sodium sulphate, Merck no. 6649, heating, see 2.6.4.3
- RBS 25 laboratory detergent, KEBO
- 6 N hydrochloric acid, diluted from concentrated acid, Merck no. 319
- Silica gel, Merck no. 7734, pre-treatment, see 2.6.4.4
- Sulphuric acid, 96%, Merck no. 731

Gases

- Helium, Norsk Hydro 4.5, 99.995%
- Nitrogen, N₂ Norsk Hydro 4.0, 99.99%
- Methane, CH₄ 3.5, Messer Griesheim, 99.9%

4.19.3 Cleaning and pre-treatment

4.19.3.1 Cleaning of the sampler

See chapter [3.16.3.1](#)

4.19.3.2 Cleaning of PUF-plugs

See chapter [3.16.3.2](#)

4.19.3.3 Cleaning of glass equipment

See chapter [3.16.3.3](#)

4.19.3.4 Cleaning of other equipment

See chapter [3.16.3.4](#)

4.19.3.5 Check and pre-treatment of solvents and chemicals

All solvents must be of "pesticide grade" or equivalent quality. The solvent must give chromatograms free from interfering peaks ($S/N < 3$) in the elution range from α -HCH to OCN. Performing a complete method blank test may also check this.

4.19.3.6 Cleaning of diethyl ether

The diethyl ether must be cleaned because it contains an inhibitor to prevent formation of peroxides: 250 ml diethyl ether is filtered using a chromatography column (diam. 20 mm) packed with 20 cm basic aluminiumoxide. Diethyl ether without inhibitor may, with time, form peroxides, which represents an explosion hazard, especially by pre-concentrating samples using a rotary evaporator. Therefore not more than an amount sufficient for one month's consumption is cleaned. The solvent is stored in the dark at a temperature $< 5^{\circ}\text{C}$.

4.19.3.7 Pre-treatment of sodium sulphate

Sodium sulphate is put in a porcelain dish and heated to 600°C for 8 hours in an oven. Let cool to room temperature in a desiccator. Store in a stoppered glass

bottle. The bottle must be labelled with the expiry date of the sodium sulphate. Maximum storage time is one month. After the expiry date the sodium sulphate is discarded.

4.19.3.8 Pre-treatment of silica

Ca. 400 g silica is put in a porcelain dish and heated at 600°C for at least 8 hours in an oven. After heating the silica is left to cool in a desiccator and shall not be used before it has reached room temperature. The silica is stored in a glass bottle with a glass stopper. The bottle must be labelled with the expiry date of the silica. Maximum storage time is one month

4.19.3.9 Cleaning of soxhlet thimbles

Soxhlet thimbles are cleaned by soxhlet extraction using n-hexane for 8 hours. The thimbles are dried in a fume hood at room temperature overnight and wrapped individually in aluminium foil.

4.19.3.10 Cleaning of cotton wool

Cotton wool is soxhlet extracted with 500 ml – 2500 ml (depending of amount of cotton) n-hexane or dichloromethane for 24 hours. The cotton is dried in a vacuum desiccator at 60°C.

4.19.4 Gas cleaning

4.19.4.1 Gas bottle exchange

1. Gas bottles must be replaced when the pressure approach 20 bar. The bottle pressure should never be lower than 15 bar.
2. Before exchanging GC-carrier gas bottles, set GC-oven temperature below 50°C.
3. Bottle exchange should be performed rapidly. Collect the new bottle before disconnecting the old one.
4. If only one spare bottle is in the storage room, order a new batch.
5. Flush the bottle valve on the new bottle twice (ear protection) before connecting the pressure reduction valve.
6. Connect pressure reduction valve firmly and open it.
7. Check for leaks with leak detector (Ion Sciences: Gas Check B4 or Supelco: Snoop leak detector).
8. Mount valve protection cap on the empty bottle and transport the bottle to the storage room.
9. All bottles must be secured against falling over.

4.19.5 Special procedures

Helium GC carrier gas cleaning:

1. Chrompack Gas Clean Oxygen Filter (with charcoal) and Chrompack Gas Clean Moisture Filter are connected in series after the pressure reduction valve. Exchange the units after exchanging 5 bottles or once a year.
2. Two metal cartridges are mounted in series on the gas line before each GC inlet. The first is filled with active carbon, the second is filled with molecular sieves. Exchange adsorbents each 3 years and after irregularities (empty gas bottle).

Nitrogen used for final sample blow-down/pre-concentration is cleaned using a metal cartridge filled with active carbon. Exchange adsorbent when exchanging the gas bottle.

4.19.6 Treatment of adsorbents

Chrompack filters are discarded after use.

Re-activation of molecular sieves: Fill molecular sieves in a metal cartridge and activate at 300°C (3 h) in an oven, flushing the cartridge with 20 ml/min. pre-filtered helium.

Active carbon is discarded after use.

4.19.7 Sample preparation

Sample pre-treatment, e.g. weighing of filters and extraction, is discussed in chapter [3.17.5](#)

4.19.7.1 Principle

Small amounts of interfering substances may be removed from the sample with one single method. Depending on the components to be measured different cleaning procedures can be selected; treatment of the extract with sulphuric acid for acid-stable components, or with alkaline hydrolysis for acid-labile substances. Both treatments are followed by adsorption chromatography. When both acid-stable and -labile substances are measured and their relative amounts unknown, the concentrate should be divided into two equal parts before further treatment. After cleaning, the sample should be concentrated once more followed by addition of a recovery standard (TCN or OCN) in order to determine the amount of internal standard before the sample is ready for analysis by GC/MS.

4.19.7.2 Sulphuric acid treatment of acid-stable substances

The concentrated sample (0.5–1 ml volume) is transferred to a 10–15 ml centrifuge tube, 8-10 ml conc. sulphuric acid added, and placed in a rack until the next day. The hexane fraction is transferred to a new centrifuge tube and 1 ml MilliQ water added drop by drop. The water phase is removed and the hexane phase dried with ½ teaspoon Na₂SO₄.

4.19.7.3 Alkaline hydrolysis of acid-labile substances

To 1 ml concentrated sample is added a solution of 0.2 g KOH in 1 ml ethanol and 0.1 ml MilliQ water. The mix is heated on a water bath at 50°C for 30 min. Add 5 ml MilliQ water, shake the sample, separate by a centrifuge, concentrate the organic phase by evaporation, and add a recovery standard before the GS/MS analysis. If the hydrolysed sample is strongly coloured after evaporation, the sample may be cleaned using silica-chromatography (next Section).

4.19.7.4 Silica chromatography

Cotton is put at the bottom end of a glass column (20 cm x 1.5 cm) and the column is filled with 4 g silica activated at 600°C. A layer of 1g Na₂SO₄ is added on top. Use a vibrator when filling. The column is washed with 30 ml 10 % diethyl ether in hexane. The column should never be allowed to run dry! The sample (0.5–1 ml volume) is transferred to the column after washing, and the sample container rinsed with additionally 2–3 ml diethyl ether/hexane mixture which is transferred to the column. Elute the column with 30 ml of diethyl ether/hexane mixture and the sample is collected in a TurboVap glass with 20 µl nonane as a keeper. The sample volume is carefully reduced with the TurboVap until 0.5 ml, and transferred to a sample glass with conical insert. The TurboVap vessel is rinsed three times with 0.15 ml hexane, and the liquid volumes added to the sample. The sample volume is reduced to the desired volume (0.1–0.5 ml) in a slow nitrogen stream. Recovery standard is added and the sample vessel sealed with a screw cap or a crimp cap with auto-injector septum. This sample is now ready for a GS/MS analysis. If the sample is not analysed at once (same day) it must be kept dark in a freezer at -20°C. If the sample is stored for more than 1 month, this should be noted in the data report.

4.19.7.5 If the sample contains silica particles

Flush a pasteur pipette with a piece of cotton wool at the bottom with hexane. Pass the sample through the pipette and collect the sample. Wash with a small amount hexane before volume reduction to 0.1–0.5 ml.

4.19.8 Standards

A standard mixture containing known concentrations of components of interest is used for identification/quantification. Standard components should preferably be provided as crystalline solids with purity better than 99 per cent. If they can be provided in solutions only, the solutions must be certified or calibrated against certified standards from an international standardisation bureau as NIST or BCR.

Concentrated standards containing only one, or a small number of components are prepared and checked by GC/MS in full scan mode before further use. If impurities are discovered, their concentrations should correspond to less than 3% of the main components area. The other standards; calibration standards, internal standards, and recovery standards, are all prepared as different diluted mixtures based on the concentrated standards.

Weighing the proper amounts of crystalline substance of the standards should be performed with great care. Use disposable gloves and a mask. Weighing ships and spatulas should be rinsed in toluene and hexane before use and (air) dried. The tare of the ship is set to zero and the standard component transferred to the ship by a thin spatula in an amount as close to the estimated one as possible. The spatula must be rinsed and dried between each weighing in order to avoid contamination. When all components have been weighed, the content of the ship is transferred to a volumetric flask with n-hexane or iso-octane. The flask is filled with n-hexane or iso-octane to the correct volume and placed in an ultrasonic bath until all solids are dissolved. The concentrated standard is transferred to a flask equipped with screw cap and a teflon seal.

The weighed amounts and standard concentrations, a standard number, and the weight of the standard flask must be recorded in the standards logbook. The concentrated standards should be kept in a refrigerator at 4°C. When preparing the more diluted solutions, the concentrated standards should be removed from the fridge two hours before use. The concentrated standard should be sonicated for 5 min. in order to dissolve any solid substance. This is of particular importance for heavily soluble components e.g. β -HCH. In order to maintain a high accuracy in the final concentration, the dilution should be less than 1:100 in all steps, i.e. at most 100 μ l in a 10 ml graduated flask. When more diluted solutions are needed, secondary standards should be prepared. The flask containing the concentrated standard should be weighed before and after removing a volume for dilution, and the weights recorded in the logbook.

Diluted solutions are prepared by using volumetric flasks and pipettes or syringes. Disposable pipettes are preferred to syringes used for different standards because of a possibility for contamination. The entire dilution process must be checked by weighing.

4.19.8.1 Concentrated standard

The following components may be included in a set of standards:

Pesticides	Abbreviation	Polychlorinated biphenyls	IUPAC no.
Hexachlorobenzene	HCB	2,2',5'-TriCB	18
α -Hexachlorocyclohexane	α -HCH	2,4,4'-TriCB	28
β -Hexachlorocyclohexane	β -HCH	2,4',5'-TriCB	31
		2',3,4'-TriCB	33
		3,4,4'-TriCB	37
γ -Hexachlorocyclohexane	γ -HCH	2,2',4,4'-TetCB	47
Trifluralin	Trifl	2,2',5,5'-TetCB	52
Chlordene	CDen	2,3,4,4'-TetCB	60
Heptachlor	HepC	2,3',4,4'-TetCB	66
Oxy-Chlordane	oxy-CD	2,4,4',5'-TetCB	74
Cis-Heptachlorepoxyde	cis-Hepex	2,2',4,4',5'-PenCB	99
Trans-Chlordane	tr-CD	2,2',4,5,5'-PenCB	101
Cis-Chlordane	cis-CD	2,3,3',4,4'-PenCB	105
trans-Nonachlor	tr-NO	2,3,4,4',5'-PenCB	114
cis-Nonachlor	cis-NO	2,3',4,4',5'-PenCB	118
Pesticides	Abbreviation	Polychlorinated biphenyls	IUPAC no.
		2',3,3',4,5'-PenCB	122
α -Endosulfan	α -Endo	2',3,4,4',5'-PenCB	123
Dieldrin	Diel	2,2',3,3',4,4'-HexCB	128
Aldrin	Ald	2,2',3,4,4',5'-HexCB	138
		2,2',3,4,5,5'-HexCBC	141
Endrin	End	2,2',3,4',5',6'-HexCB	149
o,p'-Dichlorodipenyldichloroethane	op-DDD	2,2',4,4',5,5'-HexCB	153
p,p'-Dichlorodipenyldichloroethane	pp-DDD	2,3,3',4,4',5'-HexCB	156
o,p'-Dichlorodipenyldichloroethylene	op-DDE	2,3,3',4,4',5'-HexCB	157
p,p'-Dichlorodipenyldichloroethylene	pp-DDE	2,3',4,4',5,5'-HexCB	167
Pesticides	Abbreviation	Polychlorinated biphenyls	IUPAC no.
o,p'-Diklorodifenyltrikloroethane	op-DDT	2,2',3,3',4,4',5'-HepCB	170
p,p'-Diklorodifenyltrikloroethane	pp-DDT	2,2',3,4,4',5,5'-HepCB	180
		2,2',3,4,4',5',6'-HepCB	183
		2,2',3,4',5,5',6'-HepCB	187
		2,3,3',4,4',5,5'-HepCB	189
		2,2',3,3',4,4',5,5'-OctCB	194
		2,2',3,3',4,4',5,5',6'-NonCB	206
		2,2',3,3',4,4',5,5',6,6'-DecaCB	209
Internal standard pesticides	Abbreviation	Internal standards PCB	IUPAC no.
^{13}C -p,p'-Dichlorodipenyldichloroethylene	^{13}C -p,p'-DDE	^{13}C -2,4,4'-Trichlorobiphe	^{13}C -PCB-28
^{13}C - γ -Heksachlorosyklohexane	^{13}C -2D- γ -HCH	^{13}C -2,2',5,5'-Tetrachlorobiphe	^{13}C -PCB-52
^{13}C - α -Heksachlorosyklohexane	^{13}C - α -HCH	^{13}C -2,2',4,5,5'-Pentachlorobiphe	^{13}C -PCB-101
		^{13}C -2,3',4,4',5'-Pentachlorobiphe	^{13}C -PCB-118
		^{13}C -2,2',4,4',5,5'-Hexachlorobiphe	^{13}C -PCB-153
$^{13}\text{C}_4$ -Aldrin			
$^{13}\text{C}_4$ -Dieldrin			
$^{13}\text{C}_4$ -Heptachlor			
^{13}C -Hexachlorobenzene	^{13}C -HCB	^{13}C -2,2',3,4,4',5,5'-Heptachlorobiphenyl	^{13}C -PCB-180
Recovery standards			
1,2,3,4-Tetrachloronaphtalene	TCN		
Octachloronaphtalene	OCN		

4.19.8.2 Calibration standard

A standard for GC/MS should have concentrations similar to the expected concentrations of the components to be measured

4.19.8.3 Internal standard (ISTD)

The internal standard may be a solution with pesticides and/or PCBs which contains labelled isotopes.

4.19.8.4 Recovery standard (RSTD)

A solution containing tetrachloronaphtalene is used for this purpose. The recovery standard is added to the sample as the last step before quantification.

4.19.8.5 Standard addition

Amounts of standards added before extraction (ISTD) and after the sample preparation (RSTD) should be similar to the expected concentrations in the sample.

4.19.8.6 Quality assurance of standards

The purity of the standards is checked in the GC/MS full scan mode before acceptance. If impurities are discovered in the concentrated standard, the amounts as expressed by its area in the chromatogram must be less than 3 % of the main component's area. When concentrated standards are stored dark in a refrigerator, their stability will be very good. In order to document the stability, the full scan mode check is repeated at intervals not longer than 3 years. Normally this will be carried out when preparing a working standard after 2 years. The working standards are stored dark in a refrigerator, but new standards should be prepared every two years at most. Working standards kept in sample flasks with capillary tubes are not checked for weight loss (1 mg in 6 months when closed). The stability of working standards stored as described above is considered to be 2 years.

A newly prepared series of standards must always be compared with the previously used ones before use. Only differences considered to be less than the reproducibility of the analytical method are accepted. The working standards should be compared with certified reference material; NIST SRM 1492 "Chlorinated pesticides in hexane" and BCR CRM 365 "Polychlorinated biphenyls in iso-octane", at least once every year. Standards from laboratory comparisons may also be used. The standards should be stored in a refrigerator.

4.19.9 Separation and quantification

4.19.9.1 Principle

The cleaned samples are analysed by gas chromatography/mass spectrometry (GC/MS). Standard mixtures are used for identification and quantification.

The individual components are identified by their GC retention and their mass fragments.

The quantification of the components is made by using internal standard. A calibration is performed with a standard mixture containing known concentrations of the components to be measured and one or more components not contained in the sample (internal standards). The calibration is followed by injection of the sample containing known amounts of internal standards. Quantification is relative to the internal standard. In this way, the sample extract volume will not be included in the calculations, and it is not necessary to accurately determine the final sample volume after evaporation or the injection volume.

4.19.9.2 Gas chromatographic conditions

The GC-parameters given are approximate and must be fine-tuned for each column, since equal columns may separate the actual compounds slightly differently.

Capillary column: Rtx-5, 60 m x 0.25 mm x 0.10 μm :

Carrier gas: He, 185 kPa (1.85 bar, 27 psi)

GC-temperature program:

1 μl injected splitless (autoinjector or "hot needle" injection) at 60°C, 2 min. at 60°C, 60–190°C with 20°/min., 190–230°C with 3°/min., 230–280°C and 280°C for 15 min. isothermally.

Capillary column: Rtx-5 or equivalent, 30 m x 0.25 mm x 0.10 μm :

Carrier gas: He, 75 kPa (0.75 bar, 11.5 psi)

GC-temperature program:

1 μl injected splitless (autoinjector or "hot needle" injection) at 60°C, 2 min. at 60°C, 60–150°C with 20 °/min., 150–280°C with 1 °/min. and 280°C for 10 min. isothermally.

Capillary column: Rtx-2330 or equivalent, 30 m x 0.25 mm x 0.10 μm :

Carrier gas: He, 83 kPa (0.83 bar, 12 psi)

GC-temperature program:

1 μl injected splitless (autoinjector or "hot needle" injection) at 60 or 100°C (depending on solvent), 2 min. at 60 or 100°C (depending on solvent), to 170°C with 20 °/min., 170–230°C with 3 °/min., 230–270°C and 270°C for 6.5 min. isothermally.

Capillary column: HP Ultra-2, 25 m x 0.20 mm x 0.11 μm :

Carrier gas: He, 110 kPa (1.1 bar, 15 psi)

GC-temperature program:

1 μl injected splitless (autoinjector or "hot needle" injection) at 60°C, 2 min. at 60°C, 60–150°C with 20 °/min., 150–230°C with 4 °/min. and 230–280 with 25 C/min and 275°C for 5 min. isothermally.

In addition the following parameters are used:

Split gas flow: 40 ± 10 ml/min
Septum purge flow: 3 ml/min
Injector temperature: 260°C
GC/MS-interface temperature: 260°C–280°C

To save carrier gas, the split gas flow is reduced to <5 ml/min when the instrument is not used.

Autoinjector conditions (approximate):

Solvent A: toluene
Solvent B: n-hexane
Sample wash: 0
Sample pumps: 5
Sample volume: 1 μ l
Solvent A washes: 8
Solvent B washes: 8

Solvents A and B for syringe cleaning must be exchanged each day. The solvent vials are cleaned when necessary.

The injector septum is exchanged after ca. 50 injections or once a week. The cleanness of the glass liner is checked after ca. 100 injections or if the GC-separation is poor.

4.19.9.3 GC/MS-analysis

For quantification GC/MS with either EI or NCI ionisation is used. To check the stability of the GC/MS-system, a calibration standard is injected before and after each sample batch.

Operation of the GC/MS-system is described in the instrument manuals.

Calibration- and detection conditions for EI (VG-AUTOSPEC GC/MS)

Gas chromatograph
GC/MS-interface: 260°C
Ion source:
Electron impact (EI) ion source
Ion source temperature: 260-300°C
Max. acceleration voltage: 8000 V
Electron energy: 30 eV-40 eV
Lock substance: Perfluorokerosene (PFK)

By mounting the capillary column, 1-2 mm of the exit of the column (on the MS-side) should extend into the ion source.

Using mass fragment $m/z = 330,97$ from perfluorokerosene (PFK, boiling point range 70°–240°C) the instrument is optimised manually for ion gain and mass

resolution. At resolution 10,000 (defined as $m/\Delta m = 10,000$ at 5% valley) the signal/noise ratio for 500 fg of γ -HCH should be $S/N \geq 3$.

The mass scale for each SIM-function (single ion monitoring) is calibrated automatically if possible. Optimisation of ion source and mass resolution and calibration of mass scale is controlled for each single PFK-mass in each SIM-function.

To reduce the risk of false identification further, two masses in each fragment cluster are detected (see table SIM-program for pesticides).

The SIM-program described is sufficient for a semi-quantitative analysis. If a higher accuracy is desired, a ^{13}C -labelled internal standard must be added to each SIM-group in order to compensate for differences in sensitivity between the different SIM-functions.

Since the mass spectrometer has a large linear range, injection of one calibration standard before a series of samples is sufficient.

Calibration

The response factor, Rf_i , for each compound, i , relative to the internal standard (*ISTD*) is determined from an analysis of a calibration standard with known concentrations:

$$Amount_i = \frac{Amount_{ISTD} \times Area_i}{Rf_i \times Area_{ISTD}}$$

Rf_i :	Response factor of compound i
$Amount_{ISTD}$:	Amount of internal standard injected
$Amount_i$:	Amount of compound i injected
$Area_i$:	Peak area of compound i
$Area_{ISTD}$:	Peak area of internal standard

Quantification

Using the response factors, Rf_i , determined during the calibration, a known amount of internal standard and the peak areas detected during the quantitative analysis, the amount of each compound i is calculated.

$$Amount_i = \frac{Amount_{ISTD} \times Area_i}{Rf_i \times Area_{ISTD}}$$

$Amount_i$:	Amount of compound i in the sample
$Amount_{ISTD}$:	Amount of internal standard added to the sample
$Area_i$:	Area of compound i
Rf_i :	Response factor of compound i
$Area_{ISTD}$:	Area of internal standard

Recovery of internal standard (added before sample clean-up) is computed relative to amount of recovery standard (RSTD) added before the quantification. Relative response factors based on the recovery standard (RRF_g) is calculated for each ISTD-compound from the quantification standard analysis.

$$RRF_g = \frac{Amt._{RSTD} \cdot Area_{ISTD}}{Amt._{ISTD} \cdot Area_{RSTD}}$$

$$Rec.(%)_{ISTD} = \frac{Amt._{RSTD} \cdot Area_{ISTD} \cdot 100}{RRF_g \cdot Amt._{ISTD} \cdot Area_{RSTD}}$$

- $Amt._{ISTD}$: Amount internal standard added before extraction
 $Amt._{RSTD}$: Amount of recovery standard added before quantification
 $Area_{ISTD}$: Peak area of internal standard
 $Area_{RSTD}$: Peak area of recovery standard

SIM-program for PCB-compounds

SIM-function	Isomer group	¹² C-Mass 1	¹² C-Mass 2	¹³ C-Mass 1	¹³ C-Mass 2
1	HCB PFK	283,8102 292,9825	285,8072	293,8244	295,8214
2	TCN TrCB TeCB PFK	263,9067 255,9613 289,9224 280,9825	265,9038 257,9584 291,9194	268,0016 301,9226	269,9986 303,9597
3	TeCB PeCB PFK	289,9224 325,8804 342,9792	291,9194 327,8775	337,9207	339,9177
4	PeCB HxCB HpCB PFK	325,8804 359,8415 393,8025 342,9792	327,8775 361,8385 395,7995	337,9207 371,8817	339,9177 373,8788
5	HxCB HpCB PFK	359,8415 393,8025 380,9760	361,8385 395,7995	405,8428	407,8398

SIM-program for DDT-compounds

SIM-function	Isomer group	¹² C-Mass 1	¹² C-Mass 2	¹³ C-Mass 1	¹³ C-Mass 2
1	TCN PFTBA DDE DDD DDT DDT(control)	263,907 218,986 246,000 235,008 235,008 246,000	265,904 247,997 237,005 237,005 247,997	258,041	260,038

All mass fragmentograms and area lists are printed after the analysis. Mass fragmentograms must be evaluated on the following properties:

- Clean undisturbed mass fragmentograms, missing or extra signals?
- Sufficient gas chromatographic separation?
- Correct retention times: deviation of relative retention time relative to OCN retention time shall be less than ± 3 sec.
- Intensity ratio: the area ratio of mass 1 to mass 2 for each compound is calculated. The deviation shall be less than 20% relative to the theoretical value
- Signal/noise ratio sufficient? $S/N > 3$

Calibration- detection conditions for NCI (HP 5989 GC/MS)

- Gas chromatograph: see 2.4
- GC/MS-interface: 260°C

- Ion source:
- CI ion source
- Ion source temperature: 200°C
- Electron energy: 90-150 eV
- CI-gas pressure 0.4-0.6 torr (approximate values)
- CI-gas: Methane

The instrument parameters are optimised using perfluorotributylamine (PFTBA) either with automatic or manual tuning. To reduce the risk of false identification further, two masses (M and M+2) in each fragment cluster are detected (see table for SIM-program).

Since the mass spectrometer has a large linear range, injection of one calibration standard before a series of samples is sufficient. The analysis is performed using the same procedures described for EI GC/MS.

All mass fragmentograms and area lists are printed after the analysis.

SIM-program for POP (for guidance)

SIM-function	Isomer group	Mass 1	Mass 2
1	HCH	252.9	254.9
	¹³ C-HCH	262.9	264.9
	Chlordene	263.9	265.9
	¹³ C- ² D-HCH	264.9	266.9
	HCB	282.8	284.8
	¹³ C-HCB	295.8	297.8
	Trifluralin	335.1	336.1
	Heptachlor	299.8	301.8
2	TCN	263.9	265.9
	Aldrin	329.9	331.9
	Oksychlordane	349.8	351.8
	Heptachlorepoxyde	387.8	389.8
	Trans-Chlordane	407.8	409.8
3	o,p-DDE	245.9	247.9
	PCB 101, PCB-118	325.9	327.9
	¹³ C-PCB-118	337.9	339.9
	Dieldrin, Endrin	379.9	381.9
	α-Endosulfane	405.8	407.8
	cis-Chlordane	407.8	409.8
	trans-Nonachlor	441.8	443.8
4	o,p-DDD	245.9	247.9
	p,p-DDE	315.9	317.9
	PCB 105	325.9	327.9
	PCB-153	359.8	361.8
	¹³ C-PCB 153	371.8	373.8
	cis-Nonachlor	441.8	443.8
5	p,p-DDT	280.9	282.9
	PCB 138	359.8	361.8
	PCB 156	359.8	361.8
6	PCB 156	359.8	361.8
	PCB 180	393.8	395.8
	OCN	401.7	403.7
	¹³ C-PCB 180	405.8	407.8

4.19.10 Calibration of instruments

The GC/MS-instrument should be calibrated every day. The sensitivity of the mass spectrometer can, for instance, be controlled daily by determining the signal-to-noise ratio for a given amount of a chosen component (one such component could be PCB-101).

4.19.10.1 Control of concentrations of standards

Every new working standard should be compared to the existing standard before it is taken into use. Deviations within the reproducibility of the procedure are acceptable. At least once a year, the working standards should be controlled against a reference standard from an intercomparison or which has been certified from an international reference laboratory.

The accuracy should be within the uncertainty of the procedure ($\pm 20\%$). Measures to assure constant standard concentration is described in chapter [4.19.8.2](#) under "Quality assurance of standards".

4.19.10.2 Frequency of GC injections of quantification standard

The quantification standard should be injected at the beginning of the GC-run of every series of samples. A maximum of 10 samples should be analysed before a new injection of the quantification standard is carried out. If the sample series consists of less than 10 samples, the quantification standard should be injected after the last sample. A control standard should also be injected with every sample series.

4.19.10.3 Analysis of control samples

At the moment there is no certified reference material available that can be utilised for determination of organic compounds in air samples. It is therefore necessary for the laboratory to establish a control sample. This sample should be large enough to correspond to about 40 real air samples. The sample is extracted in the usual way. The extract is homogenised and split into 40 separate samples that are stored in suitable flasks at -20°C . Each year, at least 4 of these control samples should be analysed. The results for at least one component from each component group (for instance γ -HCH, tr-CD and PCB-153) should be plotted on a quality control chart (QCC, Vogelsang, 1991). This quality control chart gives a good overview of the long time stability of the measurement results.

4.19.11 Recovery test

An internal standard (ISTD) should be added at the beginning of the procedure and a recovery standard (e.g. octachloronaphtalene) should be added just before the quantification step. In addition to this, recovery tests with spiked (including C^{12} -components) samples or solvents should be carried out for every 100 sample of a certain type. In this work, analysis of control samples and blank samples are also important parts. The recovery of the internal standard should be between 40% and 120%, while the spiked C^{12} -components should have a recovery that corresponds to the uncertainty of the procedure (for instance $\pm 20\%$) relative to the theoretically added amount of each component. For volatile components, for instance HCB or HCH, which are prone to losses during the volume reducing steps, the lower recovery limit for the corresponding C^{13} -spiked components are 20%.

4.19.12 Quality assurance

4.19.12.1 General principles

The aim of quality assurance (QA) is to ascertain that the established results have the necessary accuracy and traceability.

The methods used for determination of organic compounds in environmental samples at very low concentrations may include a number of possibilities for errors:

- Loss and contamination during or after sampling or during sample preparation

- Reactions or breakdown after sampling
- Interferences
- Errors in detection or quantification due to a large and partially unknown number of organic compounds in various sample matrixes
- Errors in instrumentation or operator errors

To eliminate as many as possible of these error sources, the following demands should be fulfilled:

1. The laboratory personnel must have adequate competence and everyone involved must be familiar with the detailed routines
2. Equipment, chemicals and other materials should be well suited for their purpose. The quality should be regularly controlled and documented
3. The operating procedures should fit the purpose, be validated and adequately documented
4. Every working step and routine should be described
5. The results should be completely traceable

4.19.12.2 Administrative routines

Operating procedures

The operating procedures are the fundament for every quality assurance measure taken. The procedures assure continuity and dependability in every working step carried out in the laboratory. They are also an important part of the education and training of new operators and of the continuous training of all personnel involved. The operating procedures should include descriptions and specifications of the following:

- Every working step and routine and all equipment, chemicals and instruments used from sampling to reporting
- Validation methods used (how to specify the "trueness" of the results)
- Calibration of instruments
- Handling of reference materials and working standards
- Administrative routines that should be followed. Examples are sample journal, sample handling form, reporting and storage

4.19.12.3 Sample journal

As soon as the laboratory receives a sample, the sample should be registered in the sample journal or sample logbook. The journal should include information about sample type, sampling site, sampling date, sample amount, and, if necessary, place of storage. Every sample should be given a unique sample number, for instance year/serial number (99/102).

4.19.12.4 Sample handling form

When the sample is registered in the sample journal a sample handling form for the sample should be established. In addition to information about sample type, sample number and so on, details of the important steps in the sample handling should be written on the form, especially deviations from the procedures.

Amounts of added standards and name and location of electronic data files should also be specified. All notes in the form should be signed (initials) and dated.

4.19.12.5 Instrument logbook

Every analysis instrument should have an instrument logbook. In this journal every sample run should be registered together with method used, temperature program or other vital instrument parameters. Instrument deviations, for instance poor separation or “tailing”, should be registered. In addition, instrument sensitivity and simple maintenance of the instrument, e.g. change of septum or cleaning of the glass liner, should be registered.

4.19.12.6 Standard journal

Every standard should be given a unique identification. The standards should be registered in the standard journal. Concentration, solvent, date of preparation and weight of the container should be specified. A container should be weighed at room temperature before and after removal of an amount of standard. Weight and date should be registered in the journal. It is not necessary to weigh a working standard in a glass container with capillary outlet.

4.19.12.7 Acceptance of results

The following criteria should be fulfilled in order to achieve a necessary degree of certainty in the identification and quantification of organic compounds:

- Blank values should correspond to the limit of detection or alternatively be less than 1/10 of the lowest concentration expected (for samples from background areas, for instance the Arctic, the blank values should be less than 1/5 of the lowest expected concentration). Alternatively, if the series contains more than 5 blank samples, the limit of quantification can be defined as the average of the blank values plus 3 standard deviations.
- Calibration: Special adjustments in multilevel calibrations should be controlled.
- Identification and quantification:
 - Are the mass fragmentograms pure and undisturbed or are there extra or missing signals?
 - Is the gas chromatographic separation adequate?
 - Retention times: Deviations in the relative retention times in relation to the isotopic marked quantification standards should be between +3 and 0 seconds. The deviation relative to non-isotopic marked quantification standards should be between +2 and -2 seconds.
 - The signal-to-noise ratio should be larger than 3:1.
 - The ratio between two measured isotope signals should be inside $\pm 20\%$ of the theoretical value (alternatively the standard value).

4.19.12.8 Reporting of results

The report should include:

- Sample identification, sample type and amount

- Operating procedure and detection and quantification method
- Results with limit of detection
- Measurement uncertainty

4.19.12.9 Storage

The following should be stored:

- Sample handling form, sample journal, instrument journal, standard journal and reports should be stored for at least 5 years
- Data files should be saved on an adequate medium for 5 years

It is not necessary to store paper copies of chromatograms or fragmentograms

4.19.12.10 Validation of the method

There are always a number of possible errors that may affect the quality of the results. It is not possible to eliminate all these errors because samples are different due to a number of factors and because every step in the procedure has inherent possibilities for errors. Validation of a method must therefore be a continuous process.

The following is a list of some of the more important possible errors with measures or control routines:

1. Loss after sampling: Every sample should be wrapped adequately, for instance in aluminium foil and plastic bags with zip locks, and transported to the laboratory as soon as possible. If samples must be stored, they should be kept in the dark. Air samples should be stored at -20°C .
2. Loss during sample preparation and clean-up
3. Contamination during sampling, storing or sample preparation and clean-up: See chapter 4.19.10. "Testing of blank values".
4. A large number of partially unidentified organic compounds (sample matrix) are complicating the determination of organic compounds in air samples. It is not always possible to remove these organic compounds (or sample matrix) completely and in some cases this may give rise to interferences or faulty identifications (see chapter 5.3.2).

4.19.12.11 Testing of blank values

An important part of the quality control of the results is the comparison of the measured sample concentration with the blank values of the method (calculated on the basis of the sample amount). Before the preparation and clean-up of every new series of samples or new sample type is started, a blank sample should be run through the procedure. The result for this sample will represent the blank value of the method.

In the case of larger series of the same type of samples, it will be enough to run a blank sample (filter and PUFs) for every 30 real sample unless there are other considerations that make it necessary with more frequent blank samples. One such

consideration is the analysis of a sample with unexpected high concentration (more than 100 times above the normal level). A blank field sample (representing the blank value of the whole process including sampling, transport and preparation and clean-up) should be run 2 to 3 times a year for each sampling site.

Criteria for acceptance of blank values

The results of a blank sample is accepted if the blank values for every component to be quantified is lower than the limit of detection (signal-to-noise ratio larger than 3:1) or at lower than 1/10 of the lowest expected concentration level. For a larger blank sample series (more than 5 blank samples) the limit of quantification may be utilised. This level of quantification is defined as the average of the blank value (for a component) plus 3 standard deviations.

4.19.12.12 Participation in laboratory intercomparisons

Intercomparisons are an important tool for validating the operating procedure. The laboratory should try to achieve participation in at least one intercomparison a year for each sample type (air, precipitation, sediment and biological samples).

4.19.13 Reference

Vogelsang, J. (1991) The quality control chart principle: Application to the routine analysis of pesticide residues in air. *Fresenius J. Anal. Chem.*, 340, 384-388.

4.20 Determination of polycyclic aromatic hydrocarbons (PAHs) in air

4.20.1 Introduction

Sampling is performed using a high volume sampler. Particle bound polycyclic aromatic hydrocarbons (PAHs) are collected on a glass fibre filter, and more volatile PAHs are adsorbed to plugs of polyurethane foam (PUF) placed behind the filter. The filter and the plugs are Soxhlet extracted with cyclohexane after sampling. The pre-concentrated extracts are cleaned using liquid/liquid extraction and HPLC before analysis using high resolution gas chromatography combined with mass spectrometry (GC/MS).

4.20.2 Equipment and instruments

4.20.2.1 Gas chromatography/mass spectrometry (GC/MS)

Autosampler	:	Hewlett-Packard 7673 or similar
Detector	:	Hewlett-Packard 5970 Mass Selective Detector (MSD), 5973 MSD or similar
Gas chromatography	:	Hewlett-Packard 5890 or similar with splitless injector
GC-column	:	Capillary column, 25-30 m x 0.25 mm, CP-Sil 8CB, SE 52 or similar, 0.1 µm film thickness.
Integrator system	:	Hewlett-Packard Pascal 3.2 ChemStation or similar

4.20.2.2 Liquid chromatograph

Injector	:	Rheodyne 7125 with 2 ml sample loop
Column	:	Lichrosorb Si-60-5, 5 µm, 4.6 mm x 25 cm
Pump	:	LDC Constametric model III
Syringe	:	1000 µl, Hamilton no. 1001
UV-detector	:	LDC UVIII monitor model 1203
Valve for switching solvent	:	Hamilton no. 86414

4.20.2.3 Soxhlet equipment

Extractors	:	60 ml, male glass joint 24/29 and female glass joint 34/35 500 ml, male glass joint 24/29 and female glass joint 60/48 2000 ml, male glass joint 34/35 with flat lid, size 34/35
Extraction timbles	:	28 x 80 mm, cellulose, Schleicher & Schuell 53 x 145 mm, cellulose, Schleicher & Schuell 60 x 180 mm, cellulose, Schleicher & Schuell
Coolers	:	double surface, 345 mm long with male glass joint 34/35 cooler, 260 mm long with male glass joint 34/35 cooler, 330 mm long with male glass joint 24/29
Connector	:	female glass joint 34/35 to male glass joint 60/48

4.20.2.4 Glass equipment

Desiccator	:	internal diam. 30 cm, lid with vacuum connection
Micro pipettes	:	10, 20, 25, 50, 100 μ l, < +0.25%, Brand or similar
Graduated cylinders	:	100, 200 and 500 ml
Pasteur pipettes	:	150 and 230 mm long
Sample vials	:	1.5 ml (Brown cat.no. 150900) with screw cap, Teflon lined (Brown cat.no. 150930)
Round bottomed flasks	:	250, 500 and 1000 ml, ground glass joint 24/29 3000 ml, ground glass joint 34/35
Centrifuge tube	:	15 ml, conical with ground glass plug 14/15, graded to 10 ml

4.20.2.5 Other equipment

Analytical balance, 0-160 g, precision \pm 0.02 mg
 Gloves, thin polyethylene, KEBO
 Gloves, solvent resistant of PE/EVOH/PE
 Membrane vacuum pumps with Teflon membrane (solvent resistant), 2.4 m³/h
 Metal cartridges (metal cylinders), for active carbon/ molecular sieve filter
 Micro balance, capacity 3000 mg, precision + 1 μ g
 Millipore, MilliQ plus, water purifier
 Pressure valve GA 2 (L'Air Liquide) with needle valve ALG 2B (L'Air Liquide)
 Porcelain dish
 TurboVap 500 pre-concentrator, Zymark
 Tissue paper Kimwipes, Kimberly-Clark
 Ultrasonic bath
 Heater mantles for round bottomed flasks for 500, 1000 and 3000 ml flasks
 Oven, 50–500°C

4.20.3 Chemicals and gases

Helium, 4.6	99.996%,	Hydro
Nitrogen Hydro Ultra, 5.0	99.999%,	Hydro

Active carbon, 1.5 mm diam., Merck no. 2514
 Chrompack Gas Clean moisture filter, no. 7971
 Chrompack Gas Clean oxygen/charcoal filter, no. 7972
 Molecular sieve, 0.5-2 mm diam., Merck no. 5707

Acetone, Merck no. 12
 Acetonitrile, Ratburn no. RH1016
 Diethylether, Ratburn no. RG2013
 2,2-Dimethoxypropane, Merck no. 802936
 Dimethylformamide, Rathburn no. RG2014
 Acetic acid, Merck no. 62
 Hexane, Merck no. 4371
 Chloroform, Merck no. 2445
 Methanol, Merck no. 6011

Sodium sulphate, Merck no. 6649

PAH-standards, see 6.1

RBS 25, lab detergent

Cyclohexane, Merck no. 2817

Toluene, Merck no. 8389

4.20.4 Cleaning of equipment and chemicals

4.20.4.1 Glass equipment

All glass equipment must be decontaminated before use. Leave the equipment in 2.5% RBS in water for 16 hours. Flush well with hot tap water followed by MilliQ water. Leave to dry on a clean surface.

4.20.4.2 Glass fibre filter

Put ca 50 filters (Gelman-Type A/E, 142 mm) on an Al-foil and heat to 450°C for 8 hours. After cooling to room temperature wrap each filter in Al-foil.

4.20.4.3 Extraction thimbles

Extract thimbles for 8 hours ("1 day") with cyclohexane in a 600 ml soxhlet extractor. Dry in a desiccator connected to a vacuum pump (capacity 2.4 m³/h, and 80 kPa (0.8 bar) at 100°C. Connect pump outlet to a cooler to condense solvent. Wrap dry thimbles in Al-foil.

4.20.4.4 Sampler

Dismantle the sampler. Wash glass, metal parts and gaskets with warm detergent (2.5% RBS 25 in water). Flush all parts except the gaskets, with warm water, distilled water and acetone. Flush the gaskets with warm water, distilled water, **not acetone**.

4.20.4.5 Sodium sulphate

Heat ca. 100 g sodium sulphate in a porcelain dish at 600°C for ca. 20 hours. Store in a 250 ml Pyrex bottle with tight screw cap. Label the bottle with date for cleaning. Max. storage time is 1 month.

4.20.4.6 PUF-plugs

Toluene

Clean new PUF-plugs with toluene (Merck no. 8389) in a 2000 ml soxhlet extractor. The extractor can take up to 8 plugs simultaneously. Use a 3000 ml round bottomed flask and fill toluene into the extractor until it empties the content into the round-bottomed flask. Add ca. 500 ml toluene and mount the lid and cooler. Turn on the heater and the **cooling water**. Extract the plugs for 24 hours.

Acetone, cyclohexane

Squeeze toluene out of the plugs (solvent resistant gloves!) and transfer the plugs to another 2000 ml soxhlet extractor. Acetone is added as prescribed for toluene and the plugs are extracted for 8 hours.

Finally, extract with cyclohexane (new extractor) for 8 hours.

Observe! Used plugs (which previously have passed through the whole cleaning procedure, toluene included) can be cleaned as follows:

- 1) Soxhlet extraction with acetone for 8 h
- 2) Soxhlet extraction with cyclohexane for 8 h

4.20.4.7 Drying

After final extraction squeeze the cyclohexane out of the plugs. Place the plugs in a desiccator. Put the desiccator in an oven at 60°C, and connect desiccator to a vacuum pump. Dry for 16 hrs and wrap the plugs in Al-foil individually. Store pairs of plugs and a filter in zip-shut plastic bags.

4.20.4.8 XAD-2

Fill XAD-2 in a thimble and put it in a soxhlet extractor. Extract for 8 h with each of the following solvents: Methanol, acetonitrile and diethyl ether. Leave the wet adsorbent on an Al-foil in a fume hood until it appears dry. Dry in an oven at 35°C overnight.

4.20.5 Gas cleaning

4.20.5.1 Gas bottle exchange

1. Gas bottles must be replaced when the pressure approach 20 bar. The bottle pressure should never be lower than 15 bar.
 2. Before exchanging GC-carrier gas bottles, set GC-oven temperature below 50°C.
 3. Bottle exchange should be performed rapidly. Collect the new bottle before disconnecting the old one.
 4. If only one spare bottle is in the storage room, order a new batch.
 5. Flush the bottle valve on the new bottle twice (ear protection) before connecting the pressure reduction valve.
 6. Connect pressure reduction valve firmly and open it.
 7. Check for leaks with leak detector (Ion Sciences: Gas Check B4 or Supelco: Snoop leak detector).
 8. Mount valve protection cap on the empty bottle and transport the bottle to the storage room.
- All bottles must be secured against falling over.

4.20.5.2 Special procedures

Helium GC carrier gas cleaning:

1. Chrompack Gas Clean Oxygen Filter (with charcoal) and Chrompack Gas Clean Moisture Filter are connected in series after the pressure reduction valve. Exchange the units after exchanging 5 bottles or once a year.
2. Two metal cartridges are mounted in series on the gas line before each GC inlet. The first is filled with active carbon, the second is filled with molecular sieves. Exchange adsorbents each 3 years and after irregularities (empty gas bottle).

Nitrogen used for final sample blow-down/pre-concentration is cleaned using a metal cartridge filled with active carbon. Exchange adsorbent when exchanging the gas bottle.

4.20.6 Treatment of adsorbents

Chrompack filters are discarded after use.

Re-activation of molecular sieves: Fill molecular sieves in a metal cartridge and activate at 300°C (3 h) in an oven, flushing the cartridge with 20 ml/min. pre-filtered helium.

Active carbon is discarded after use.

4.20.7 Analysis

Sampling, extraction, pre-concentration and weighing is described in chapters [3.14.4](#) - [3.14.7](#).

4.20.7.1 Adding internal standards

Depending of sample type the internal standard is added in an amount similar to the expected concentration level of the sample.

4.20.7.2 Clean-up

The extract is cleaned using liquid/liquid distribution between cyclohexane and dimethylformamide (DMF). Mix DMF and water in the ratio 9:1 (DMF:water), e.g. 180 ml DMF and 20 ml de-ionised water (MilliQ-plus).

1. The extract (4 ml) from 5.2 is transferred to a 15 ml centrifuge tube (graded to 10 ml). 3.2 ± 0.1 ml DMF/water (9:1) is added with a pipette. Plug the tube and shake.
2. Centrifuge for 5 min. at ca 2500 rpm. Transfer the cyclohexane phase, using a Pasteur pipette, to a new tube and add 1.2 ± 0.1 ml DMF/water (9:1). Shake well, centrifuge and add the DMF/water phase to the DMF/water from point 1. If no emulsion is formed after shaking the centrifuge step may be omitted. Discard the cyclohexane.
3. Add 5.2 ± 0.2 ml (10 ml pipette) water and 3.2 ± 0.1 ml cyclohexane to the DMF/water phase (totally 12.8 ml in the centrifuge tube). Shake well, centrifuge and remove (but keep) the cyclohexane phase. The DMF/water phase is extracted again with 1.0 ± 0.1 ml cyclohexane and the two cyclohexane phases are combined. Discard the DMF/water.
4. Add 2 ml water to "wash" the cyclohexane phase. Transfer the cyclohexane extract to a new glass and dry by adding 1/2 teaspoon of water free sodium sulphate. The extract is transferred to a new tube and pre-concentrated to 0.5 ml.

Often samples may be ready for GC/MS at this stage. Dirty samples may require an additional HPLC-clean-up step.

4.20.7.3 *Sample clean-up using HPLC*

Cleaned cyclohexane extracts, except low level samples from background areas, are cleaned using a silica-column (Lichrosorb SI-60-7, 250 x 4.6 mm). More polar compounds than unsubstituted PAHs will adsorb to the column, whereas the PAH-fraction elutes rapidly to be collected. The UV-detector is operated at 254 nm. The column is flushed with chloroform after each sample.

Between the pump and the eluent reservoirs a solvent switch makes it easy to change from one eluent to another. Cyclohexane, which is saturated with water, and chloroform are used as eluents. Water saturated cyclohexane is made by adding a few millilitres of water (MilliQ plus) to a bottle of cyclohexane. Sonicate the bottle for 30 min. Leave to separate overnight and decant the cyclohexane phase into another bottle the next day.

Start up:

1. Turn on the detector. Set sensitivity to 2.048 absorbance units.
2. Start the pump and set the flow to 1 ml/min. Check that there is no air in the tubes.

If there is, disconnect column, vent the air from the system and connect the column again.

3. Flush the column with cyclohexane for a few minutes. Turn on the recorder and check that the baseline is stable. The recorder settings are 10 mV and 30 cm/h.
4. Inject ca 1 ml (1000 µl syringe) of a naphthalene and coronene standard mix and mark the injection point on the recorder paper. Elute the compounds. Measure the distance from the injection point to the naphthalene peak start and from the injection point to the coronene peak end.

Use 90% of the distance to the naphthalene start and 125% of the distance to the coronene end, as measure for collecting the PAH fraction.

Sample clean-up:

1. Start the pump (1 ml/min) and the recorder and inject the sample with a clean syringe. Mark the injection point on the recorder paper.
- Collect the PAH-fraction in a 15 ml centrifuge tube after the measures described in the previous section.
3. Switch to the chloroform eluent reservoir and increase the flow to 2 ml/min.
4. After flushing most of the adsorbed compounds from the column (about 5 min), switch back to cyclohexane. When the baseline reaches the same level as before, the system is ready for the next injection.

5. After cleaning 10 samples, perform a new standard injection as described in 5.3.1.1.
6. Pre-concentrate the collected fraction, first using TurboVap and finally using a gentle nitrogen gas flow. Avoid evaporation of the sample to dryness.

4.20.7.4 Cleaning of the column

With time the columns separating performance will decrease and a cleaning is necessary. Make mixes of methanol/water 1:1 (50% vol. water) and methanol/water 19:1 (5% water) and hexane/acetic acid/dimethoxypropane 44:5:1 (88% vol. hexane, 10% vol. acetic acid, 2% vol. dimethoxypropane). Use the following solvents at a flow of 2 ml/min.:

1. Chloroform for ca 5 min.
2. Methanol for ca 5 min.
3. 1:1 Methanol/water for ca 30 min.
4. Methanol for ca 5 min.
5. Chloroform for ca 5 min.
6. Hexane/acetic acid/dimethoxypropane 44:5:1 for ca 20 min.
7. Chloroform for ca 5 min.
8. Methanol with 5% water for ca 5 min.
9. Chloroform for ca 5 min.
10. Cyclohexane saturated with water until the baseline is stable

4.20.8 Calibration and quantification

4.20.8.1 PAH-standards

The standards should have the highest possible purity and, if available, be certified.

Certified standards from Community Bureau of Reference (BCR):

	Purity (%)
Fluoranthene	99.49
Pyrene	99.75
Benzo[ghi]fluoranthene	99.4
Benz[a]anthracene	99.78
Chrysene	99.20
Triphenylene	99.77
Benzo[a]fluoranthene	99.5
Benzo[b]fluoranthene	99.5
Benzo[j]fluoranthene	99.5
Benzo[e]pyrene	99.0
Benzo[a]pyrene	99.3
Indeno[1,2,3-cd]pyrene	99.8
Dibenz[a,c]anthracene	99.5
Dibenz[a,h]anthracene	99.8
Benzo[ghi]perylene	99.0

Coronene	99.83
----------	-------

Standards from Tokyo Kasei Kogyo, Ltd., Japan:

	Purity (%)
Biphenyl	>99
Acenaphthene	>99
Phenanthrene	Zone Refined, 30 passes
Anthracene	Zone Refined, 70 passes
Fluorene	Zone Refined, 70 passes

Standard from Dr. Ehrensdorfer GmbH, Germany:

	Purity (%)
Dibenzothiophene	99.7

Standards from Promochem GmbH, Wesel, Germany:

	Purity (%)
Naphtalene	99.8
1-Methylnaphtalene	97
2-Methylnaphtalene	98
Acenaphthylene	99.8
3-Methylphenanthrene	99.8
2-Methylphenanthrene	99
2-Methylanthracene	>99
9-Methylphenanthrene	99.9
Benzo[b]fluorene	99.5
Cyclopenta[cd]pyrene	99
Anthanthrene	>99
Perylene	99.6
Dibenzo[a,e]pyrene	99.8
Dibenzo[a,i]pyrene	99.9
Dibenzo[a,h]pyrene	99.8

Certified standards from Chem Service, Inc., West Chester, USA:

	Purity (%)
1-Methylphenanthrene	99.5
Dibenzofuran	98
Benzo[a]fluorene	99
Retene	85
Benzo[k]fluoranthene	99.0

Labelled standards from C/D/N Isotopes Inc., Canada:

	Purity (%)
2-Methylnaphtalene-D ₁₀	99.3
Acenaphthene-D ₁₀	99.7
Anthracene-D ₁₀	99.3
Fluoranthene-D ₁₀	98.8
Pyrene-D ₁₀	99.9
Benz[a]anthracene-D ₁₀	99.1
Benzo[e]pyrene-D ₁₂	99.6
Benzo[ghi]perylene-D ₁₂	99,1

4.20.8.2 Main standard

The following compounds may be included in the main standard:

Naphtalene	Benzo[ghi]fluoranthene
2-Methylnaphtalene	Syklopenta[cd]pyrene
1-Methylnaphtalene	Benz[a]anthracene
Biphenyl	Chrysene
Acenaphthylene	Triphenylene
Acenaphthene	Benzo[b]fluoranthene
Dibenzofuran	Benzo[j]fluoranthene
Fluorene	Benzo[k]fluoranthene
Dibenzothiophene	Benzo[a]fluoranthene
Phenanthrene	Benzo[e]pyrene
Anthracene	Benzo[a]pyrene
3-Methylphenanthrene	Perylene
2-Methylphenanthrene	Indeno[1,2,3-cd]pyrene
2-Methylanthracene	Dibenz[a,c]anthracene
9-Methylphenanthrene	Dibenz[a,h]anthracene
1-Methylphenanthrene	Benzo[ghi]perylene
Fluoranthene	Anthranthene
Pyrene	Coronene
Benzo[a]fluoren	Dibenzo[ae]pyrene
Retene	Dibenzo[ai]pyrene
Benzo[b]fluoren	Dibenzo[ah]pyrene

Perform the weighing using the micro balance. Use gloves and a dust mask.

Spatulas and other equipment should be rinsed with toluene before use. When all compounds are weighed, transfer them to a 25 ml volumetric flask using a Pasteur pipette and toluene. Fill the flask to the mark and sonicate until all PAH is dissolved. Compute the exact concentration for each compound (ng/μl). The individual concentration should be in the range 15±10 ng/μl. This corresponds to 300±100 μg of each single compound. Transfer mix to well labelled vial with Teflon lined screw cap. Weigh the vial and store it in a freezer.

4.20.8.3 Internal standards

The internal standard includes the following compounds: 2-methylnaphtalene-D₁₀ (ISTD I), acenaphthene-D₁₀ (ISTD II), anthracene-D₁₀ (ISTD III), pyrene-D₁₀

(ISTD IV), benz[a]anthracene-D₁₂ (ISTD V), benzo[e]pyrene-D₁₂ (ISTD VI), benzo[ghi]perylene-D₁₂ (ISTD VII).

Ca. 1 mg of ISTD I, II, III, IV and ca 0.5 mg of ISTD V, VI, VII are weighed as described under 6.1.1 and transferred to a 25 ml volumetric flask filled to the mark with cyclohexane. The concentration range is ca 20-40 ng/μl. Transfer mix to a well-labelled vial with Teflon lined screw cap. Weigh the vial and store it in a freezer.

Transfer ca. 1 ml to a sample vial. Label the vial and use as working standard. Weighing is not necessary. Store in a refrigerator.

4.20.8.4 Recovery standard

As recovery standard fluoranthene-D₁₀ may be used. Weigh in ca 1 mg, transfer to a 25 ml volumetric flask and fill to the mark with cyclohexane as described in 6.1.1. Transfer mix to well labelled vial with Teflon lined screw cap. Weigh the vial and store it in a freezer.

Transfer ca 1 ml to a sample vial. Mark the vial and use as working standard. Weighing is not necessary. Store in a refrigerator.

4.20.8.5 Quantification standard

Remove the flasks with main standard, internal standard and recovery standard from the freezer and leave to melt at room temperature. Use aluminium foil to protect the flasks against sunlight. Remove the foil and sonicate flasks for 5 minutes. Check that all PAH is dissolved. If crystals are visible, repeat sonication. Check the flasks for weight loss and compensate an eventual loss with solvent. 2 ml main standard is transferred to a 50 ml volumetric flask using a 2 ml pipette. To the same flask further 1 ml internal standard and 2 ml recovery standard are transferred. Fill the flask to the mark with cyclohexane. Transfer mix a well labelled vial with Teflon lined screw cap. Weigh the vial and store it in a freezer.

Transfer ca. 1 ml to a sample vial. Label the vial and use as working standard. Weighing is not necessary. Store in a refrigerator.

4.20.8.6 Control standard

This standard is used to check the GC/MS quantification performance (chapter 6.2.4). The standard may contain the following compounds:

- Biphenyl
- Phenanthrene
- Fluoranthene
- Benzo[a]anthracene
- Benzo[e]pyrene
- Benzo[ghi]perylene

First a mother standard is made as described under **6.1.1**. 300 ± 100 μg of each compound is weighed and dissolved in cyclohexane in a 10 ml volumetric flask. Label the flask, weigh and store in a freezer.

Working solution is made as described under **6.1.2**. 1 ml. The mother standard is diluted to 50 ml with cyclohexane in a 50 ml volumetric flask. Store the flask in a freezer.

Transfer ca. 1 ml to a 2 ml sample vial. Label the vial and use as working standard. Weighing is not necessary. Store in a refrigerator.

4.20.8.7 Retention standard, HPLC

This standard is used to check retention times before HPLC clean-up.

Ca. 5 mg naphthalene and ca. 10 mg coronene is dissolved in 100 ml cyclohexane. The concentrations are ca. 50 μg naphthalene and ca. 100 μg coronene pr. ml. Store in a refrigerator.

4.20.9 Separation and quantification

The cleaned sample extracts are analysed using gas chromatography combined with mass spectrometry (GC/MS). The compounds are identified according to their retention time and molecular weight and quantified using internal standards.

4.20.9.1 GC separation

GC conditions:

- Column : CP-Sil 8CB, 25 m x 0.25 mm x 0.12 μm film thickness or similar.
- Injector temperature : 300°C
- Temperature program: 50-100°C with 20°C/min., 100-300°C with 10°C/min., 300°C for 5-10 min.
- Carrier, helium : 85 kPa
- Split gasflow : 40 \pm 10 ml/min.
- Sample volume : 1 μl splitless, (Autosampler or "hot-needle" injection)

Autosampler conditions:

- Solvent A : toluene
- Solvent B : cyclohexane
- Sample wash : 0
- Sample pumps : 6
- Sample volume : 1 μl
- Solvent A, washes : 6
- Solvent B, washes : 6

Solvent A and B for syringe cleaning must be exchanged each day.

4.20.9.2 Mass spectrometry (MS)

Electron impact ionisation (EI) is used. Inject the quantification standard before each sample series and after each 10 samples.

MS conditions for EI (MSD 5970 and MSD 5973):

- GC/MS-interface : 290°C
- Electron energy : 70 eV
- Calibration compound : Perfluorotributylamine (PFTBA)

Automatic tuning (“Autotune”), or manual optimisation of mass scale and transmission of the mass filter (quadrupole) with PFTBA using mass fragments m/z 69.0, 219.0 and 502.0. Mass resolution, signal width at half height: 0.55 ± 0.03 . Calibration of mass scale at ± 0.05 amu.

The following SIM-program may be used for quantification:

SIM-function	Compound group	Mass	
1	Naphtalene	128.1	
	2-Methylnaphtalene	142.1	
	1-Methylnaphtalene	142.1	
	d ₁₀ z-Methylnaphtalene	152.1	
	Biphenyl	154.1	
2	Acenaphthylene	152.1	
	Acenaphthene	154.1	
	d ₁₀ Acenaphthene	164.1	
	Dibenzofuran	168.1	
	Fluorene	166.1	
3	Dibenzothiophene	184.1	
	Phenanthrene	178.1	
	Anthracene	178.1	
	d ₁₀ Anthracene	188.1	
	3-Metylphenanthrene	192.1	
	2-Methylphenanthrene	192.1	
	2-Methylanthracene	192.1	
	9-Methylphenanthrene	192.1	
1-Methylphenanthrene	192.1		
4	Fluoranthene	202.1	
	d ₁₀ Fluoranthene	212.1	
	Pyrene	202.1	
	d ₁₀ Pyrene	212.1	
	Benzo[a]fluorene	216.1	
	Retene	234.1	
	Benzo[b]fluorene	216.1	
	Benzo[ghi]fluoranthene	226.1	
5	Cyclopenta[cd]pyrene	226.1	
	Benz[a]anthracene	228.1	
	d ₁₂ Benz[a]anthracene	240.1	
	Chrysene/triphenylene	228.1	
	6	Benzo[b/j/k]fluoranthenes	252.1
		Benzo[a]fluoranthene	252.1
Benzo[e]pyrene		252.1	
d ₁₀ Benzo[e]pyrene		264.1	
Benzo[a]pyrene		252.1	

SIM-function	Compound group	Mass
7	Perylene	252.1
	Inden[1,2,3-cd]pyrene	276.1
	Dibenz[a,c/a,h]anthracenes	278.1
	Benzo[ghi]perylene	276.1
	d ₁₀ Benzo[ghi]perylene	288.1
	Anthanthrene	276.1
	Coronene	300.1
	Dibenzo[a,e]pyrene	302.1
	Dibenzo[a,i]pyrene	302.1
	Dibenzo[a,h]pyrene	302.1

If compounds occur at concentrations which saturate the detector these compounds may be quantified using the signal from the ¹³C-isotope in the compound, detected at a mass one amu higher than the number indicated in the table.

4.20.9.3 Quantification

1. Relative response factors, RRF_i , are computed for the single compounds relative to the internal standard (ISTD) after analysing the quantification standard with known concentrations.

$$RRF_i = \frac{Amt_{ISTD} \cdot Area_i}{Amt_i \cdot Area_{ISTD}}$$

- RRF_i : Relative response factor of compound i
 Amt_{ISTD} : Amount of internal standard injected
 Amt_i : Amount of compound i injected
 $Area_i$: Peak area of compound i
 $Area_{ISTD}$: Peak area of internal standard

2. Quantification of samples is based on relative response factor, added amount internal standard and the peak area of each compound i .

$$Amt_{i,j} = \frac{Amt_{ISTD} \cdot Area_i}{RRF_i \cdot Area_{ISTD}}$$

- $Amt_{i,j}$: Amount of compound i in the sample
 Amt_{ISTD} : Amount of internal standard added
 $Area_i$: Peak area of compound i
 RRF_i : Relative response factor for compound i
 $Area_{ISTD}$: Peak area of internal standard

Check the chromatogram for eventual interference and correct retention times before quantification.

3. Recovery of internal standard (added before sample clean-up) is computed relative to amount of recovery standard added before the quantification.

Relative response factors based on the recovery standard (RRF_g) is calculated for each ISTD-compound from the quantification standard analysis.

$$RRF_g = \frac{Amt_{GSTD} \cdot Area_{ISTD}}{Amt_{ISTD} \cdot Area_{GSTD}}$$

$$Rec.(%)_{ISTD} = \frac{Amt_{GSTD} \cdot Area_{ISTD} \cdot 100}{RRF_g \cdot Amt_{ISTD} \cdot Area_{GSTD}}$$

Amt_{ISTD}	:	Amount internal standard added before extraction
Amt_{GSTD}	:	Amount of recovery standard added before quantification
$Area_{ISTD}$:	Peak area of internal standard
$Area_{GSTD}$:	Peak area of recovery standard

4.20.9.4 GC/MS-analysis

1. Before each sample series the quantification standard is injected twice. The first injection is used to deactivate the injector and is not used for quantification.
2. Inject the quantification standard not later than each 10 samples.
3. The last injection should be a quantification standard.

4.20.9.5 Detection limit

The detection limit is defined as 3 times the noise level (compound signal/noise = 3:1) as shown in the following figure.

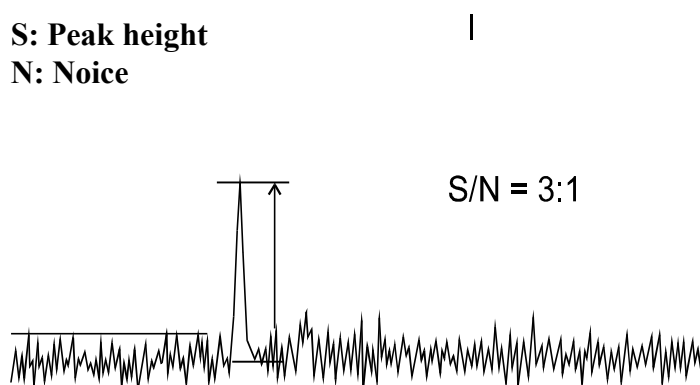

For outdoor air the detection limit is normally reported in the unit pg/m^3 . The detection limit varies according to the concentration level in the sample, the sample volume, the purity of the sample extract, sample loss during clean-up and the pre-concentration factor.

4.20.10 Quality assurance

4.20.10.1 Reception and storage of samples

Incoming samples must be registered in a sample journal with date, a sample number and an analysis form which follows the sample during the whole analysis.

A cleaned sample extract ready for GC/MS may be stored up to 6 months in a freezer before analysis.

4.20.10.2 Standard mixtures

PAHs dissolved in cyclohexane and stored in a freezer (dark) are stable for years. The main standard, quantification standard, internal standard, control standard and recovery standard must be stored in a freezer ($\leq 18^{\circ}\text{C}$). Control of weight and corrections for weight loss must be recorded. Max. storage time is 5 years.

The working solutions are stored in a refrigerator ($4-6^{\circ}\text{C}$) and weight loss control is not necessary. Max. storage time is 6 months.

All new standards must be checked against the old standard and concentration deviations should be within $\pm 10\%$.

4.20.10.3 Control standard

To check the GC/MS quantification a control standard must be analysed. The standard covers the whole volatility range of the PAHs to be quantified.

The standard must be analysed after every 20th sample or every 14th day when less than 20 samples are analysed. For long periods without any activity (months), the standard must be analysed once a month.

Plots showing the single results for each compound and an average of the last 10 analyses must be available.

4.20.10.4 Recovery of internal standard

Before GC/MS-analysis a recovery standard is added to the sample in an amount according to the amount of internal standard added.

The recovery of the internal standards should be within the following limits:

ISTD	II	>10 to 100%
ISTD	III, IV	>20 to 100%
ISTD	V, IV, VII:	>30 to 120%

Since the results for bicyclic PAHs is uncertain and the interest for these compounds is low, no limit is given for ISTD I.

If recovery is outside limits a note about this must be given in the analysis report. Low recovery is caused by losses during clean-up and pre-concentration. The result will be less reliable than with normal recovery.

Too high recovery may be caused by interference on the ISTD-signal. In such cases the quantification should be based on another ISTD with normal recovery.

4.20.10.5 Blanks

Blank tests must be performed on clean filters and PUF plugs using the complete method. 2 unexposed plugs and 1 unexposed filter are extracted and analysed as if it was a normal sample. This must be done after each 20th sample.

4.20.10.6 Control of results

The following criteria must be fulfilled for a satisfactory identification and quantification:

- Clean, undisturbed mass fragmentograms
- Adequate GC separation
- Correct retention times. The retention time should be within ± 3 sec. relative to the retention time of the compound in the quantification standard
- Signal/noise ratio $>3:1$
- Blank values should be 10 times lower than the lowest expected level in the samples.

4.21 Chemical speciation of particles

4.21.1 Introduction

The inorganic fraction of the aerosol mass consists mainly of sulphate, ammonium, and nitrate containing particles. Other ions contribute to a less extent to the inorganic fraction. It is recommended to measure all soluble base cations, sodium, potassium, calcium, and magnesium, as well as chloride. Participants applying ion chromatography for analysis of the EMEP filterpack aerosol filter for sulphate, nitrate and ammonium (see chapter 3.2) should be able to obtain the base cations and chloride concentrations on a daily basis.

The recommended measurement program also includes EC/OC measurements. The carbon fraction typically constitutes ~ 30 per cent of the mass and contains elemental carbon (EC) and a huge number of different organic carbon (OC) compounds. It is recommended to determine the amounts of EC and OC in at least one sample every week from each station in the start phase. A (partial) speciation of the organic fraction is also of great interest, but this will mainly be a research activity applying advanced laboratory equipment and rather complicated chemical procedures and not applicable on all EMEP sites

4.21.2 Extraction

For extraction of water-soluble constituents from the PM₁₀ filters, it is recommended to use a punch to remove an accurately defined part of the exposed area of the sample filter. The diameter should be chosen to allow for a similar sub-sample to be taken for the determination of elemental and organic carbon (see below). A suitable size would be a circular punch, of diameter 3-5 cm. The extraction volume should be at least 10 ml. The filters are put in tubes and deionised water is added, the tubes should be kept in ultrasonic bath for at least 30 minutes to obtain a complete extraction. When quartz or other fibre filters are used, be careful to avoid breaking up the filter by unnecessary stirring, because loose fibres in the solution do not go well with the ion chromatograph! Filtration of the extract may be necessary.

If heavy metals are to be determined by e.g. ICP-MS it is necessary to use acidic extraction agent, see chapter [3.11.5](#).

4.21.3 Determination of the inorganic components

Chemical speciation should primarily include determination of sulphate, nitrate, ammonium and other water-soluble ions in filter samples. The latter will include sea-salt, which contributes significantly to the PM₁₀ in coastal regions in Western Europe. The concentrations of aerosol sulphate, nitrate and ammonium ions are usually determined in connection with the normal EMEP measurement programme, and the determination of these water-soluble ions by ion chromatography of filter extracts can be used to give data also for sodium, potassium, magnesium, calcium and chloride, particularly if the recommendations for sampling given in the chapter 4.1-4.6 are followed (see also Tørseth et al., 1999).

4.21.4 Determination of heavy metals

Heavy metals do not usually give a significant contribution to the particulate mass, and it is not important to measure these components just to obtain a mass closure. But aerosols play an important role as a carrier of heavy metals. Sampling methods of heavy metals in particles are found in chapter 3.11 and the analytical methods are found in 4.17. In addition, heavy metals may be determined using PIXE and INAA described under mineral dust, 4.21.7.

4.21.5 EC/OC determination

The quantification of elementary carbon and organic compounds (EC/OC) in aerosol particles is of considerable interest. The ratio between EC and OC is often used as a valuable tool for the elucidation of the origin of the air masses investigated. Elementary carbon is present in the form of chain aggregates of small soot globules, and is responsible for the light absorption of the material collected on filters. Unfortunately this light absorption depends on the size distribution of the soot particles and on the association of the soot particles with other substances in the aerosol particles and on sample filters. Optical methods to determine EC are therefore only semi-quantitative, and calibration factors may vary from one situation to another, see e.g. (Liousse and Jennings, 1993).

The recommended method to determine elementary carbon is therefore by successive volatilization and oxidation of the sample, and to determine the evolved CO₂, either directly or after conversion to CH₄ by a flame ionization detector (FID). This procedure also gives the total carbon content, and a quantification of the amount of organic materials through the organic carbon content of the aerosol particles. The method is not free of artefacts, particularly the charring or incomplete removal of organic compounds may lead to the overestimation of EC. To compensate for this, optical detection of a darkening of the filter during the last stage of the OC volatilization is recommended (Chow et al. 1993; Huntzicker et al. 1982). This method is now part of the USEPA programme, and the equipment described by Birch and Cary (Birch and Cary, 1996) is commercially available (Sunset Laboratory Inc., USA). CCC has opportunity to analyse samples collected on quartz fibre filters and the equipment is also available in other laboratories in Europe. A factor of 1.4 is tentatively recommended to convert the measured OC content to total organic particulate mass.

Chemical analyses for further speciation of the organic component in aerosol particle samples are much more demanding, although some advances have been made in determining the water-soluble organic aerosol mass, and specific fractions of this mass. Quantification of selected chemical compounds by gas chromatography and other methods is also possible, but the number of individual compounds is very large, and chemical analyses should therefore be directed to determination of "signature" compounds, which are indicative of certain groups or specific emission sources (e.g. wood combustion).

4.21.6 *Chemical characterization of the OC fraction*

High performance liquid chromatography (HPLC) combined with mass spectrometry (MS) have reached a state where identification of unknown compounds has become possible at quantities about 1 ng. From the accurate mass determined, the elemental composition of an unknown can be calculated. Combination of retention time data obtained during a HPLC run, the corresponding UV spectra, and the isotope pattern in the mass spectrum, makes possible calculations of possible elemental compositions. Commercially available chemistry databases should allow the identification of unknown compounds present in the aerosol samples. Based on the solubility, particulate matter can be defined as water soluble organic carbon fraction (WSOC) and water insoluble organic carbon fraction (WINSOC). According to Zappoli and co-workers (Zappoli et al. 1999), the WINSOC fraction can be further separated into solvent extractable polar organic compounds (SEPOC); solvent extractable non-polar organic compounds (SENOC) and non extractable organic compounds (NEC).

Derivatisation with alkylchloroformates is helpful for trace analytical purposes. Alkylchloroformates have unique properties which allows to derivatise nearly all polar compound classes simultaneously; phenols, organic acids, hydroxylated acids, amines etc. Derivatisation with alkylchloroformates will be used in order to obtain a complementary sample preparation to the approaches below.

For polar organic compounds, the following sample preparation and analytical methods can be used:

- Molecular size distribution of the organic content of particles will be obtained by LC/MS. The work may be supported by high resolution gel permeation chromatography.
- A LC/MS (TOF) method for the identification of polar to very polar organic compounds in particles of high carbonaceous content. The method will be an important tool to characterize sources.
- Comparison of the extract content of different solvent extraction methods in order to optimise yields and efficiency.
- Comparison of the developed method with (or without) conventional derivatisation and GC-MS analysis (high resolution MS) to compare information and for quality assurance.
- The development of a general derivatisation procedure based on alkylformates for polar to very polar organic compounds in particle extracts.

In order to distinguish between the water-soluble OC and water insoluble OC compounds the following techniques can be used:

- 1.) A gentle filter washing with water giving a water-soluble fraction and water insoluble fraction.
- 2.) The water insoluble fraction remaining on the filter is dried and divided into two parts. One part is analysed for cellulose. The other part is extracted with sodium hydroxide (NaOH) in two increasing concentration steps in order to obtain the "humic acids" and the "humins" fractions according to the procedure in Havers et al. (Havers et al. 1998). The quantification of the humic acids

and humic fractions will be performed via micro-combustion analysis. Combustion method is described in Puxbaum et al. (Puxbaum et al. 2000).

- 3.) The water-soluble fraction will be separated into three fractions by two-step solid phase extraction: weakly polar compounds (fatty acids, fatty aldehydes, fatty alcohols, esters), strong polar compounds (dicarboxylic acids and other multifunctional compounds), and macromolecular water soluble compounds ("fulvic acids"). Weakly and strong polar compounds can be determined as described by Limbeck and Puxbaum (Limbeck and Puxbaum, 1999). The macromolecular fraction is determined by the micro-combustion technique as mentioned above.

4.21.7 Analysis of mineral dust

Mineral dust may often contribute significantly to the particle mass and to generate a total mass closure it is important to determine this fraction. Monitoring of air pollution has mainly been focused on anthropogenic sources, mineral dust has therefore traditionally not been measured because of its more natural origin, even though atmospheric dust can be an indirect result of land use and human activities. Mineral dust is a mirror of the earth crust and consists mainly of silicates and oxides of silicon, aluminium and iron. The relative importance of mineral dust in particulate matter depends on location, season and particle size, it is mainly concentrated in the coarse fraction. There can be large local variations depending on the source, e.g. Sahara dust can give a large contribution of the PM₁₀ concentration in southern Europe.

Mineral dust has in general low solubility and is therefore difficult to analyze using instruments like ICP-MS, ICP-AES, AAS etc. To dissolve e.g. silicon it is usually necessary to use strong solvents as hydrofluoric acid. This solvent is however not very practical for most instruments and needs special precautions. As a consequence XRF, INAA and PIXE are the most commonly used techniques for analyzing mineral dust, Table 4.21.1. These techniques have a major advantage that the sample can be analyzed directly from the filter avoiding uncertainties of whether everything is dissolved when using solvent techniques. An additional advantage using PIXE, INAA or XRF is the multielement analysis thereby the possibility to get information of the concentrations of heavy metals in particulate matter as well.

Table 4.21.1: Analytical methods used for analyzing mineral dust.

Analytical method	Disadvantages	Advantages
Proton induced X-ray emission (PIXE)	Demanding	Sensitive, multielement analysis
Neutron activation analysis (INAA)	Demanding, silicon cannot be analysed, time consuming	Sensitive, multielement analysis
X-ray fluorescence (XRF)	High detection limit for silicon, absorption	Multielement analysis
X-ray diffraction (XRD)	Insensitive	Composition of species
Microscopy	Difficult to quantify the species	Characterization of particles

Proton induced X-ray emission (PIXE) and neutron activation analysis (INAA) are excellent instruments for dust analysis, but they are demanding methods

needing a proton and neutron accelerator respectively, and for most laboratories X-ray-fluorescence (XRF) is easier accessible, XRF is however less sensitive. The theory behind the techniques are found in numerous textbooks (see e.g. a review by Török et al, 1996) and will not be described here, neither will a detailed analytical description, since it is dependent on the instrument, and the user manual from the manufacture should be used to set up a standard operational procedure.

One major problem analysing the content of mineral dust is the low sensitivity for silicon in most analytical techniques. PIXE is the only method that has proven to be suitable for this element. However, it is possible to analyse e.g. aluminium or iron to estimate the amount of crustal mass in the sample using the known composition of the earth's crust (Mason, 1966); although one should bear in mind that the chemical composition of the mineral dust is not necessarily consistent because of influence from sources where some of the crustal elements are enriched (Rahn, 1976 and 1999).

X-ray fluorescence (XRF) analysis can be used for all elements passed the first row in the periodic table and the detection limit is dependent on element ranging from 20 to 200 ng/cm² for 44 of 49 elements (Willeke and Baron, 1993). Two different types of instrumentation can be used, wavelength dispersive (WD-XRF) and energy dispersive (ED-XRF). ED-XRF provides simultaneous determination of multiple elements, whereas WD-XRF usually determines one element at a time. The latter technique has somewhat lower detection limits for elements with low atomic number and it has better spectral resolution compared with ED-XRF where interference and line overlap may be a problem (Claes et al, 1998). Absorption of primary and emitted X-rays can be a problem, but if the deposition is thin, X-ray is not absorbed in the matrix and conversion into concentrations is simplified considerably. The filters may also absorb X-rays; membrane filters where the aerosols are collected on the surface are much better compared to filters where the aerosol is collected in the material. Filters of low mass are also preferable to minimize the background scattering. Teflon membrane filters are frequently used. Glass fibre filter should not be used due to higher absorption and since the content of silicon then can't be determined. Nucleopore filters may also be used (Willeke and Baron, 1993; Claes et al., 1998). The particles should preferably be quite small and the deposition should be homogenous. This is even more critical for the PIXE technique where only a very small part of the filter is analyzed. PIXE differ from XRF in excitation source for X-ray fluorescence, using high-energy protons. Nucleopore filters should be used because fluoride in Teflon filter causes problems for PIXE analysis. This technique is described in more detail by e.g. Maenhaut (1987). INAA is similar to PIXE regarding limits of detection and it is also suitable to determine a large number of elements in the samples (Willeke and Baron, 1993). The advantage of INAA is the almost absence of matrix effects, self-absorption and interferences. It can be used to analyze thick and inhomogeneous samples; the disadvantage is of course the need for a nuclear reactor and special expertise.

X-ray diffraction (XRD) can sometimes be used depending on the concentration level. The great advantage of XRD is that it gives the composition of the minerals, which is not possible with the above mentioned element analysis. The most important use of XRD has been for silica (Lodge, 1989). The problem with this

technique is the low sensitivity and for background sites the concentration levels are usually too low. To improve the low peak intensity/background ratio the dust can be deposited on Ag-filters or silicon (5 1 0) plates (Queralt et al., 2001).

Microscopy can also be a powerful tool to identify the different minerals in particles; though, in practice not easy to use for quantification.

4.21.8 References

- Birch, M.E. and Cary, R.A. (1996) Elemental carbon-based method for monitoring occupational exposures to particulate diesel exhaust. *Aerosol Sci. Technol.*, 25, 221-241.
- CEN (1998) Air quality. Determination of the PM₁₀ fraction of suspended particulate matter. Reference method and field test procedure to demonstrate reference equivalence of measurement methods. Brussels (EN 12341).
- Chow, J.C., Watson, J.G., Pritchett, L.C., Pierson, W.R., Frazier, C.A. and Urcell, R.G. (1993) The DRI thermal/optical reflectance carbon analysis system: description, evaluation and application in U.S. air quality studies. *Atmos. Environ.*, 27A, 1185-1201.
- Claes, M., Gysels, K., van Grieken, R. and Harrison, R.M. (1998) Inorganic composition of atmospheric aerosols. In: *Atmospheric particles*. Ed. by R.M. Harrison and R. van Grieken. Chichester, Wiley. p. 95-146.
- Havers, N., Burba, P., Lambert, J. and Klockow, D. (1998) Spectroscopic characterisation of humic-like substances in airborne particulate matter. *J. Atmos. Chem.*, 29, 45-54.
- Huntzicker, J.J., Johnson, R. Lo., Shah, J.J. and Cary, R.A. (1982) Analysis of organic and elemental carbon in ambient aerosol by a thermal-optical method. In: *Particulate carbon. Atmospheric life cycle*. Ed. by G.T. Wolff and R.L. Klimisch. New York, Plenum. p. 79-88.
- Limbeck, A. and Puxbaum, H. (1999) Organic Acids in continental background aerosols. *Atmos. Environ.*, 33, 1847-1852.
- Liousse, C. and Jennings, S.G. (1993) Optical and thermal measurements of black carbon aerosol in different environments. *Atmos. Environ.*, 27A, 1203-1211.
- Lodge Jr., J.P. (1989) *Methods of air sampling and analysis*. 3rd ed. Chelsea, Mi: Lewis.
- Maenhaut, W. (1987) Particle induced X-ray emission spectrometry: An accurate technique in the analysis of biological, environmental and geological samples. *Anal. Chem. Acta*, 195, 125-140.
- Mason, B. (1966) *Principles of geochemistry*. 3rd ed. New York, Wiley.

- Puxbaum, H., Rendl, J., Allabashi, R., Otter, L. and Scholes, M.C. (2000) Mass balance of atmospheric aerosol in a South-African subtropical savanna (Nylsvley, May 1997). *J. Geophys. Res.*, *105*, 20697-20706.
- Queralt, I., Sanfeliu, T., Gomez, E., Alvarez, C. (2001) X-ray diffraction analysis of atmospheric dust using low-background support. *J. Aerosol Sci.*, *32*, 453-459.
- Rahn, K.A. (1976) Silicon and aluminium in atmospheric aerosols: Crust-air fractionation? *Atmos. Environ.*, *10*, 597-601.
- Rahn, K.A. (1999) A graphical technique for determining major components in a mixed aerosol I. Descriptive aspects? *Atmos. Environ.*, *10*, 597-601
- Tørseth, K., Hanssen, J.E. and Semb, A. (1999) Temporal and spatial variations of airborne Mg, Cl, Na, Ca and K in rural areas of Norway. *Sci. Total Environ.*, *234*, 1-3, 75-85.
- Török, S.B., Lábár, J., Imjuk, J. and van Grieken, R.E. (1996) X-ray spectrometry. *Analytical Chem.*, *68*, 467R-485R.
- Willeke, K. and Baron, P.A. (1993) Aerosol measurement. Principles, techniques and applications. New York, Van Nostrand Reinhold.
- Zappoli, S., Andracchio, A., Fuzzi, S., Facchini, M.C., Gelecsér, A., Kiss, G., Krivacsy, Z., Molnar, A., Meszaros, E., Hansson, H.-C., Rosman, K. and Zebühr, Y. (1999) Inorganic, organic and macromolecular components of fine aerosol in different areas of Europe in relation to their water solubility. *Atmos. Environ.*, *33*, 273-2743.

5. Quality assurance

General guidelines considering the quality assurance work within EMEP were given in the EMEP Quality Assurance Plan (EMEP/CCC-Report 1/88). While there have been considerable improvements in the quality assurance work within EMEP over the last years, there is still need for improvements. The EMEP/WMO workshop in Passau on accuracy of measurements (EMEP/CCC Report 2/94) gave a series of recommendations aiming at an improved quality assurance. These recommendations have been accepted by the EMEP Steering Body in 1994, and will form a basis for the QA programme within EMEP. Important steps in this programme are:

- Appointment of an EMEP QA Manager at the CCC, and a National QA manager in each of the participating countries. These will be responsible for implementing harmonized quality assurance systems within the countries, including documentation of standards and reference materials.
- Development of standardized operating procedures based on the recommendations in this Manual.
- Co-location experiments and instrument comparisons in the various countries to document precision and quantify internal network differences.
- Continuation of efforts towards site characterization.

It was also agreed to continue exchange of views and information with the WMO, since the WMO GAW network share a number of the stations and measured parameters. Since then further discussions have taken place between EMEP and WMO/GAW and there is a strong desire to harmonize and coordinate the efforts in order not to duplicate activities and efforts.

The implementation of the recommendations above will be a gradual process, starting with the establishment of responsible National QA managers.

Guidelines for the QA work are given in the following sections.

5.1 Job description for EMEP's National Quality Assurance Manager

The overall goal of the quality assurance activities is to provide data which meet the EMEP Data Quality Objectives (Section 5.2).

The EMEP quality management and quality system which will build further on the Quality Assurance Plan for EMEP and the Manual for Sampling and Chemical Analysis, will in general follow the guidelines in the ISO 9004 standards, and the guidance given in EN 45001, ISO/IEC Guide 25, and the WELAC Guidance Document No. WGD 2 or the updated version EAL-G4.

The quality assurance activities will therefore follow normal accepted standards and recommendations for good measurement practice. The quality system will, when fully implemented, ensure the targeted data quality.

The concept of quality system implementation requires that NQAM have the authority and full support at national level.

NQAM are then responsible for implementation of the EMEP quality system within his/her own country and for its supervision.

The responsibilities include among other duties:

- Preparation of standard operating procedures (SOP) based on EMEP's recommended methods, when the recommended methods are in use,
- to develop SOPs for other methods in use,
- to document that these other methods are at least as precise and accurate as EMEP's recommended methods, and have a corresponding low detection limit,
- to co-operate with the CCC in comparison experiments both with respect to comparison with reference equipment in order to quantify differences between the measurement systems, and with respect to two identical national measurement systems in order to quantify precision,
- the timely reporting of measurement data to the CCC,
- the reporting of quality assurance data, with the DQO, to the CCC which will compile this data in annual reports,

and in particular

- to perform audits in co-operation with the CCC,
- to document sites and site surroundings, measurements, and standards and reference materials used,
- the quality control including data checking and validation.

The NQAM shall have direct access to the highest level of management at which decisions are taken on measurement policy and on resources, and will work in close co-operation with the EMEP Quality Assurance Manager.

5.2 EMEP Data Quality Objectives (DQO)

5.2.1 DQO for the acidifying and eutrophyng compounds

- 10% accuracy or better for oxidised sulphur and oxidised nitrogen in single analysis in the laboratory,
- 15 % accuracy or better for other components in the laboratory,
- 0.1 units for pH,
- 15–25% uncertainty for the combined sampling and chemical analysis (components to be specified later),
- 90 % data completeness of the daily values.
- The targets, with respect to accuracy in the laboratory, for the very lowest concentrations of the main components in precipitation follow the WMO GAW (1992) recommendations for regional stations:

	Accuracy	
SO ₄ ²⁻	0.032 mg S/l	(1 µmol/l)
NO ₃ ⁻	0.014 mg N/l	(1 µmol/l)
NH ₄ ⁺	0.028 mg N/l	(2 µmol/l)
Cl ⁻	0.107 mg Cl/l	(3 µmol/l)
Ca ²⁺	0.012 mg Ca/l	(0.3 µmol/l)
K ⁺	0.012 mg K/l	(0.3 µmol/l)
Mg ²⁺	0.007 mg Mg/l	(0.3 µmol/l)
Na ⁺	0.007 mg Na/l	(0.3 µmol/l)

The targets for the wet analysis of components extracted from air filters are the same as for precipitation. For SO₂ the limit above for sulphate is valid for the medium volume method with impregnated filter. For NO₂ determined as NO₂⁻ in solution the accuracy for the lowest concentrations is 0.01 mg N/l.

The aim for data completeness is valid for the current definition used by the CCC. This definition will, however, be harmonised with the WMO GAW definition and modified.

5.2.2 DQO for heavy metals

- 90% completeness
- 30% accuracy in annual average
- Accuracy in laboratory (c= concentration):

Pb: 15% if $c > 1 \mu\text{g Pb/l}$
 25% if $c < 1 \mu\text{g Pb/l}$

Cd: 15% if $c > 0.5 \mu\text{g Cd/l}$
 25% if $c < 0.5 \mu\text{g Cd/l}$

Cr: 15% if $c > 1 \mu\text{g Cr/l}$
 25% if $c < 1 \mu\text{g Cr/l}$

Ni: 15% if $c > 1 \mu\text{g Ni/l}$
 25% if $c < 1 \mu\text{g Ni/l}$

Cu: 15% if $c > 2 \mu\text{g Cu/l}$
 25% if $c < 2 \mu\text{g Cu/l}$

Zn: 15% if $c > 10 \mu\text{g Zn/l}$
 25% if $c < 10 \mu\text{g Zn/l}$

As: 15% if $c > 1 \mu\text{g As/l}$
 25% if $c < 1 \mu\text{g As/l}$

Hg: 15% if $c > 0.01 \mu\text{g Hg/l}$
 25% if $c < 0.01 \mu\text{g Hg/l}$

5.3 Quality Assurance Plan

The quality assurance plan was first discussed at EMEP's workshop in Freiburg, Germany in 1986, and later distributed as a separate CCC report (EMEP/CCC-Report 1/88). The objectives of the quality assurance is to make sure that the data accuracy satisfy the DQO and to document the sites, the measurements, and the quality of the collected measurement data. It consists of the following elements:

- All the monitoring stations should meet the siting criteria defined in Section 2. Any deviations from these criteria should be documented, and their effect on the measurements examined.
- Instrumentation, standard operating procedures for sample collection and handling, chemical analyses and data reporting should be at hand, and documents describing the equipment and procedures should be available to the operators and technicians responsible for the sampling and chemical analysis, and to the EMEP QA Manager. These documented procedures should be

followed in detail. All the involved personnel should be properly trained and instructed. Duties and responsibilities should be specified.

- Field blanks and control samples should be included in the sampling and analysis series to document the accuracy, precision and detection limit, as described elsewhere in this Manual.
- Co-location sampling and measurements should be carried out, either with identical equipment to define the over-all precision of the measurements, or with different equipment to obtain information on the additional uncertainty due to sampling methodology. Non-standard sampling equipment or measurement methods should be compared with standard reference instrumentation and methods to define inter-network inconsistencies.
- Procedures should be developed to avoid gaps in the measurement series due to instrument breakdown. These procedures will involve preventive maintenance, supplies of spare parts, and replacement of instruments.
- A report of the quality assurance work at the national level should be prepared annually, covering the points mentioned above.
- System audits should be carried out at regular intervals to see that the instrumentation and sampling equipment is adequate, that sampling and chemical analysis is carried out according to specifications in this Manual, and to written procedures available at the sites and in the laboratories.

5.4 Measurement sites

The siting criteria are given in Section 2. Precautions to be undertaken with respect to the individual component are also described in the sampling part in Section 3.

5.4.1 Information about a monitoring site

Information about the EMEP site surroundings was presented in EMEP/CCC-Report 1/81. Since then a large number of new stations have been established.

Rather comprehensive forms for sites and site surroundings including distances to emission sources have been filled in and returned to the CCC. The key information collected is stored in the EMEP data base. The forms for this type of information will be revised as a part of the QA activity and the new forms will be simpler and less time-consuming to fill in.

The site information is available from CCC's homepage, <http://www.nilu.no/projects/ccc/network.html>.

5.5 Field and laboratory operations

5.5.1 Common guidelines for field and laboratory activities

When relevant for the measurements taken place in participating countries, the guidelines from the CCC should be translated before being passed on to the stations or laboratories.

The staff at the measurement sites and in the laboratories should have copies of the instructions for their work, their responsibilities and their delegated authority at hand. They should be familiar with these documents. The documents should be updated when needed.

The staff should be properly instructed before being assigned to the work, and should be given refresher courses at regular intervals, e.g. in combination with the national audits.

National resources should be sufficient to give the staff both in field and laboratory the equipment and accessories including spare parts and traceable standards, needed to perform their work in accordance with the EMEP quality assurance plan and recommendations.

Routines for handling, maintenance, and calibration of instruments and samplers at regular intervals, should be established, be at hand at the site and in the laboratories, and should be followed as intended.

Corrective routines should be established in order to have a high data completeness, and a stocks of the most used spare parts should be kept at the sites and in the laboratories.

Calibrations, maintenance etc. should be recorded in field journals and in laboratory journals. There should be one journal at hand next to each instrument.

It is strongly recommended that laboratories should apply for accreditation for compliance with EN 45001 or similar standards.

Any changes in instrumentation should be reported to the CCC.

5.5.1.1 Audits

Performance audits should be carried out by representatives of the technical staff from the institution operating the site once each year to see that the field operations work as intended. System audits should be carried out by the EMEP QA Manager in cooperation with the National QA Managers at regular intervals.

A detailed check-list to be filled in during these inspections should be worked out, and the WMO GAW check-list (WMO, 1994) may be used during audits of the wet deposition part of the measurements. The filled-in forms should be assessed by a scientist to ensure that the station operates as intended. The auditors should bring with them copies of the filled-in forms from the last visit when performing a site inspection. Corrective action should be taken immediately when necessary.

The system audits should:

- Check the quality system in general,
- inspect the sample locations and the site surroundings, and any changes since the last visit should be noted,
- follow the staff during their routines, and correct bad handling of equipment,
- check and calibrate the equipment and instruments,
- inspect the field journals,
- evaluate the need for improvements.

An audit plan and guidelines for the audit, should be worked out for this purpose.

5.5.2 Field operations

5.5.2.1 Instrumentation

Procurement of instrument or materials is the process of obtaining instruments and materials for field use, i.e. the instructions for contracting, purchasing, testing etc. The procurement procedures for instruments and materials should involve several quality assurance steps. The complexity and the number will usually be dependent upon how important the instrument or material is for the field operations.

Procurement has been treated by the US EPA (US EPA, 1976), procedures have for example been worked out for the Canadian Air and Precipitation Network (CAPMoN), see Vet and Onlock, 1983).

Each participant should have a preventive maintenance plan which covers all instruments used in the national network. The plan should list all instruments, the maintenance procedures for each instrument, and the preventive maintenance time schedule. The plan should further contain a list of replacement parts which may be needed, and a storage of tubes and other spare parts which easily can be changed at the site should be kept at the site in order to reduce the down period for instruments and to obtain a high data completeness.

The preventive maintenance should be carried out by the technical staff from the institution responsible for the site, or from the manufacturer of the instrument. Journals should be at hand for each instrument and records made for the preventive maintenance. Inspections for leaks in the tubes and connections should be a part of the daily sample exchange procedure. Low pressure readings in air sampling equipment may indicate leaks, and tubes appearing to be unclean need to be replaced with new tubes.

A calibration plan and calibration procedure covering the various instruments at the site must exist at all sites. For gaseous and aerosol components accurate volume readings are most important for the resulting measurements accuracy, and the volume meters may need frequent calibration. The accuracy of an air volume meter should be better than 5%. The results from the calibrations should also be kept in the journals. The need for calibration will normally be specified by the

manufacturer. As a general rule a calibration at least twice a year is desirable but should under no circumstances be less frequent than once every year. The institution responsible for the measurement may modify the calibration procedures or frequencies as more experience is gained with the instrument.

Written instructions for maintenance and calibration must be available at the site, and the operator should be familiar with the contents.

5.5.2.2 Changing of samples at the site

Detailed procedures for changing of samples for the recommended methods are parts of Section 2 in this Manual. Meter readings and other data of importance should be written into the field journal at the site, and copies of this information filled into the field reporting forms. Field reporting forms should follow the exposed samples and field blanks to the laboratory.

5.5.2.3 Sample storage and transportation

It is recommended to ship a one weeks supply from the laboratory to the site, and vice versa, once every week. There should be one blank sample every week.

Samples should be kept in a refrigerator, and once every week the field operator should fetch the seven exposed samples from the refrigerator as well as the one unexposed field blank, put the filter packs in the transportation box together with the site reporting form covering the past week. Field reporting forms should always be put in a separate plastic bag in case of accidental leaks from precipitation samples which may be contained in the same transportation box. In order to keep precipitation samples chilled during transportation, the boxes should be insulated and ice packs ("blue ice") follow the samples in the transportation boxes.

The samples should be kept in a refrigerator in the laboratory until the analysis is completed. The storage before the chemical analysis should in general be short. Aliquots of the samples should be stored for re-analysis until the quality checks of the data carried out at the responsible institutions are finished (e.g. three months).

Biological materials i.e. insects, leaves etc., and dust in precipitation samples will change the sample quality during storage and have an effect on the concentrations of hydronium ions, ammonium ions and other ion species in the sample. In order to detect any possible changes in the precipitation samples, pH or conductivity may be measured at the field site and compared with the results obtained after arrival in the laboratory. Samples which contain visual contamination should be filtrated in the laboratory as fast as possible.

5.5.2.4 Field blanks

A field blank sample is a sample which has been prepared, handled, and analysed as a normal sample in every way, except that it has not intentionally been exposed, and therefore should not contain the substance to be determined. Weekly field blank samples should be used in order to check possible sample contamination or sampling errors. Field blanks should be reported regularly to the

CCC. Detection limits for the measurements are calculated from field blanks. A procedure for calculation of detection limits is given in Section 5.5.

Field blanks may be unexposed filterpacks, absorption solutions, containers for precipitation etc. which are returned unexposed to the laboratory from the site and analysed. The blank samples should be handled and stored like normal samples and for the normal time periods.

Some precipitation collecting systems make use of reusable equipment which are cleaned in the field with deionized water every day when the sample has been collected. Errors may then very easily be introduced. In such systems it is particularly important to make use of field blanks by pouring a known amount of deionized water into the sampler after cleaning, immediately take it out of the sampler, handle and transport it to the laboratory, exactly like a normal precipitation sample.

It is also recommended to investigate the influence of dust and gases on the precipitation sample. This may be done on days when no precipitation has occurred the preceding 24 hours, at the time when the sample should have been collected (7-9 am local time), by adding a known amount of deionized water into the collector. This field blank should then be handled, stored and transported, as mention above.

5.5.2.5 Comparison of different field instruments

Different methods for sampling of air constituents and different collectors for rain and snow are used in the EMEP network today. The efficiency and performance of the various precipitation collectors depend upon the type of precipitation (rain, snow, etc.), wind speed, temperature, and a number of intrinsic factors related to the construction and design of the collectors.

In contrast to a precipitation collector one air sampler can collect only some of the components in the EMEP measurement programme, and more than one sampler has to be used.

The consequence of the large number of different samplers for gases, aerosols, and precipitation is that comparisons with a reference sampler are necessary in order to assess the differences in the results i.e. the between-network biases. Three large-scale field comparisons have been carried out for samplers of gaseous components and aerosols, and a deeper understanding of the differences and their causes has been gained. Nevertheless the experience shows that a quantitative relations are not easily obtained from these large experiments due to sampler problems and failure, and consequently too short data periods.

Comparisons should cover longer periods, preferably two years in order to catch different meteorological conditions. Only a smaller (random) selection of the samples need, however, to be analysed in order to obtain a reasonable basis for a quantitative estimate since EMEP has daily measurements. The comparisons should be performed with a reference sampler and a national sampler at one site in

each country. Results from these types of field intercomparisons can be found on <http://www.nilu.no/projects/ccc/>.

The problem with comparability also arises when changing from one type of air or precipitation sampler to another, within a participating country. The two collectors should therefore be run in parallel in the same way as briefly described above.

The recommended method for the calculations is taken from North American comparisons as described by Sirois and Vet (1994) in Section 5.6.1.

5.5.2.6 Precision of field instruments and measurement systems

Two identical samplers or collectors should be run in parallel over some period in order to assess the precision in the data. As above, it is recommended to allow a two year period of comparisons. Section 5.6.2 describes the calculations.

5.5.3 Laboratory operations

The chemical analysis of the samples should, as far as possible, not be divided between several institutions within one participating country in order at least to eliminate within-country inconsistencies.

The normal analytical laboratory procedures involve a series of precautions which have to be followed during the work in order to produce data with the required accuracy and precision. The precautions which seem to be specific to the recommended methods have been formulated in Section 4, Chemical analysis. More general aspects have been given in this Section in order to prevent unnecessary repetitions. Standard operating procedures should always be applied.

5.5.3.1 Chemical analysis

Calibration should be carried out in the beginning, and end of a series of samples, not to exceed 50, and at the end of the day at the latest. The average of the calibration before and after a sample series should be applied.

In order to quantify the precision and accuracy and detection limit in the laboratory:

- 5% of the samples should be split and the results used to quantify the analytical precision, for calculations of precision see Section 5.6.2,
- 5% of the samples should have known, and realistic, concentrations and should be run between the normal samples to control the performance of the analytical system,
- 5% of the samples should be blank samples used to quantify the analytical detection limit, for calculations of detection limit see Section 5.7.

5.6 Determination of accuracy

Accuracy of a chemical analysis in the laboratory is possible through internal checks against known concentrations and through the annual laboratory comparison exercises organized by the CCC (Hanssen and Skjelmoen, 1995). It is, however, in principle not possible to assess the accuracy in air concentration measurements carried out at a site when accuracy is defined as the deviation from the true, and unknown, concentration. Even the comparability of the data is a severe problem with a widespread monitoring network involving a large number of different sampling methods and laboratories. It is, however, possible to determine the systematic errors (bias) relative to a reference measurement system and also to determine the precision of the measurements. The bias relative to a standard system and the precision together determines the uncertainty of the measurements and will when assessed through the network, and used together with the routine data, give a comparable data set.

The basis for the assessment is parallel sampling, either by one reference method and one national measurement system giving the (relative) bias, or by running two identical national measurement systems giving the precision.

The samples should cover all seasons, and the experiment should preferably extend over two years in order, to some extent, represent different measurement conditions. For an evaluation of the results, however, only a selection of the samples needs to be analysed, and one or two samples every week selected at random may give a sufficient number of samples for an annual average. By selecting samples at random, possible systematic effects on the results from source differences during weekends compared to working days will be reduced. It will also reduce the autocorrelation in the data which simplifies some types of statistics. The bias and random errors in the measurements must be expected to depend upon several factors and the analysis of the data may necessitate a stratification of the material and more than one estimate of the bias difference or precision to be given, e.g. different results for each season. An inspection of the blanks including visualization in charts is strongly recommended before starting the calculations. For Canadian precipitation data Sirois and Vet (1994) concluded that precipitation depth, precipitation type, concentrations, location as well as season and year all influenced the precision. In this case a larger number of samples than indicated above may be necessary.

5.6.1 Determination of systematic errors

The basis for the assessment of the systematic errors (bias) relative to a reference analytical chemical method or a reference measurement system, e.g. the between-network bias, is the parallel sampling between two systems.

The importance of standard operating procedures which enables a reproduction of results should be emphasized once more, without them, clearly an effort with parallel sampling is wasted.

Following Sirois and Vet (1994) the overall difference between two measurement systems can be described by the average or median of the differences, the

variability in the differences through the modified median absolute difference estimator (M.MAD), and the coefficient of variation (CoV).

A simple model is applied for the measurements:

$$C_i^l = T_i + B_i^l + e_i^l$$

$$C_i^r = T_i + B_i^r + e_i^r$$

C_i^l and C_i^r are the concentrations obtained with the local or national measurement system and with the reference system respectively, in sample (day) i . T_i is the true and unknown concentration of the component examined which is independent of the measurement system applied. B_i^l and B_i^r are the possible biases in the two systems in sample i , and e_i^l and e_i^r contain the random errors in the data which are reflected in the precision. The random errors e_i are both assumed to have mean values equal to zero while the mean values of both B_i in general are different from zero.

The difference between the two measurements a specific day i gives:

$$C_i^l - C_i^r = (B_i^l - B_i^r) + (e_i^l - e_i^r)$$

and the average difference between the systematic errors for a year, or in a stratum, e.g. during the winter season, can be calculated. Assuming an average over a sufficient number of samples, the averages of the random errors e_i will approximate zero

$$\bar{D} = \frac{l}{n} \sum (C_i^l - C_i^r) = \frac{l}{n} \sum (B_i^l - B_i^r) + (0)$$

and the average of the differences, \bar{D} , between the systematic errors be assessed.

The arithmetic average is often replaced by the median of $C_i^l - C_i^r$ because the statistical distribution of the data frequently deviate from a normal distribution and the median is not influenced by a few extremely large or small measurements.

When $\varepsilon_i^{lr} = C_i^l - C_i^r$, the definition of M.MAD and CoV are

$$M.MAD = \frac{1}{0.6756} \text{median} \left(\left| \varepsilon_i^{lr} - \text{median} \left(\varepsilon_i^{lr} \right) \right| \right)$$

$$\text{CoV} = \frac{\text{median} \left(\varepsilon_i^{lr} \right)}{\text{median} \left(C_i^r \right)}$$

The calculations should not include measurements which are considered to be extreme. Such results indicate a measurement problem which needs to be solved.

The experiment has to be repeated for all countries taking part in the network using the same standard measurement system as reference. Assuming that bias differences between sites within a country can be disregarded a correction of annual averages, or averages of possible strata as indicated above, of the routine data can be carried out.

It is necessary to complement the calculations on the parallel measurements with charts such as scatter plots and often also to include other statistical methods to further investigate the differences which may occur.

5.6.2 Determination of precision

The precision in the total measurement is more useful for a data user as a measure of the random errors than is the laboratory precision. The basis for an estimation of the measurement precision is a parallel sampling with two identical measurement devices following identical sampling and analytical procedures.

Several measures of precision may be used, e.g. the modified median absolute difference (M.MAD) which is used in the preceding section (Vet and McNaughton, 1994; Sirois and Vet, 1994) and which we will use. This is an estimator of the spread in the data which becomes equivalent to the standard deviation for normal distributions. In the latter case about 68 per cent of the data will be within one standard deviation from the average. The M.MAD is as in the preceding section based on the median of the differences between the corresponding measurements (i.e. usually daily results) which will be insensitive to the presence of a few extreme values.

The equations are similar to the ones in the preceding section. The statistical model for the measurements is given by

$$C_i^1 = T_i + B_i + e_i^1$$

$$C_i^2 = T_i + B_i + e_i^2$$

i is the sample number and C_i^1 the concentration obtained with one of the sampling systems. The true value day i is T_i , and the bias, assumed to be identical for the two measurement systems, is B_i . The random error is contained in e_i^1 which has mean value zero. The precision is then described by the spread in e_i . Assuming that e_i from each of the two samplers are drawn from the same distribution:

$$e_i = \frac{1}{\sqrt{2}} (C_i^1 - C_i^2) \text{ or}$$

$$e_i = \frac{1}{\sqrt{2}} (e_i^1 - e_i^2)$$

The factor in front of the parentheses is included because the errors e_i in the two measurements are assumed drawn from identical distributions.

$$M.MAD = \frac{1}{0.6745} \text{median} (|e_i - \text{median}(e_i)|)$$

The factor 1/0.6745 has been included to make the M.MAD equal the standard deviation for normal distributions.

The coefficient of variance is defined as

$$\text{CoV} = \frac{\text{M.MAD}}{\text{median}(\bar{C}_i)}$$

and where \bar{C} is the average of the two corresponding (usually daily) results.

$$\bar{C}_i = \frac{1}{2} (C_i^1 + C_i^2).$$

5.6.3 Calculation example for precision

The example below is from a series of parallel measurements of aldehyde/ketones carried out during the winter 1994–1995 at the Birkenes site (NO 1) in Norway. The methods for sampling and analysis are described elsewhere in this Manual, and the data are the concentrations of acetone (propanone). Volatile organics are sampled twice weekly in EMEP, usually Tuesdays and Thursdays.

The Tables 5.6.1 and 5.6.2 present the resulting precision expressed by the modified median absolute deviation (M.MAD) and the coefficient of variance (CoV) making use of the formulas in the preceding section with a spreadsheet as a basis for the calculations. The “Median (H)”, in the rightmost column of Table 5.6.2, gives the M.MAD when divided by 0.6745, and the CoV is obtained by division of the M.MAD with the “Median (\bar{C})” and multiplying with 100 in order to have the result in per cent.

Table 5.6.1: Precision of acetone measurements expressed by the modified median absolute deviation M.MAD, and the coefficient of variance CoV.

M.MAD $\mu\text{g}/\text{m}^3$	CoV per cent
0.042	4.5

Table 5.6.2: Calculation of precision. The two leftmost columns contain the 8-hour averages of acetone from two parallel measurements.

S 1 = Birkenes 1	S 2 = Birkenes 2	$\bar{C} = \frac{(S1 + S2)}{2}$ Average		D = S1 - S2 Difference	$E = \frac{D}{\sqrt{2}}$	F =	G = E - F	H = G	
1.57	2.49	2.030	Median (C)	-0.92	-0.6505	Median (E)	-0.6293	0.6293	Median (H)
1.37	1.42	1.395	= 0.9300	-0.05	-0.0354	= -0.0212	-0.0141	0.0141	= 0.0283
2.27	2.41	2.340		-0.14	-0.0990		-0.0778	0.0778	
2.16	2.23	2.195		-0.07	-0.0495		-0.0283	0.0283	
1.48	1.52	1.500		-0.04	-0.0283		-0.0071	0.0071	
4.09	4.22	4.155		-0.13	-0.0919		-0.0707	0.0707	
0.93	0.89	0.910		0.04	0.0283		0.0495	0.0495	
1.21	1.24	1.225		-0.03	-0.0212		0.0000	0.0000	
1.41	1.45	1.430		-0.04	-0.0283		-0.0071	0.0071	
3.54	2.46	3.000		1.08	0.7637		0.7849	0.7849	
1.80	1.94	1.870		-0.14	-0.0990		-0.0778	0.0778	
2.31	2.21	2.260		0.10	0.0707		0.0919	0.0919	
1.39	1.42	1.405		-0.03	-0.0212		0.0000	0.0000	
1.36	1.45	1.405		-0.09	-0.0636		-0.0424	0.0424	
0.81	0.90	0.855		-0.09	-0.0636		-0.0424	0.0424	
0.93	0.97	0.950		-0.04	-0.0283		-0.0071	0.0071	
0.69	0.76	0.725		-0.07	-0.0495		-0.0283	0.0283	
0.78	0.84	0.810		-0.06	-0.0424		-0.0212	0.0212	
0.57	0.56	0.565		0.01	0.0071		0.0283	0.0283	
0.78	0.83	0.805		-0.05	-0.0354		-0.0141	0.0141	
0.86	0.96	0.910		-0.10	-0.0707		-0.0495	0.0495	
0.63	0.74	0.685		-0.11	-0.0778		-0.0566	0.0566	
0.66	0.63	0.645		0.03	0.0212		0.0424	0.0424	
0.56	0.56	0.560		0.00	0.0000		0.0212	0.0212	
0.60	0.65	0.625		-0.05	-0.0354		-0.0141	0.0141	
1.01	1.00	1.005		0.01	0.0071		0.0283	0.0283	
0.54	0.55	0.545		-0.01	-0.0071		0.0141	0.0141	
0.63	0.63	0.630		0.00	0.0000		0.0212	0.0212	
0.75	0.73	0.740		0.02	0.0141		0.0354	0.0354	
1.00	0.95	0.975		0.05	0.0354		0.0566	0.0566	
0.55	0.51	0.530		0.04	0.0283		0.0495	0.0495	
0.41	0.44	0.425		-0.03	-0.0212		0.0000	0.0000	
0.42	0.44	0.430		-0.02	-0.0141		0.0071	0.0071	
0.62	0.62	0.620		0.00	0.0000		0.0212	0.0212	
0.87	0.93	0.900		-0.06	-0.0424		-0.0212	0.0212	
0.95	0.95	0.950		0.00	0.0000		0.0212	0.0212	
1.14	0.94	1.040		0.20	0.1414		0.1626	0.1626	
1.53	1.54	1.535		-0.01	-0.0071		0.0141	0.0141	

The temporal variation of the two parallels is given in Figure 5.6.1, and Figure 5.6.2 contains a scatterplot of the results.

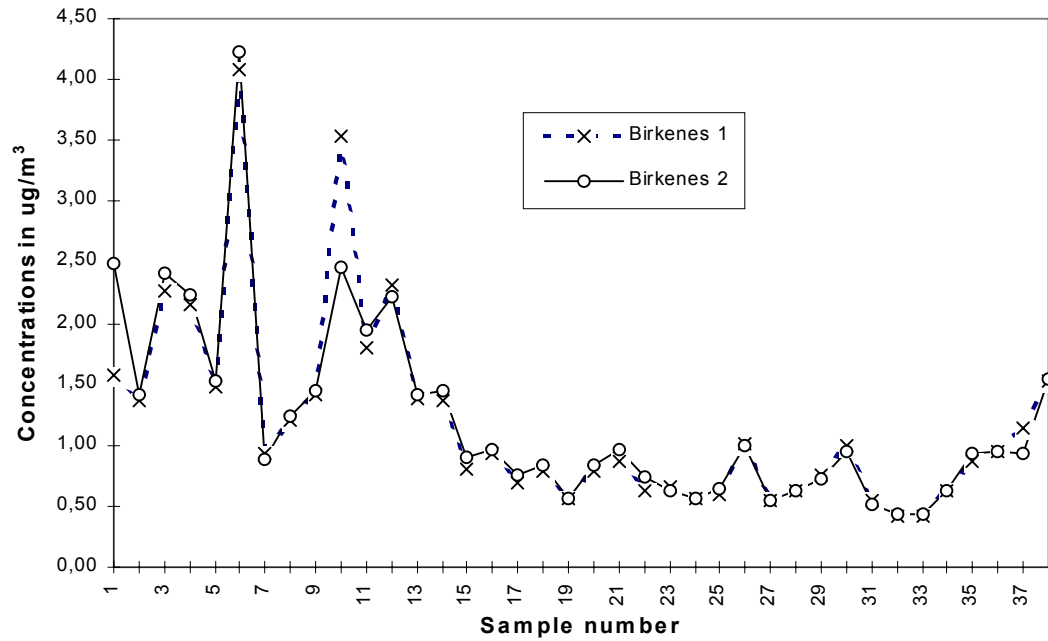

Figure 5.6.1: Temporal variation of acetone during the winter 1994–1995 at Birkenes (NO 1), measured in two parallels. Units in $\mu\text{g}/\text{m}^3$.

The correspondence is generally very good in the Figure above except for the results from sample pair 10 where a mistake has been made with one of the parallels.

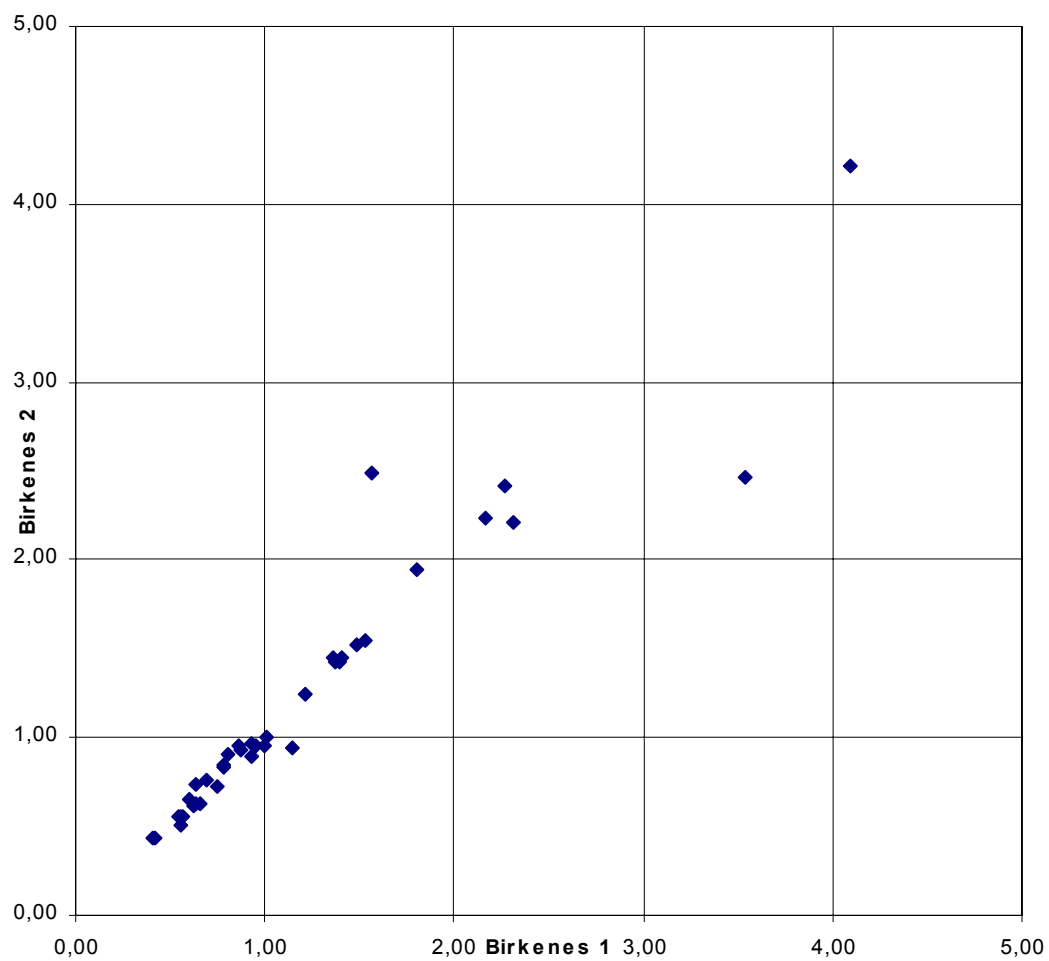

Figure 5.6.2: Scatterplot of the two parallel measurements of acetone at Birkenes (NO 1) during the winter 1994–1995. Units in $\mu\text{g}/\text{m}^3$.

5.7 Calculation of detection limit

Different definitions of detection limits can be found in the literature, and in the preliminary version of this manual, a statistical method after Currie (1968), Wilson (1973), and Kirchmer (1983) was described. One common definition of the detection limit is important because it will highly ease the use of the data, and also simplify the data documentation. As a result of discussions, and a desire to harmonize with WMO GAW, a method different from the one above was selected in the end. The method below and the method described by Currie (1968) and others, are both based on normal distributed data, and the numeric difference in the resulting detection limits comes from a different factor to be multiplied with the standard deviation. The method described by Currie (1968) will in our case give a detection limit about fifty percent higher than the one defined below.

In order to make a detection limit relevant to a complete measurement process, it must be calculated from field blank samples.

It should be emphasized that when concentrations become less than the detection limit, the calculated concentrations should still be reported when possible, and not given as “less than the detection limit”. A data user should normally be able to take such data into account, and at the same time be aware of their limitation.

5.7.1 Basic assumption

The reported EMEP data are assumed to be the differences between measurements made on normal exposed samples and blanks e.g. field blank samples. A field blank sample is defined as a sample which has been prepared, handled, transported, and analysed as a normal sample in every way, except that it has not intentionally been exposed, and therefore should not contain the substance to be measured.

The blank values should be aggregated to averages before used to correct measurement results. A possible seasonal variation of blank samples needs to be investigated, and if a variation is present, the blank samples should be aggregated as seasonal or half-yearly averages or better medians, rather than as annual averages before used in corrections.

Unexpected high blank values point at a measurement problem which has to be identified and solved. Such blank values shall not be used for corrections of measurements and calculations of detection limits. The related measurement results must be flagged as less accurate than normal. As an alternative to a complete rejection of the outliers, a “Winsorization” procedure is recommended.

It is assumed that the distribution of the blanks does not deviate too much from a normal distribution.

5.7.2 Statistical considerations

5.7.2.1 Data distribution

It is well known that air pollution data have skew distributions, usually closer to lognormal than to normal distributions. It was assumed above that the data have approximate normal distributions. This is a frequently made assumption when detection limits are discussed and simple statistics based on normal distributions give generally reasonable results even if the distribution is not normal in a strict sense.

The example presented in Figure 5.7.1 is based on field blanks of sulphur dioxide on impregnated filters from the Birkenes site in Norway in 1994. The distribution looks bimodal due to a pile up of blanks in the low-concentration end, around and partly below the detection limit of the analytical method applied (ion chromatography). This distribution is, however, accepted as a sample from a normal distribution when tested with Kolmogorov-Smirnov statistics. This only illustrates that assumptions about normal distributions of the blanks may be reasonable, although not generally valid.

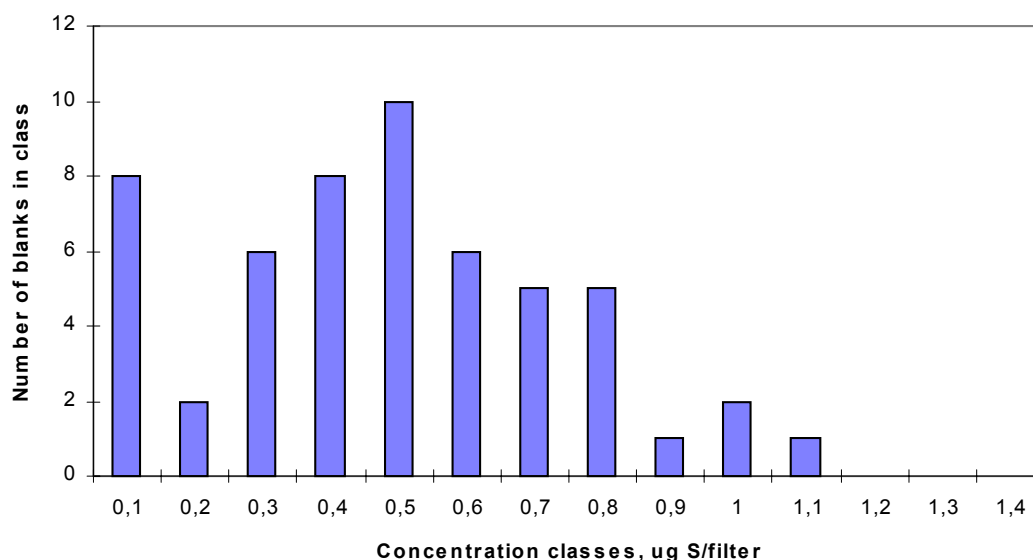

Figure 5.7.1: Frequency of field blanks for SO_2 at Birkenes in 1994.
Unit: $\mu\text{g S/KOH}$ impregnated filter.

5.7.2.2 Detection limit

The detection limit is taken to be three times the standard deviation of the blank results. The probability for having a blank of his size is less than 0.5 per cent.

The detection limit can be calculated:

$$L_d = 3.0 \cdot S_b$$

where the standard deviation is defined as

$$s_b = \left(\frac{1}{N-1} \sum_{i=1}^N (C_i - \bar{C})^2 \right)^{1/2}$$

N is the number of field blanks, C_i is the concentration of the relevant substance in the i^{th} field blank and \bar{C} is the field blank average after elimination of “extreme” blank values. M is the median value.

$$\bar{C} = \frac{1}{N} \cdot \sum_{i=1}^N C_i$$

5.7.2.3 Winsorization procedure

The following procedure may be followed to “Winsorize” outliers, e.g. see Gilbert (1987). The outliers may be identified by inspection and experience rather than by statistical procedures.

As an example, the occurrence of 2 extremely high blank values is assumed.

- Replace the 2 extreme high values with the next lower value.
- Replace the 2 lowest values with the next higher value.
- Calculate the average and the standard deviation of the new data set following Section 5.7.2.2.
- Calculate the Winsorized standard deviation.
- Apply the Winsorized standard deviation to calculate L_d in Section 5.7.2.2.

The Winsorized standard deviation, S_w , is

$$S_w = \frac{S_b (n-1)}{v-1}$$

where n is the number of blanks, S_b is the standard deviation of the new data set after the replacements described above. The number of data not replaced, $v = n-2k$, with k outliers (k is 2 in the example above).

5.7.3 Calculation example for air samples

Figure 5.7.1 present field blank results for sulphur dioxide measurements at Birkenes (NO1) in 1994. The unit is $\mu\text{g S/filter}$, the typical air volume is 24 m^3 , a normal air volume with the type of equipment used (NILU EK air sampler) at Norwegian sites. A one weeks supply of filterpacks is sent to the site every week and returned and analysed after one week. Figure 5.7.2 shows the variation of the concentrations of sulphur dioxide in the field blanks through 1994. It is recommended to perform a separate calculation for each quarter.

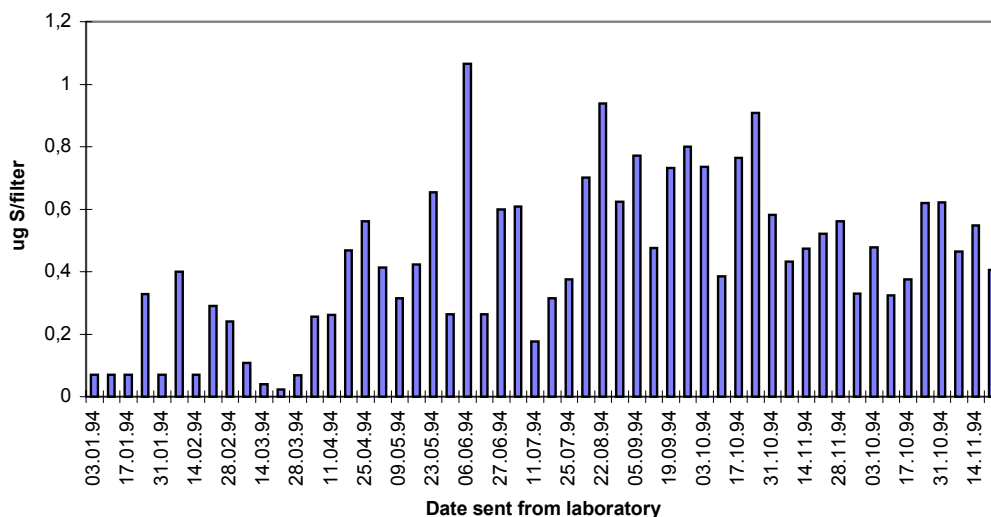

Figure 5.7.2: SO₂ field blanks from Birkenes in 1994.

The results obtained with the data presented in Figure 5.7.2 are given in Table 5.7.1, based on 24 m³ air/day.

Table 5.7.1: Blank results and detection limits for SO₂ at Birkenes in 1994.

	jan-mar		apr-jun		jul-sep		oct-dec	
	µg/filter	µg/m ³	µg/filter	µg/m ³	µg/filter	µg/m ³	µg/filter	µg/m ³
\bar{C}	0.149	<0.01	0.418	0.02	0.574	0.02	0.544	0.02
S _b	0.129	<0.01	0.258	0.01	0.222	0.01	0.166	<0.01
M	0.071	<0.01	0.364	0.02	0.609	0.03	0.521	0.02
L _D	–	0.02	–	0.03	–	0.03	–	0.02

5.8 Training of personnel

Training courses may be organized by the CCC in cooperation with other institutions.

5.8.1 Training of station personnel

Proper training and instruction of site operators is of great importance of the data quality, and all new operators should receive their instructions directly from the scientist responsible for the performance of the station. The training and instruction should take place at the actual measuring station, if necessary after some basic instructions at the laboratory. The operators responsibilities at the site must correspond with his/hers technical qualifications, and the operation of complicated sampling equipment may require technical education.

5.8.2 Training of laboratory personnel

Laboratory personnel should be properly trained in sample handling and analytical work before they are allowed to carry out the routine analyses. Before being assigned on a routine basis to new instruments or methods, they should preferably work on split samples in order to ensure that the requirements to precision and accuracy are met.

5.9 References

- CEN (1989) General criteria for the operation of testing laboratories. Brussels (EN 45001).
- EMEP (1995) The status of monitoring within EMEP: Quality of measurements and data completeness. Monitoring strategy. Kjeller, Norwegian Institute for Air Research (EMEP/CCC-Note 3/95).
- EURACHEM/WELAC Chemistry Working Group Secretariat (1993) Accreditation for chemical laboratories. Guidance on the interpretation of the EN 45000 series of standards and ISO/IEC Guide 25. Teddington, United Kingdom (WELAC WGD 2/EURACHEM GD 1).
- Gilbert, R.O. (1987) Statistical methods for environmental pollution monitoring. New York, Van Nostrand Reinhold.
- Hjellbrekke, A.G., Lövblad, G., Sjöberg, K., Schaug, J. and Skjelmoen, J.E. (1995) Data Report 1993. Part 1: Annual summaries. Kjeller, Norwegian Institute for Air Research (EMEP/CCC-Report 7/95).
- ISO (1990) General requirements for the competence of calibration and testing laboratories. Geneva (ISO/IEC Guide 25).
- ISO (1994) Quality management and quality assurance standards. Part 1: Guidelines for selection and use. Geneva (ISO 9000-1).
- ISO (1994) Quality management and quality assurance vocabulary. Geneva (ISO 8402).
- ISO (1994) Quality management and quality system elements. Part 1: Guidelines. Geneva (ISO 9004-1).
- ISO (1991) Quality management and quality system elements - Part 2: Guidelines for services. Geneva (ISO 9004-2).
- ISO (1993) Quality management and quality system elements - Part 4: Guidelines for quality improvement. Geneva (ISO 9004-4).
- Hanssen, J.E. and Skjelmoen, J.E. (1995) The fourteenth intercomparison of analytical methods within EMEP. Kjeller, Norwegian Institute for Air Research (EMEP/CCC-Report 3/95).
- Schaug, J. (1988) Quality assurance plan for EMEP. Lillestrøm, Norwegian Institute for Air Research (EMEP/CCC-Report 1/88).

- Sirois, A. and Vet, R.J. (1994) Estimation of the precision of precipitation chemistry measurements in the Canadian air and precipitation monitoring network (CAPMoN). In: *EMEP Workshop on the accuracy of measurements. Passau, 1993*. Edited by T. Berg and J. Schaug. Kjeller, Norwegian Institute for Air Research (EMEP/CCC-Report 2/94). pp. 67-85.
- Sirois, A. and Vet, R.J. (1994) The comparability of precipitation chemistry measurements between the Canadian air and precipitation monitoring network (CAPMoN) and three other North American networks. In: *EMEP Workshop on the accuracy of measurements. Passau, 1993*. Edited by T. Berg and J. Schaug. Kjeller, Norwegian Institute for Air Research (EMEP/CCC-Report 2/94). pp. 88-114.
- Vet, R.J. and McNaughton, D. (1994) The precision, comparability and uncertainty of air and precipitation chemistry measurements made during the Canada-United States Eulerian Model Evaluation Field Study (EMEFS). In: *EMEP Workshop on the accuracy of measurements. Passau, 1993*. Edited by T. Berg and J. Schaug. Kjeller, Norwegian Institute for Air Research (EMEP/CCC-Report 2/94). pp. 115-134.
- WMO (1992) Report of the WMO meeting of experts on the quality assurance plan for the Global Atmosphere Watch. Garmisch-Partenkirchen, Germany, 26–30 March 1992. Geneva (WMO/GAW No. 80).
- WMO (1994) Report of the workshop on precipitation chemistry laboratory techniques. Hradec Kralove, Czech Republic, 18–21 October 1994. Edited by V. Mohnen, J. Santroch and R. Vet. Geneva (WMO/GAW No. 102).

6. Data handling and data reporting

6.1 Data checking

Data checking or validation is based upon:

- experience with the data from earlier measurements,
- relations between chemical components in air and precipitation,
- knowledge about spatial variation,
- knowledge about temporal variation,
- comparisons between measurements and estimates from theory or models.

Records of old data can be used to create simple statistics including percentiles, mean values and standard deviations. Log-transformed data are often preferred. These statistics can be used in connection with control charts or in other comparisons of new data with aggregation of the old ones.

Relations between various chemical components should be utilized, this includes ion balances, relations between sea salt components, and relations between constituents in minerals and dust from other sources. Comparisons with measurements from neighbour stations can be useful, and plots of time-series, e.g. 4-5 year long series of monthly averages of each component can give indications about measurement problems. Estimates of conductivity should be compared with the measured ones. When pH is higher than 5-6 weak acids, which normally are not measured, will be present in the sample. This is a frequent problem in connection with precipitation samples at many EMEP sites.

In this case the ion balance test and comparisons with conductivity will fail unless the missing anions are measured, i.e. through titrations. It should additionally be noted that the equivalent conductivity of the hydronium ion is much higher than those of the other ions, and that a conductivity test of an acidic sample therefore tends to be a test on the pH determination.

6.1.1 *Statistical tests*

The statistical tests compare new measurements with data already stored in the data base. The tests are carried out to identify possible outliers and results which may be wrong. They can be based upon assumptions about the data distributions i.e. a lognormal distribution, or they can be based on comparisons with cumulative frequency distributions.

Gaseous, aerosol or precipitation components may be compared with all earlier data for each component making use of lognormal distributions. The data should then be split into data from different seasons or into winter and summer data. Data outside three or four times the standard deviations should be inspected manually by comparison with other components, concentrations the preceding and following days, and concentrations at neighbouring stations.

The distributions of the different types of data may deviate from a theoretical lognormal distribution. The deviation may be particularly notable in the low

concentration part of the distribution where all concentrations less than the detection limit will have to be set equal to a small value. Since the tests are used only to identify measurements which should be inspected more closely, minor deviations from a theoretical distribution function can be accepted.

One way to test if a set of data in fact follows a theoretical distribution function is to make use of the Kolmogorov-Smirnov one-sample, two-tailed test (Siegel, 1956).

Other useful statistical textbooks are Gilbert (1987) and Conover (1980).

6.1.2 Ion balance

The EMEP precipitation programme includes all main components in precipitation, and the difference of positive and negative ion concentrations expressed in microequivalents per litre should therefore be zero. Alternatively, the ratio between the anion and cation concentrations expressed in microequivalents per litre should be close to one.

The effect of minor components e.g. phosphates and organic acids, which are not included in the analysis, is usually negligible in acid precipitation.

Assuming equilibrium between carbon dioxide in air and carbonic acid in precipitation, the bicarbonate concentration is negligible when the pH is below 5 and will only contribute 5 e/l at pH=6. Bicarbonate ions dissociate into carbonate ions, but this is negligible below pH=8.

When pH is above 6 in a precipitation sample, experience shows that there apparently is present a large excess of anions in the sample which can not be accounted for. This may be the case even if the bicarbonate concentration, calculated from simple equilibrium conditions, are added.

The weak or strong acids were determined by a titration in the start of EMEP, and these results revealed for some sites large differences between the weak acid concentration measured and the bicarbonate concentrations as calculated from pH assuming equilibrium. It is possible that precipitation samples sometimes are supersaturated with carbon dioxide and therefore may contain more bicarbonate than expected. Clearly, if the pH in precipitation samples at a site frequently is above 6, a titration of the acid concentration should be performed on a routine basis in order to be able to control the precipitation data quality.

During storage, soil dust, organic material etc. may be dissolved or biological processes may occur under unfavourable conditions. Deviations in the ionic sum from zero may indicate this.

The ionic balance check should be carried out as soon as possible, while the chemical analysis can still be repeated. The DGO in Section 5.2 has 10–15% laboratory accuracy as target for the main components in precipitation. As a general guideline, based upon the difference and the sum of cation and anion concentrations, the ion concentration difference in per cent of the ion

concentration sum should be lower than 10–15% (except for samples with ion sums below 50 $\mu\text{e/l}$). If a complete chemical analysis is performed, the ionic balance test is equally useful for aerosol samples.

6.1.3 Conductivity

The conductivity of the precipitation samples should be measured, and compared with values calculated from the measured concentrations by adding the equivalent ionic conductivities. The conductivity measurements should be carried out at 25 °C. A correct determination of conductivity will reveal whether the ion concentration sum is too low or too high. When combined with ion balance calculation and other information, e.g. relations between sea salt components at marine influenced sites, it will identify a smaller group of components which are wrong.

It should be noted, however, that at low pH values ($\text{pH} < 4.0$) the conductivity of the solution will be dominated by the hydrogen ions. Errors in the concentrations of other ionic species will then not be easily detected.

Since this test is based on the ion concentrations as is the ionic balance test, the same limitations as above occur for $\text{pH} > 6$.

6.1.4 Calculation of ion balance and conductivity

Explanation of symbols

(A) Concentration of element A in mg/l. Primary precipitation parameter as reported in data base.

[A] Concentration of element A in $\mu\text{e/l}$ (micro-equivalents per litre). Used in computation of ionic sums and conductivity.

E_A Equivalent weight for ion species A in g/l.

F_A Equivalent ionic conductivity for ion species A in $\text{mho/cm} = \frac{\text{S}}{\text{cm}}$ (S = Siemens).

The equivalent conductivity F_A expresses the conductivity due to one equivalent of A per litre.

Conversion of concentration

To convert from (A) to [A] the following formula is used:

$$[A] = \frac{(A) \cdot 1000}{E_A} \quad (1)$$

The equivalent weight E_A for different ion species are given in Table 6.1.1 below.

It is seen from this table that parameter 4, H^+ , is an exception. It is reported in the unit $\mu\text{e/l}$ in the data base. Formula (1) is never applied to this species.

Table 6.1.1: Equivalent weights (E_A) and equivalent ionic conductivities (F_A) at infinite solution and 25°C for different species (WMO-GAW Report 85, CRC, 1985–1986).

Species	E_A	F_A
SO ₄ ²⁻ -S	16.0	80.0
SO ₄ ²⁻ -S (corr)	–	–
H ⁺	–	349.7
NH ₄ ⁺ -N	14.0	73.5
NO ₃ ⁻ -N	14.0	71.4
Na ⁺	23.0	50.1
Mg ²⁺	12.2	53.0
Cl ⁻	35.5	76.3
Ca ²⁺	20.0	59.5
pH	–	349.7
K ⁺	39.1	73.5
HCO ₃ ⁻	–	44.5

- Sulphate corrected for sea-salt is not used in computations of ionic sums and conductivity.
- is reported in µe/l, not in mg/l as for the other precipitation species. Thus no conversion factor E_A is given.
- pH cannot be used directly in conductivity computations. First [H⁺] is computed from pH. This value is then used with the F_A given for pH in the conductivity computations.
- Bicarbonate, HCO₃⁻, is not a primary parameter in the data base. This is also computed from pH before computation of specific conductivity.

Sum of positive ions

The formula is:

$$ISP = [H^+] + [NH_4^+-N] + [Na^+] + [Mg^{2+}] + [Ca^{2+}] + [K^+] \quad (2)$$

If H⁺ is measured by titration and is negative, it is set to zero in this computation (refer to the section on weak acids below).

If H⁺ is not measured, but pH is determined with a legal value (pH > 0), the [H⁺] is substituted by:

$$[H^+_{comp.}] = 10^{(6.0-pH)} \quad (3)$$

The remaining elements in formula (2) are computed by formula (1) if the species are reported, and otherwise set to zero.

Weak acids

If $[H^+]$ determined through a titration is negative, it no longer reflects the concentration of strong acids in the precipitation. Instead it now reflects the sum of concentrations of various weak acids, including the bicarbonate ion, HCO_3^- . When this condition is found, the following two steps are taken before ionic sums are computed:

$$[\text{Weak acids}] = -[H^+] \quad (4)$$

$$[H^+] = 0 \quad (5)$$

Sum of negative ions

The basic formula is:

$$ISN = [\text{Weak acids}] \text{ or } [HCO_3^-] + [SO_4^{2-}\text{-S}] + [NO_3^-\text{-N}] + [Cl^-] \quad (6)$$

In this expression $[\text{Weak acids}]$ is defined by formula (4) above.

If $[\text{weak acids}]$ is not measured, the $[HCO_3^-]$ is taken into the calculation if $pH > 5.0$.

$$[H^+_{\text{comp.}}] = 10^{(6.0-pH)} \mu\text{e/l} \quad (3)$$

$$[HCO_3^-] = \frac{5.1}{[H^+_{\text{comp.}}]} \mu\text{e/l} \text{ (Topol et al., 1985)} \quad (7)$$

The remaining elements in (6) are computed by formula (1) if the corresponding species are reported.

Conductivity

The basic formula for the conductivity is:

$$\text{Cond} = 10^{-3} \cdot \sum_A [A] \cdot F_A \frac{\mu\text{S}}{\text{cm}} \quad (10)$$

The expression $[A]$ is as before computed by formula (1).

6.1.5 Use of time series plots in data checking

PCs and Unix systems have made graphical possibilities easy accessible which should be utilized in the data control. Although errors should be detected at an much earlier stage, plots of monthly average concentrations in three or four year long series, have revealed errors in EMEP data. This is strongly recommended as an additional test. Plots of daily concentrations or precipitation amounts should likewise be a part of the routine. The plots should be compared with historical data divided into half-yearly, seasonal or even monthly aggregates. From the historical data good sets of 5- and 95-percentiles can be calculated since EMEP

now possesses a vast amount of data. Data outside these limits should be inspected more closely as a routine.

6.1.6 Other methods for data check

Relations between components which are connected, e.g. sea salt components, should be utilized.

6.2 Rejection of data

No data should be rejected automatically by use of a computer programmes alone; manual inspection should always be carried out before this step is taken.

The purpose of the EMEP is to provide information about air pollution from distant anthropogenic sources, natural pollution and sources within the region (as far as this is in consistence with the criteria given for site location).

Data carrying other types of information, e.g. contaminated samples or careless handling of samples etc., should only be accepted in the data base when the effect of the contamination is considered to be negligible. These data need to be flagged.

6.3 Classification of precipitation samples

The QA plan for EMEP (EMEP/CCC Report 1/88) and the draft version of this Manual contained a classification of precipitation sample results based on ion balance tests and comparisons between measured and estimated conductivities. Having introduced Data Quality Objectives in EMEP, it seems reasonable to base a classification on the criteria given in Section 5.2. The classification given in the two previous reports should therefore not be used, and a new classification will be worked out for the next revision of this Manual.

6.4 Data flags

Several flags have in the past been used to give information about the quality of the data stored in the data base. These flags are revised and are currently under evaluation. The new data flag system contain the old flags, and it will be extended at need.

Some EMEP sites are located at the coast and are from time to time highly exposed to sea salt particles. This will of course affect several components in precipitation which should be flagged in the data base. In particular the “excess sulphate” in precipitation, which will be the difference between two large numbers, may have a high uncertainty and should be flagged.

The person responsible for the data reporting in each participating country is the data originator (DO). The DO will have access to NILU’s external computer and will take care of the future data transfer to the central data base at the CCC.

Flags are sorted according to severity. Flags above 250 indicate an exception that has invalidated or reduced the quality of the data element.

Flags below 250 indicate that the element is valid, even if it may fail simple validation tests. The value may for example be extreme, but has been tested and found correct.

The flag 100 is used to indicate that a value is valid even if an exception in the 999-250 range has also been flagged. In this case the 100 flag must appear before the other flags. In all other cases, the most severe flag should appear first if more than one flag is needed.

All flags are grouped in two categories: V (valid measurement) or I (invalid measurement).

6.4.1 Group 9: Missing

When a measurement is missing and no particular information is available, we cannot assign any numerical value to the measurement (no substitution value is applicable). The measurement value must have been replaced with the transfer file missing flag. For all flags in this group, the measurement is irrecoverably lost, and no substitution value may be computed or estimated. The DO assigns one of the following flags in the flag variable (in addition to setting the transfer file missing flag):

Flag Mnemonic	V/I	Description
999 MMU	I	Missing measurement, unspecified reason
990 MSN	I	Precipitation not measured due to snow-fall. Needed for historic data, should not be needed for new data
980 MZS	I	Missing due to calibration or zero/span check

6.4.2 Group 8: Undefined

In some cases a measurement may not be performed because the parameter to be measured is not defined. As mentioned above, the concentration of pollutants in precipitation is undefined when there is zero precipitation. In this situation the measurement is not missing, and the data availability is not reduced. It is not possible to compute or estimate a substitution value for a measurement that is undefined. The DO assigns one of the following flags:

Flag Mnemonic	V/I	Description
899 UUS	I	Measurement undefined, unspecified reason
890 UNP	I	Concentration in precipitation undefined, no precipitation

6.4.3 Group 7: Value unknown

This group of flags is assigned by the DO when the exact numerical value is unknown, but significant additional information is available. This situation exists when a measurement is below the detection limit of the instrument or method, or is considered to be less accurate than normal.

For many data users it is important to know that the value is low, even if a numerical value is not available. Some users may also need to use or create a substitution value. The substitution value may be based on the detection limit (if reported), or on some other estimate. Statisticians have described methods for using the distribution function of all reported values to estimate the average of the values that fall below the detection limit.

Flag Mnemonic	V/I	Description
799 MUE	I	Measurement missing (unspecified reason), data element contains estimated value
784 LPE	I	Low precipitation, concentration estimated
783 LPU	I	Low precipitation, concentration unknown
781 BDL	V	Value below detection limit, data element contains detection limit
780 BDE	V	Value below detection limit, data element contains estimated value.
771 ARL	V	Value above range, data element contains upper range limit
770 ARE	V	Value above range, data element contains estimated value
750 ALK	I	H+ not measured in alkaline sample
701 LAU	I	Less accurate than usual, unspecified reason. (Used only with old data, for new data see groups 6 and 5)

6.4.4 Group 6: Mechanical problem

This group of flags is assigned by the DO when a measurement value is less accurate than normal due to severe weather or instrument malfunction. The measured value is reported, but should be excluded from use when strict quality control is required.

Flag Mnemonic	V/I	Description
699 LMU	I	Mechanical problem, unspecified reason
679 LUM	V	Unspecified meteorological condition
678 LHU	V	Hurricane
677 LAI	I	Icing or hoar frost in the intake
659 LSA	I	Unspecified sampling anomaly

658 LSV	I	Too small air volume
657 LPO	V	Precipitation collector overflow. Heavy rain shower (squall)
656 LWB	V	Wet-only collector failure, operated as bulk collector
655 LMI	V	Two samples mixed due to late servicing of sampler. Estimated value created by averaging
654 LLS	V	Sampling period longer than normal, observed values reported
653 LSH	V	Sampling period shorter than normal, observed values reported
649 LTP	V	Temporary power fail has affected sampler operation

6.4.5 Group 5: Chemical problem

This group of flags is assigned by the DO when a measurement value is less accurate than normal due to some kind of chemical contamination of the sample. The measured value is reported, but should be excluded from use when strict quality control is required.

Flag Mnemonic	V/I	Description
599 LUC	I	Unspecified contamination or local influence
593 LNC	I	Industrial contamination
591 LAC	I	Agricultural contamination
578 LSS	I	Large sea salt contribution (ratio between marine and excess sulphate is larger than 2.0). Used for old data only. For newer data use 451/450.
568 LSC	I	Calcium invalid due to sand contamination
567 LIC	I	pH, NH ₄ and K invalid due to insect contamination
566 LBC	I	pH, NH ₄ and K invalid due to bird droppings
565 LPC	I	K invalid due to pollen and/or leaf contamination
558 SCV	V	Sand contamination, but considered valid
557 LIV	V	Insect contamination, but considered valid
556 LBV	V	Bird droppings, but considered valid
555 LPV	V	Pollen and/or leaf contamination, but considered valid
549 LCH	I	Impure chemicals
540 LSI	I	Spectral interference in laboratory analysis
532 LHB	V	Data less accurate than normal due to high field blank value
531 LLR	V	Low recovery, analysis inaccurate
521 LBA	V	Bactericide was added to sample for storage under warm climate. Considered valid

6.4.6 Group 4: Extreme or inconsistent values

This group of flags is assigned by the DO after evaluation of the credibility of the measured values. If a measured value is extremely high or low, it may in many cases be suspected to be wrong based on statistics alone. In a conservative presentation of the data set such elements should be excluded.

Some measurements are found to be inconsistent with other measurements or with computed parameters (ion balance, conductivity, etc.). As above, such measurements may be used with caution, but should be excluded from use when strict quality control is required.

Flag Mnemonic	V/I	Description
499 INU	V	Inconsistent with another unspecified measurement
478 IBA	I	Invalid due to inconsistency discovered through ion balance calculations

477 ICO	I	Invalid due to inconsistency between measured and estimated conductivity
476 IBV	V	Inconsistency discovered through ion balance calculations, but considered valid
475 COV	V	Inconsistency between measured and estimated conductivity, but considered valid
460 ISC	I	Contamination suspected
459 EUE	I	Extreme value, unspecified error
458 EXH	V	Extremely high value, outside four times standard deviation in a lognormal distribution
457 EXL	V	Extremely low value, outside four times standard deviation in a lognormal distribution
456 IDO	I	Invalidated by data originator
451 SSI	I	Invalid due to large sea salt contribution
450 SSV	V	Considerable sea salt contribution, but considered valid

6.4.7 Group 3

This group of flags (flags 301-399) is presently not defined.

6.4.8 Group 2: Exception flags assigned by the database co-ordinator

This group of flags is reserved for use by the database co-ordinator. The flags in this group are identical to group 4 above. They are only assigned by the database co-ordinator if an inconsistency is found, and the data originator has not previously flagged the condition.

Flag Mnemonic	V/I	Description
299 CNU	V	Inconsistent with another unspecified measurement
278 CBA	I	Invalid due to inconsistency discovered through ion balance calculations
277 CCO	I	Invalid due to inconsistency between measured and estimated conductivity
276 CIV	V	Inconsistency discovered through ion balance calculations, but considered valid
275 CCV	V	Inconsistency between measured and estimated conductivity, but considered valid
260 CSC	I	Contamination suspected
259 CUE	I	Unspecified error expected
258 CXH	V	Extremely high value, outside four times standard deviation in a log-normal distribution
257 CXL	V	Extremely low value, outside four times standard deviation in a log-normal distribution
251 CSI	I	Invalid due to large sea salt contribution
250 CSV	V	Considerable sea salt contribution, but considered valid
249 QDT	V	Apparent typing error corrected. Valid measurement
211 QDI	V	Irregular data checked and accepted by database co-ordinator. Valid measurement
210 QDE	V	Episode data checked and accepted by database co-ordinator. Valid measurement

6.4.9 Group 1: Exception flags for accepted, irregular data

Flag Mnemonic	V/I	Description
147 QOD	V	Below theoretical detection limit or formal Q/A limit, but a value has been measured and reported and is considered valid
120 QOR	V	Sample reanalysed with similar results. Valid measurement
111 QOI	V	Irregular data checked and accepted by data originator. Valid measurement
110 QOE	V	Episode data checked and accepted by data originator. Valid measurement
100 QOU	V	Checked by data originator. Valid measurement

6.4.10 Group 0

This group of flags (flags 001-099) is presently not defined. The “flag” value 0 is not an error condition flag. It must be assigned to the flag variable for all measurements that are of normal quality. In this manner the DO confirm that the data element is valid (with no known exception that should have been flagged).

6.5 Data reporting

A new relational data base contains the concentrations or measurements with remarks/flags to the data, and the information about sites, instruments etc.

Data reporting forms have been worked out by the CCC in the past; three forms may be used for the reporting of concentrations, one for air, one for precipitation, one for air and precipitation components. Forms containing information about the sites were worked out in the past, and new less comprehensive will be worked out and distributed in 1996 together with information about the data reporting formats above.

The data reporting to be introduced in 1995 follows the NASA/AMES type 1001. Besides this format the ISO 7168 is still valid. Magnetic tapes should not be used. For users of NASA/AMES and ISO 7168 a data base will be created at NILU's external computer, and the users may transfer data directly into this data base using internet.

Data should be submitted to the CCC twice every year, in September data from January to June, and in March data from July to December. Data which are not received before the end of the following year may be excluded from the annual data reports from the CCC, due to the time-consuming calculations and long production time.

The procedure for submission of data are found in more detailed on CCC's homepage: <http://www.nilu.no/projects/ccc/submission.html>

Data are available from the CCC homepage <http://www.nilu.no/projects/ccc/emepdata.html>. Besides this annual and seasonal summaries are worked out and printed in reports.

Experience shows that errors are discovered even in the final data. When errors are discovered they are corrected as far as possible. The most correct data will therefore at any time be the data in the data base at the CCC. *New copies of this data should always be requested from the CCC for scientific use.*

6.6 References

- Chemical Rubber Co. (1985) Handbook of chemistry and physics. 66th Edition, 1985–1986. Boca Raton, CRC Press.
- Conover, W.J. (1980) Practical nonparametric statistics. New York, Wiley.
- Gilbert, R.O. (1987) Statistical methods for environmental pollution monitoring. New York, Van Nostrand Reinhold.
- Krognes, T., Gunstrøm, T.Ø. and Schaug, J. (1995) Air quality databases at NILU. EBAS version 1.01. Kjeller (NILU TR 3/95).
- Schaug, J. (1988) Quality assurance plan for EMEP. Lillestrøm, Norwegian Institute for Air Research (EMEP/CCC-Report 1/88).
- Siegel, S. (1956) Nonparametric statistics for the behavioral sciences. New York, McCraw-Hill.
- Sverdrup, H.U., Johnson, M.W. and Fleming, R.H. (1942) The oceans, their physics, chemistry, and general biology. New York, Prentice-Hall.
- Topol, L.E., Lev-On, M., Flanagan, J., Schwall, R.J., Jackson, A.E. and Mitchell, W.J. (1985) Quality assurance manual for precipitation measurement systems. Research Triangle Park, NC., U.S. Environmental Protection Agency.
- WMO (undated) Chemical analysis of precipitation for GAW: Laboratory analytical methods and sample collection standards. Geneva (WMO/GAW No. 85). (WMO/TD-550).