

FOREST INVENTORY: SÃO FÉLIX DO XINGU

SFX_A03_2012_INVENTORY

1.0 GENERAL INFORMATION

The Forest Inventory São Félix do Xingu (SFX_A03_2012_INVENTORY) is located in Pará State, Brazil. A total of 8 40x40m plots were measured. Trees with diameter at breast height (DBH) equal to or greater than 10cm were accounted for and measured within the plot area (see Fig. 1).

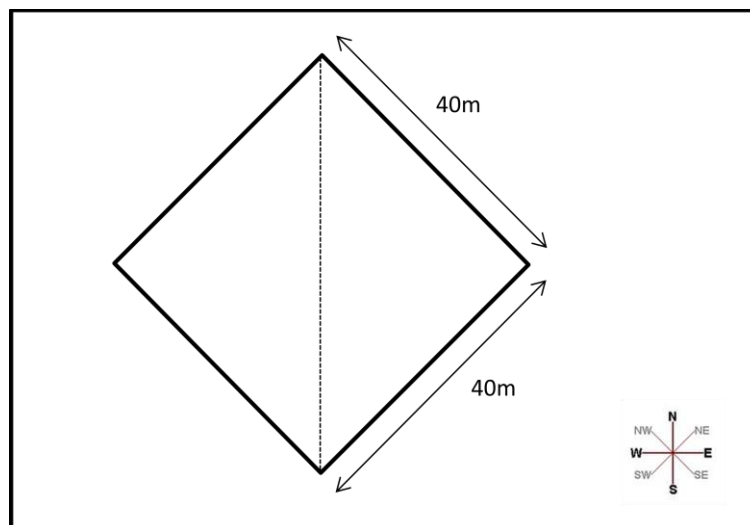

FIG 1. REPRESENTATION OF THE 40 X 40M PLOT, THE DOTTED LINE DEPICTS THE PLOT CENTER LINE.

2.0 INVENTORY DATA RECORDED - .CSV FILE CONTENT

For each tree the following measurements were recorded/calculated:

area: A code name given to the area.

plot: the plot number.

tree: tree number

common_name: tree common name.

scientific_name: tree scientific name.

family_name: tree family name

WSD (g/cm³):

If tree is alive:

wood specific gravity - oven-dry wood over green volume (Chave et al, 2009¹).

If tree is dead (standing dead):

Dead trees are divided into 5 decay classes (Keller et al, 2004²),

DBH (cm): Diameter at breast height, 1.3 m above the ground.

BA(m²): individual basal area.

AGB(Mg): individual Above Ground Biomass

If tree is alive: $AGB \text{ (Mg)} = 0.0509 * WSD * DBH^2 * H_{tot}$ (Chave, 2005³)

If tree is dead (standing dead): $AGB \text{ (Mg)} = \text{Necromass volume (Palace, 2007⁴)} * WSD$

If palm(alive or dead): $AGB \text{ (Mg)} = \{\exp[0.9285 \ln(DBH^2) + 5.7236]1.05001\} / 10^3$ (Nascimento and Laurence, 2002⁵)

If liana(alive or dead): $AGB \text{ (Mg)} = \exp[-1.484 + 2.657 \ln(D)]$ (Schnitzer et al, 2006⁶)

type(class) Divided into four classes:

Liana (L): woody vines, inclusion was based on the position of the vine at 1.3 m above the ground, not the rooting position.

Palms (P): leafed palms, inclusion based on the diameter at the ground surface. Litter was removed from around the base for measurement.

Trunked palms (Pt): palms with a trunk measurable at 1.3 m

Other (O): Trees

dead: Standing dead.

D: tree is dead

A: tree is alive

D_class: Decomposition Class (Keller et al, 2004²)

Hcom: Commercial Height (m), measured using a clinometer and tape as the height of the lowest leaf (bottom of the canopy)

Htot: Total Height (m), measured using a clinometer and tape as the height to the highest point of the tree crown.

RN (m): Radius to the north of the tree crown.

RS (m): Radius to the south of the tree crown.

RE (m): Radius to the east of the tree crown.

RW (m): Radius to the west of the tree crown.

Date (ISO 8601): date

UTM_Easting: X coordinate of tree individual location calculated based on measurements of tree X position with respect to the transect.

UTM_Northing: Y coordinate of tree individual location calculated based on measurements of tree Y position with respect to the transect.

3.0 COMPLEMENTARY INFORMATION

NA = not available/not applicable

NI = not identified

4.0 REFERENCES

³Chave, J., Andalo, C., Brown, S., Cairns, M. A., Chambers, J. Q., Eamus, D., Folster, H., Fromard, F., Higuchi, N., Kira, T., Lescure, J.-P., Nelson, B. W., Ogawa, H., Puig, H., Riera B. & Yamakura, T. (2005) Tree allometry and improved estimation of carbon stocks and balance in tropical forests. *Oecologia* 145: 87–99.

¹Chave, J., Coomes, D., Jansen, S., Lewis, L.S., Swenson, N. & Zanne, A. (2009) Towards a worldwide wood economics spectrum. *Ecology Letters*, 12, 351–366.

²Keller, M., Palace, M., Asner, G.P., Pereira, R. & Silva, J.N.M.(2004) Coarse woody debris in undisturbed and logged forests in the eastern Brazilian Amazon. *Global Change Biol.* 10 (5), 784–795.

⁵Nascimento, H.E.M. & Laurance, F.W. (2002) Total aboveground biomass in central Amazonian rainforests: a landscape-scale study. *Forest Ecology and Management* 168 (2002) 311–321.

⁴Palace, M., Keller M., Asner, G.P., Silva, J.N.M., Passos C. (2007) Necromass in undisturbed and logged forests in the Brazilian Amazon. *Forest Ecology and Management* 238 (2007) 309–318.

⁶Schnitzer, S.A. DeWalt, S.J., Chave, J. (2006) Censusing and Measuring Lianas: A Quantitative Comparison of the Common Methods. *Biotropica* 38:5,581-591.